

Union County, NC

Union County Government Center
500 North Main Street
Monroe, North Carolina



Meeting Agenda

Monday, May 4, 2026

6:00 PM

Board Room, First Floor

Board of Commissioners

Chair Brian Helms
Vice Chair Christina Helms
Commissioner Clancy Baucom
Commissioner Melissa Merrell

Closed Session - 5:15 PM

26-256

Closed Session

INFORMATION CONTACT:

Lynn G. West, Clerk to the Board of Commissioners, 704-283-3853

ACTION REQUESTED:

Enter into Closed Session pursuant to NCGS 143-318.11.

PRIOR BOARD ACTIONS:

None.

BACKGROUND:

Enter into Closed Session for the following purpose(s):

1) pursuant to G.S. 143-318.11(a)(1), to prevent the disclosure of information that is privileged or confidential pursuant to G.S. 153A-98; and

2) pursuant to G.S. 143-318.11(a)(3), to consult with an attorney in order to preserve the attorney-client privilege; and

3) pursuant to G.S. 143-318.11(a)(6), to consider the qualifications, competence, performance, character, fitness, conditions of appointment, or conditions of initial employment of an individual public officer or employee or prospective public officer or employee; or to hear or investigate a complaint, charge, or grievance by or against an individual public officer or employee.

FINANCIAL IMPACT:

None.

Opening of Meeting - 6:00 PM

Invocation - Chair Brian Helms

Pledge of Allegiance

26-257

Consideration of Appointment to Fill the Vacancy in the Membership of the Union County Board of Commissioners

INFORMATION CONTACT:

Brian Helms, Board of County Commissioners, Chair

ACTION REQUESTED:

Consider Appointment to Fill the Vacancy in the Membership of the Union County Board of Commissioners.

PRIOR BOARD ACTIONS:

None.

BACKGROUND:

A vacancy occurred in the membership of the Union County Board of Commissioners on March 31, 2026, due to the resignation of Mr. Gary Sides. Pursuant to N.C.G.S. §

153A-27, the Board has 60 days after the day the vacancy occurs to fill the position. To be eligible for appointment to the position, a person must be a member of the same political party as Mr. Sides (Republican Party).

N.C.G.S. § 153A-27 provides that the Board of Commissioners shall consult with the county executive committee of the appropriate political party before filling a vacancy and receiving its recommendation. To fulfill this requirement, the Union County Republican Party met on Thursday, April 16, 2026, to provide that recommendation.

FINANCIAL IMPACT:

None.

Informal Comments

Public Hearing(s)

Staff Recognition

[26-173](#)

Recognition of the 2026 Miss Union County Pageant Winners

INFORMATION CONTACT:

Brian Matthews, County Manager, 704-283-3636

ACTION REQUESTED:

Recognize 2026 Miss Union County Pageant Winners

PRIOR BOARD ACTIONS:

None

BACKGROUND:

The 2026 Miss Union County Pageant was held on Saturday, April 18, 2026, at the Union County Ag Center.

Terry Connell-Davis, Miss Union County Pageant Director, will be present to introduce the winners in the following age divisions:

Miss Union County 2026 - Camryn Tuttle

Elite Teen Miss Union County - Devangi Prasannan

Teen Miss Union County - Presley SanFilippo

Pre-Teen Miss Union County and Community Service Queen - Kinsley Mullis

Young Miss Union County - Haven Grace Sutton

Little Miss Union County - Rylee Polk

Petite Miss Union County - Rosabelle Roberts

Toddler Miss Union County - Rylinn Skye Sutton

Baby Miss Union County - Azalea Lockhart

FINANCIAL IMPACT:

None

[26-248](#)

Recognize Lifesaver Award Recipients

INFORMATION CONTACT:

Patrick Niland, County Manager's Office, Deputy County Manager,
704-283-3630

ACTION REQUESTED:

Recognize Public Health Nurses Maegan Trull and Jennifer Gribben for their lifesaving actions while working at the emergency shelter during Winter Storm Fern.

PRIOR BOARD ACTIONS:

None.

BACKGROUND:

On Jan. 25, 2026, while staffing the County's emergency shelter during Winter Storm Fern, nurses Maegan Trull and Jennifer Gribben demonstrated exceptional clinical skill, professionalism and composure when a shelter client experienced a life-threatening medical crisis. While conducting a routine intake assessment, the nurses quickly identified that the client's condition was rapidly declining. The individual became unresponsive and had shallow, irregular breathing. Without hesitation, Trull and Gribben transitioned from assessment to lifesaving care. They safely assisted the individual to the floor, ensured the airway was open, and immediately began appropriate resuscitative measures. Their rapid recognition of the situation, paired with decisive action and seamless teamwork, ensured that critical care was delivered without delay.

The County's Management Team surprised Trull and Gribben with the Lifesaver Award on April 10. The Lifesaver Award is presented to County employees whose actions directly contribute to saving a life.

FINANCIAL IMPACT:

None.

26-249

Recognize Public Communications Team for Earning Numerous State Awards

INFORMATION CONTACT:

Clayton Voignier, County Manager's Office, Assistant County Manager,
704-283-3687

ACTION REQUESTED:

Recognize Public Communications Director Liz Cooper for being named North Carolina Communicator of the Year by the North Carolina City & County Communicators (NC3C) and the Public Communications team for earning four Excellence in Communications Awards.

PRIOR BOARD ACTIONS:

None.

BACKGROUND:

Union County Public Communications Director Liz Cooper has been named **North Carolina Communicator of the Year** by North Carolina City & County Communicators (NC3C), one of the organization's highest individual honors. The prestigious award recognizes an individual who has demonstrated exceptional skill, creativity and impact in government communications over the past year. Cooper is one of only two

professionals statewide to receive an individual award from NC3C in 2026.

In addition to this individual recognition, Union County's Public Communications team earned **four Excellence in Communications Awards** as part of the NC3C annual awards program recognizing exemplary communications work. Union County was among a record 39 North Carolina jurisdictions recognized this year.

Award-winning projects include:

- **First Place - Branding/Logo:** Union County Economic Development logo
- **Second Place - Multi-Platform Campaign:** "Foster the Future" Foster Parent Recruitment Campaign (in partnership with Social Services)
- **Third Place - Special Programming - Video:** *Women in Leadership: Honoring Our County Commissioners* (Women's History Month video)
- **Third Place - Crisis Communications:** Coordinated response following the Unionville tornado in March 2025

Union County's Public Communications department serves both residents and employees by delivering timely, accurate and impactful information across multiple channels. The team manages organizational communications strategy, media relations, digital content, branding, marketing, public records coordination, audiovisual support, event planning, and more.

FINANCIAL IMPACT:

None.

Consent Agenda

[26-240](#)

Resolution Regarding Abandonment of NCDOT Road Maintenance for a Portion of North Main Street in Wingate

INFORMATION CONTACT:

Lee Jenson, Planning, Director, 704-283-3564

ACTION REQUESTED:

Adopt resolution approving proposed abandonment of maintenance.

BACKGROUND:

The NCDOT requests that Union County adopt a resolution in support of abandoning a portion of North Main Street between Wilson Street and McIntyre Road in Wingate in order for the Town of Wingate to begin maintaining that same portion of N. Main St.

FINANCIAL IMPACT:

None.

[26-235](#)

Appointments to the Transportation Advisory Board

INFORMATION CONTACT:

Theresa Torres, Human Services Agency, Transportation Director,
704-283-3598

ACTION REQUESTED:

Appoint recommended representatives to the Union County
Transportation Advisory Board.

PRIOR BOARD ACTIONS:

None.

BACKGROUND:

The North Carolina Department of Transportation (NCDOT) requires that all Transit Systems have an Advisory Board in place comprised of stakeholders from the service area who have an interest in the services being provided by the Transit Systems. The Transportation Advisory Board (TAB) serves as a steering committee and is expected to discuss unmet needs in the service area, service design, billing rates and fares, and to offer assistance in resolving customer complaints. The Board must include representatives from the elderly, minority, limited English proficiency, disabled and/or low-income populations, or include individuals that represent these consumer groups and are able to encourage the transit system to be more sensitive to the needs of these diverse groups when necessary. The TAB is required to meet at a minimum on a quarterly basis as one means of seeking public involvement. Guidance from NCDOT recommends that the TAB have between 11-17 members. Union County currently has 13 positions filled. The following individuals have indicated an interest in serving and were unanimously approved by the TAB.

1. Kimberly Jordan
2. Nicole Myers
3. Rasheen Rorie
4. Aleshia Holland

FINANCIAL IMPACT:

None.

26-239

Amendment to the Library Board of Trustees Bylaws

INFORMATION CONTACT:

Nina Chaffin, Library, Director, 704-283-3561

ACTION REQUESTED:

Approve the amendment to Article VII, Paragraph 1 of the Union County Library Board of Trustees bylaws to reduce the required number of meetings from ten (10) per year to six (6) per year.

PRIOR BOARD ACTIONS:

None.

BACKGROUND:

At its regular meeting on March 17, 2026, the Union County Library Board of Trustees discussed the current frequency of its regularly scheduled meetings. During this discussion, members noted that several meetings throughout the year did not include actionable items requiring Board

consideration, prompting concerns about the efficient use of time and resources.

As a result, the Library Board considered amending its bylaws to better align meeting frequency with operational needs. The Library Board of Trustees unanimously approved a revision to Article VII, Paragraph 1, reducing the number of required meetings from ten (10) per year to six (6) per year, to be held on a bi-monthly basis.

Because the Board of County Commissioners maintains oversight authority of the Library Board of Trustees, this proposed bylaw amendment is being presented for the Commissioners' review and approval.

FINANCIAL IMPACT:

None.

26-157

Budget Amendment - Health Care Fund

INFORMATION CONTACT:

Jason May, Budget & Grants Management, Director, 704-283-3760

ACTION REQUESTED:

Approve Budget Amendment # 21.

PRIOR BOARD ACTIONS:

None.

BACKGROUND:

Union County maintains a self-insured Health Care Fund to account for employee health insurance claims and related costs. During FY 2025, claims activity exceeded budgeted projections, requiring the Health Care Fund to draw on its fund balance reserves to cover the shortfall. This amendment is necessary to restore the Health Care Fund's financial position and ensure adequate reserves are available to support ongoing claims obligations.

This amendment appropriates \$5,000,000 from General Fund unassigned fund balance and \$2,500,000 in lapsed salary savings, for a total transfer of \$7,500,000 to the Health Care Fund. The lapsed salary funds represent personnel vacancy savings realized across County departments during FY 2026. Together, these sources allow the County to replenish the Health Care Fund's fund balance without impacting current service delivery or operational budgets.

FINANCIAL IMPACT:

The Unassigned Fund Balance will decrease by \$5 million. Salaries and benefit lines from general fund department will be reduced by \$2.5 million. The Health Care Fund will be increased by \$7.5 million.

26-234

Bid Award and Construction Contract - Detention Center Walk-in Freezer and Cooler Replacement

INFORMATION CONTACT:

Linda Whitaker, Facilities and Fleet Management, Assistant Director
Design and Construction, 704-420-2626

ACTION REQUESTED:

1) Award construction contract to Garmon Mechanical Service, Inc. in the amount of \$159,392.10; 2) authorize the County Manager to, i) negotiate and execute an agreement with Garmon Mechanical Service, Inc. substantially consistent with this agenda item, ii) exercise any renewal or extension term options set forth in the agreement, and iii) terminate the agreement if deemed in the best interest of Union County, each in the County Manager's discretion; and 3) adopt Resolution Providing Notice of Construction of the Detention Center Walk-in Freezer and Cooler Replacement project.

PRIOR BOARD ACTIONS:

None.

BACKGROUND:

The existing walk-in freezer and cooler serving the detention center are at the end of their service life. The project consists of the complete removal of the existing walk-in freezer and cooler units and the installation of new insulated wall and ceiling panels, insulated walk-freezer and cooler doors and a new refrigeration system to better serve the detention center.

On January 26, 2026, Procurement and Contract Management partnered with Facilities and Fleet Management to issue an Invitation for Bid IFB 2026-051 Detention Center Walk-in Freezer and Cooler and Replacement. On March 10, 2026, two (2) bids were received. Because less than three (3) bids were received, the bids remained sealed and returned to the bidders. On March 10, 2026, IFB 2026-051 was issued to rebid the project. On March 25, 2026, (3) bids were received for the titled project. All bids were tabulated, reviewed and certified by Facilities and Fleet Management. The bids ranged from \$159,392.10 - \$287,888.34. Staff recommend the project be awarded to the lowest, responsive, responsible bidder, Garmon Mechanical Service, Inc., in the amount of \$159,392.10.

FINANCIAL IMPACT:

Funding is available within the adopted capital account Union County Jail Block Renovations, 40080112, to support the construction contract amount of \$159,392.10.

26-195

Capital Project Ordinance Amendments to Reduce Arbitrage Rebates

INFORMATION CONTACT:

Beverly Liles, Finance, Director, 704-283-3675

ACTION REQUESTED:

1) Adopt Capital Project Ordinance Amendments 211A, 239B, 254A, 273B, 277B, 283C, 284D, 288J, 301D, 305A, 343B, 347E, 349D, 350B, 367D, 369B, 380A, 386A, 388A; and 2) authorize the Finance Director

and/or County Manager to appropriate bond proceed investment income to pay arbitrage rebate liabilities to the IRS and transfer any excess investment earnings on bond proceeds not needed for arbitrage rebate payments accumulated in capital projects to the debt service funds to be spent on interest payments due.

PRIOR BOARD ACTIONS:

Capital Project Ordinances were previously approved by the BOCC at various times for projects funded from the 2019C and 2022 General Obligation Bond Issuances.

BACKGROUND:

Arbitrage in tax-exempt bonds is the profit earned by investing proceeds from tax-exempt bonds into higher-yielding taxable investments compared to the interest rate being paid on the bonds debt service payments. Because this exploits the lower interest rates allowed by tax-exempt status, bond issuers must generally rebate these excess earnings back to the IRS. This regulation prevents governments from over-issuing debt just for profit.

Unspent tax-exempt bond proceeds are subject to IRS tax exempt bond arbitrage rebate calculations on an annual basis until all bond proceeds have been spent in full. To mitigate the continuation of annual arbitrage rebate calculations and to reduce any payments due to the IRS the Finance Director is recommending replacing the funding sources on expenditures already paid on projects with the same function as the originally adopted projects to progress the spenddown of bond proceeds in a timelier fashion.

The capital project ordinances will swap funding sources, correct funding sources or close out unneeded funds on the following projects:

Public Safety; Radio Towers, Bi-Directional Antennas at UCPS, E911 TDMA P25, Sheriff's Office Administration Building;

Library; Southwest Regional Library;

General Government; Board of Elections Renovation, UC Jail Block Renovations, UC Jail Land Purchase, Historic Courthouse House Renovations Phase 1 and 2, Government Center Building Repairs, Government Center Electrical Infrastructure, Government County Facility Repairs, and UC Progress Building;

Parks and Recreation; Paving, JHP Park Amenities, JHP Lighting, Cane Creek and P&R R&R;

Community College; SPCC Campus Improvements, SPCC Camera, SPCC Technology, and SPCC Access Controls.

FINANCIAL IMPACT:

No change in funding. The rebate payments due back to the IRS are paid for through investment earnings on the bond proceeds in the bond construction bank accounts. No county dollars are required to cover the rebate payments due to the IRS. This action has the potential to reduce increased arbitrage rebates overtime.

26-224**Juvenile Crime Prevention Council (JCPC) Discretionary Funding Award****INFORMATION CONTACT:**

Beverly Liles, Finance, Director, 704-283-3675

ACTION REQUESTED:

1) Approve discretionary awards for FY 2025-2026, 2) authorize the Finance Director to approve an updated funding plan, grant agreements and documents related to these additional funds during their terms, and 3) approve Budget Amendment #22.

PRIOR BOARD ACTIONS:

None.

BACKGROUND:

JCPC is a Board appointed by Commissioners, as defined by State Statutes. JCPC provides funding and monitors Community Based alternatives to juvenile incarceration and provides funding for substance abuse prevention strategies and programs.

Funding for JCPC programs is generally adopted in the State Budget and assigned to County programs by a formula grant.

The JCPC budget is normally approved as a "pass through" line item in the County budget, meaning that the amount approved by the State is received by the County and then used for the JCPC program.

Union County has not approved JCPC programs in line-item detail in the past; rather, the JCPC Board normally negotiates, approves, and monitors line-item detail within the amount of funds allocated to the program, and provides a recommended budget to Commissioners.

JCPC has been awarded discretionary funding for the Transforming Youth program for \$2,450 to use for the remainder of FY 2026.

FINANCIAL IMPACT:

No county funding is required. Any local match will be provided by the Transforming Youth JCPC Program.

26-232**March 2026 NCVTS Motor Vehicle Tax Report****INFORMATION CONTACT:**

Vann Harrell, Tax Administration, Tax Administrator, 704-283-3748;
Kristen Foxworth, Tax Administration, Deputy Tax Administrator,
704-283-3591

ACTION REQUESTED:

Approve the March 2026 NCVTS Motor Vehicle Tax Refund Report.

PRIOR BOARD ACTIONS:

None.

BACKGROUND:

The refunds included in this report represent adjustments made to tax bills that resulted in refunds of motor vehicle taxes paid under the Tax and Tag Together program operated jointly between the counties and the state.

FINANCIAL IMPACT:

\$895.16

26-254**Compensation Adjustment for the Sheriff****INFORMATION CONTACT:**

Julie Broome, Human Resources, Director, 704-283-3869

ACTION REQUESTED:

Authorize the County Manager to take such action as necessary to provide an increase in compensation of \$5,375 to the Sheriff, retroactive to January 1, 2026.

BACKGROUND:

Pursuant to G.S.153A-92(a), the Board of Commissioners shall fix or approve the schedule of pay, expense allowance and other compensation of all county officers and employees, whether elected or appointed. Any increase in the compensation of elected officials (Sheriff) is done so at the discretion of the Board of Commissioners.

FINANCIAL IMPACT:

No additional funding required. Sufficient funding is included in the FY26 budget.

26-255**Compensation Adjustment for the Register of Deeds****INFORMATION CONTACT:**

Julie Broome, Human Resources, Director, 704-283-3869

ACTION REQUESTED:

Authorize the County Manager to take such action as necessary to provide an increase in compensation of \$10,220 to the Register of Deeds, retroactive to January 1, 2026.

BACKGROUND:

Pursuant to G.S.153A-92(a), the Board of Commissioners shall fix or approve the schedule of pay, expense allowance and other compensation of all county officers and employees, whether elected or appointed. Any increase in the compensation of elected officials (Register of Deeds) is done so at the discretion of the Board of Commissioners.

FINANCIAL IMPACT:

No additional funding required. Sufficient funding is included in the FY26 budget.

[26-250](#)**Resolution - Amend the Board of Commissioners' 2026 Regular Meeting Schedule****INFORMATION CONTACT:**

Lynn G. West, Clerk to the Board, 704-283-3853

ACTION REQUESTED:

Adopt the Resolution Amending the Regular Meeting Schedule of the Union County Board of Commissioners for 2026

PRIOR BOARD ACTIONS:

December 8, 2025, Regular Meeting, Agenda Item #25-750 - Adopted the Resolution for the Regular Meeting Schedule of the Union County Board of Commissioners for 2026

BACKGROUND:

On December 8, 2025, the Board of Commissioners adopted its regular meeting schedule for 2026. This resolution amends the previously adopted regular meeting schedule by removing the Monday, June 15, 2026, regular meeting and replacing it with a regular meeting scheduled for the next day, Tuesday, June 16, 2026. The revised regular meeting schedule is shown on Attachment "A" to this Resolution.

FINANCIAL IMPACT:

None.

[26-263](#)**Resolution - Opioid Settlement Funding Plan (FY2027-FY2030)****INFORMATION CONTACT:**

Patrick Niland, County Manager's Office, Deputy County Manager, 704-283-3630

ACTION REQUESTED:

1) Adopt the Resolution to Direct the Expenditure of Opioid Settlement Funds for FY2027-FY2030; and 2) authorize the County Manager to negotiate and execute agreements and related documents consistent with this agenda item.

PRIOR BOARD ACTIONS:

June 19, 2023, Regular Meeting, Agenda Item # 23-367 - Board approval of the first phase of opioid settlement funding.

BACKGROUND:

North Carolina participated in the national opioid settlements, and the North Carolina Association of County Commissioners (NCACC) and the North Carolina Department of Justice (NCDOJ) partnered to help ensure settlement proceeds are distributed to local jurisdictions for programs and services that directly benefit individuals and communities most impacted by the opioid epidemic.

Union County entered into Memorandums of Agreement (MOAs) with the State of North Carolina governing both the amount of settlement funding to be received and the allowable uses of those funds. These agreements also establish the framework for how North Carolina and participating local governments will use proceeds from future national settlements or

bankruptcy resolutions involving opioid manufacturers, distributors, and related entities.

Union County is projected to receive approximately \$19.9 million in opioid settlement proceeds over an 18-year period. Under the terms of the MOAs, local governments are required to engage in a collaborative planning process to determine how these funds will be invested.

To meet this requirement, County staff convened community stakeholders beginning in September 2025 and facilitated a four-month strategic planning process to develop recommendations for the FY2027-FY2030 funding period. Those recommendations were presented to and endorsed by the Board of Commissioners at its April 20, 2026, Regular Meeting.

The attached resolution directs the expenditure of opioid settlement funds in accordance with that approved funding plan and authorizes the County Manager to implement the plan through agreements with selected providers and partners.

FINANCIAL IMPACT:

\$7,020,950.39 in opioid settlement funds is proposed for allocation under the FY2027-FY2030 funding plan.

Information Only

26-211

Tax Collector's Departmental Report for March 2026

INFORMATION CONTACT:

Kristen Foxworth, Tax Administration, Deputy Tax Administrator,
704-283-3591

ACTION REQUESTED:

None - Information Only.

PRIOR BOARD ACTIONS:

None.

BACKGROUND:

This report reflects the totals of all tax transactions within the Tax Collector's Office for the month of March 2026 as required by NCGS 105-350(7).

FINANCIAL IMPACT:

None.

26-231

Tax Refunds, Releases and Prorations Approved by Finance Officer

INFORMATION CONTACT:

Beverly Liles, Finance, Director, 704-283-3675

ACTION REQUESTED:

None - Information Only.

PRIOR BOARD ACTIONS:

None.

BACKGROUND:

On September 8, 2020, the Board of Commissioners adopted a Resolution Delegating Authority for Tax Releases and Refunds of less than \$100 to Union County's Finance Officer. The resolution and NC GS 105-381(b) require such refunds to be reported to the Board regarding actions taken on requests for releases or refunds. All such actions shall be recorded in the Board's minutes. NC GS 105-330.6 authorizes the tax collector to direct an order for a tax refund of prorated taxes to the county finance officer related to surrendering of registered motor vehicle plates. The finance officer shall issue a refund to the vehicle owner. The attached report is for March 2026 NCVTS releases and refunds less than \$100 and prorations approved by the finance officer.

FINANCIAL IMPACT:

None.

26-236

South Piedmont Regional Autopsy Center - April 2026 Quarterly Report

INFORMATION CONTACT:

Stephanie Dudley, County Manager's Office, Business Manager,
704-292-2668

ACTION REQUESTED:

None - Information Only.

PRIOR BOARD ACTIONS:

None.

BACKGROUND:

This is the quarterly progress report on the operations of the South Piedmont Regional Autopsy Center (SPRAC).

FINANCIAL IMPACT:

None.

26-243

FY2026 Budget Transfers Reporting - 3rd Quarter

INFORMATION CONTACT:

Blake Hart, Budget & Grants Management, Assistant Director,
704-283-3674

ACTION REQUESTED:

None - Information Only.

PRIOR BOARD ACTIONS:

None.

BACKGROUND:

Per sections XV, XVI, XVII, XVIII, XI, XIX, and XX of the FY 2026 Adopted Operating and Capital Budget Ordinance, management reports the following County Manager Budget Amendments (CMBA) made by the County Manager for the third quarter of fiscal year 2026.

CMBA 11: To transfer funds from the FY 2026 COLA from the central

pool for half the fiscal year for General Fund, UC Water, Solid Waste, PC & WC. Approval authority stated in Section XI of the FY 2026 Adopted Operating and Capital Budget Ordinance.

CMBA 12: To transfer funds from Human Services Community Support & Outreach to Facilities Management to correct an overpayment for Christmas Bureau rent and utilities. Approval authority stated in Section XV of the FY 2026 Adopted Operating and Capital Budget Ordinance.

CMBA 13: Recognize and appropriate revenue from the North Carolina Emergency Management (NCEM) State & Local Cybersecurity Grant Program (SLCGP) to purchase a 12-month subscription for penetration testing to identify vulnerabilities and provide clear remediation guidance. Approval authority stated in Section XVIII of the FY 2026 Adopted Operating and Capital Budget Ordinance.

FINANCIAL IMPACT:

None.

26-247

Union EMS Quarterly Financial Statements

INFORMATION CONTACT:

Beverly Liles, Finance, Director, 704-283-3675

ACTION REQUESTED:

None - Information Only.

PRIOR BOARD ACTIONS:

None.

BACKGROUND:

Union EMS is required to provide the County with quarterly unaudited financial statements in the terms of the contract agreement with Atrium Health/Union EMS.

FINANCIAL IMPACT:

None.

26-260

Wastewater Treatment Capacity - Monthly Update

INFORMATION CONTACT:

John Shutak, Union County Water, Engineering Director, 704-283-3651

ACTION REQUESTED:

None - Information Only.

PRIOR BOARD ACTIONS:

None.

BACKGROUND:

Union County Water is closely monitoring the wastewater treatment capacities at our Water Reclamation Facilities. Permitting Capacity is evaluated using the Actual Plant Flows plus the Permitted/Obligated Flows (unconnected). Union County Water was asked to provide regular updates. Plant flow information through March 2026 is summarized in the attached table.

Twelve Mile Creek

- Percent of Actual Flows = 69.7%
- Percent of Actual + Permitted Flows = 88.6%
- Actual Flows (MGD) = 5.227
- Actual + Permitted Obligated Flows (MGD) = 6.641

Crooked Creek

- Percent of Actual Flows = 63.7%
- Percent of Actual + Permitted Flows = 88.4%
- Actual Flows (MGD) = 1.211
- Actual + Permitted Obligated Flows (MGD) = 1.680

Olde Sycamore

- Percent of Actual Flows = 26.0%
- Percent of Actual + Permitted Flows = 26.0%
- Actual Flows (MGD) = 0.039
- Actual + Permitted Obligated Flows (MGD) = 0.039

Tallwood

- Percent of Actual Flows = 40.0%
- Percent of Actual + Permitted Flows = 40.0%
- Actual Flows (MGD) = 0.020
- Actual + Permitted Obligated Flows (MGD) = 0.020

Grassy Branch

- Percent of Actual Flows = 76.0%
- Percent of Actual + Permitted Flows = 78.0%
- Actual Flows (MGD) = 0.038
- Actual + Permitted Obligated Flows (MGD) = 0.039

In addition to the wastewater treatment capacities, flow volumes associated with development projects that are in the planning and review process within the Twelve Mile Creek and Crooked Creek WRF service areas are provided for information as well. Development flow volumes through March 2026 are summarized in the attached tables.

FINANCIAL IMPACT:

None.

26-261**March 2026 Union County Public Schools Monthly Report****INFORMATION CONTACT:**

Beverly Liles, Finance, Director, 704-283-3675

ACTION REQUESTED:

None - Information Only.

PRIOR BOARD ACTIONS:

None.

BACKGROUND:

This is the monthly report from UCPS as required by the Budget Ordinance.

FINANCIAL IMPACT:

None.

Business**26-252****Rezoning Petition RZ-2026-004 McAlister****INFORMATION CONTACT:**

John Wear, Planning Department, Senior Planner - Current Planning,
704-283-3605

ACTION REQUESTED:

Approve or deny proposed rezoning.

TO **APPROVE** THE PROPOSED AMENDMENT (THE PROPOSAL IS CONSISTENT WITH THE CURRENT PLAN)

Motion

- (i) Adopt the Ordinance Approving Revision to the Official Zoning Map of Union County, North Carolina, and (ii) adopt the consistency and reasonableness statement for approval.

TO **DENY** THE PROPOSED AMENDMENT (THE PROPOSAL IS INCONSISTENT WITH THE CURRENT PLAN)

Motion

- (i) Deny rezoning petition RZ-2026-004 from Tommy McAlister, Jr.; and
(ii) adopt the consistency and reasonableness statement for denial.

PRIOR BOARD ACTION:

April 20, 2026, Regular Meeting, Agenda Item #26-203 - Conduct public hearing.

BACKGROUND:

This case is a request to rezone one parcel totaling 10.848 acres appearing on the tax map as tax parcel 04-036-007 located on Pageland Highway from Highway Corridor (HC) with Conditions to Light Industrial (LI). The rezoning request is a straight rezoning, so there are no conditions associated with this request.

The Land Use Board evaluated this proposal at its March 17 meeting and recommended approval on a 7-0 vote, citing consistency with the land

use map.

A public hearing was conducted April 20, 2026, and no one spoke for or against the proposed rezoning.

FINANCIAL IMPACT:

None.

26-210

Presentation - Union County Water Capital Program Update

INFORMATION CONTACT:

John Shutak, Union County Water, Engineering Director, 704-283-3651

ACTION REQUESTED:

None.

PRIOR BOARD ACTIONS:

None.

BACKGROUND:

The Capital Improvement Program for Union County Water (UCW), as adopted by the Board of County Commissioners, includes projects related to the expansion of the water and wastewater systems, rehabilitation and replacement of existing infrastructure, as well as buildings and facilities.

UCW staff will provide a presentation on the overall status of the Capital Improvement Program with detailed information on a selection of representative projects.

FINANCIAL IMPACT:

None at this time. Direction received, if any, may impact future expenditures.

26-246

FY 2027 Capital Improvement Project Review

INFORMATION CONTACT:

Jason May, Budget & Grant Management, Director, 704-283-3760

ACTION REQUESTED:

Receive information.

PRIOR BOARD ACTIONS:

None.

BACKGROUND:

Staff will present the recommended Capital Improvement Plan (CIP) for Fiscal Year 2027, including proposed projects and funding sources. No action is required; this item is for informational purposes only.

FINANCIAL IMPACT:

None. Proposed CIP will be included in the FY 2027 Budget presentation on June 1, 2026.

26-253

FY 2027 Health Plan Changes

INFORMATION CONTACT:

Brian Matthews, County Manager, 704-292-2597

ACTION REQUESTED:

Receive information

PRIOR BOARD ACTIONS:

None

BACKGROUND:

The County Manager will present information to the Board of Commissioners about the upcoming changes to the County's Health Insurance Plan for FY 2027.

FINANCIAL IMPACT:

None

26-238**Appointment to the Consolidated Human Services Board****INFORMATION CONTACT:**

Janet Payne, Human Services Agency, Executive Director, 704-296-4348; Amy Dickey, Consolidated Human Services Board Chair

ACTION REQUESTED:

Review applications and consider appointing one of the recommended applicants for the vacant Consolidated Human Services Board "Other Person" position.

PRIOR BOARD ACTIONS:

None.

BACKGROUND:

The Consolidated Human Services Board (CHSB), pursuant to N.C. general statute § 153A-77, is permitted to be composed of up to 25 members and composition of the board shall reasonably reflect the population makeup of the County. Currently, the Union County CHSB has 19 membership positions, each of which has a specific designation. Eight positions are filled and there are 11 vacancies including:

- Consumer of Human Services (2)
- Dentist (1)
- Registered Nurse (1)
- Other Person (1)
- Pharmacist (1)
- Physician - Psychiatrist (1)
- Optometrist (1)

As is the County's usual practice, the vacancies available for appointment were advertised by posting a notice on the County's website:

<https://www.unioncountync.gov/government/boards-committees/boardsc committees>

Multiple applications were received to fill the one "Other Person" vacancy and members of the CHSB interviewed the applicants prior to the April 13, 2026 meeting and the CHSB reviewed and discussed all applications at the April 13, 2026 meeting and voted to recommend that the Board of County Commissioners consider the following individuals for appointment

to the CHSB to fill the “Other Person” vacancy:

- Mr. Ben Mount is eligible to fill the “Other Person” position.
- Mr. Michael Evola is eligible to fill the “Other Person” position.
- Ms. Linda Yang is eligible to fill the “Other Person” position.

A copy of each individual’s application is included for the Board’s review and consideration.

FINANCIAL IMPACT:

\$200 per year per member (\$20 meeting x 10 meetings a year).

26-245

Appoint Union County Board of Commissioners Representative to Vacant Position on Monroe-Union County Economic Development Commission Board of Directors

INFORMATION CONTACT:

Ron Mahle, Economic Development, Director, 980-476-5279

ACTION REQUESTED:

Appoint Union County Board of Commissioners representative to open position on the Monroe-Union County Economic Development Commission Board of Directors to run through the remainder of the current term, June 30, 2026.

PRIOR BOARD ACTIONS:

None.

BACKGROUND:

As set forth in Section 2(a) of the Interlocal Agreement between Union County and the City of Monroe establishing the Monroe-Union County Economic Development Commission, it is provided that Board members serve one-year terms, commencing on July 1 and running through June 30 of each year. Commissioner Sides was appointed (serving *ex officio*) as a BOCC-appointed EDC Board Member. In the case of a vacancy, the appointing board shall appoint a new member to serve the remainder of the unexpired term.

Due to Commissioner Sides’ resignation and unfortunate passing, the Board of County Commissioners is requested to consider appointing a person to fill his position on the EDC Board of Directors.

FINANCIAL IMPACT:

None.

County Manager's Comments

Commissioners' Comments

Adjournment



Union County, NC

Staff Report

Union County Government
Center
500 North Main Street
Monroe, North Carolina
www.unioncountync.gov

File #: 26-256

Agenda Date: 5/4/2026

TITLE:

Closed Session

INFORMATION CONTACT:

Lynn G. West, Clerk to the Board of Commissioners, 704-283-3853

ACTION REQUESTED:

Enter into Closed Session pursuant to NCGS 143-318.11.

PRIOR BOARD ACTIONS:

None.

BACKGROUND:

Enter into Closed Session for the following purpose(s):

- 1) pursuant to G.S. 143-318.11(a)(1), to prevent the disclosure of information that is privileged or confidential pursuant to G.S. 153A-98; and
- 2) pursuant to G.S. 143-318.11(a)(3), to consult with an attorney in order to preserve the attorney-client privilege; and
- 3) pursuant to G.S. 143-318.11(a)(6), to consider the qualifications, competence, performance, character, fitness, conditions of appointment, or conditions of initial employment of an individual public officer or employee or prospective public officer or employee; or to hear or investigate a complaint, charge, or grievance by or against an individual public officer or employee.

FINANCIAL IMPACT:

None.



Union County, NC

Staff Report

Union County Government
Center
500 North Main Street
Monroe, North Carolina
www.unioncountync.gov

File #: 26-257

Agenda Date: 5/4/2026

TITLE:

Consideration of Appointment to Fill the Vacancy in the Membership of the Union County Board of Commissioners

INFORMATION CONTACT:

Brian Helms, Board of County Commissioners, Chair

ACTION REQUESTED:

Consider Appointment to Fill the Vacancy in the Membership of the Union County Board of Commissioners.

PRIOR BOARD ACTIONS:

None.

BACKGROUND:

A vacancy occurred in the membership of the Union County Board of Commissioners on March 31, 2026, due to the resignation of Mr. Gary Sides. Pursuant to N.C.G.S. § 153A-27, the Board has 60 days after the day the vacancy occurs to fill the position. To be eligible for appointment to the position, a person must be a member of the same political party as Mr. Sides (Republican Party).

N.C.G.S. § 153A-27 provides that the Board of Commissioners shall consult with the county executive committee of the appropriate political party before filling a vacancy and receiving its recommendation. To fulfill this requirement, the Union County Republican Party met on Thursday, April 16, 2026, to provide that recommendation.

FINANCIAL IMPACT:

None.



Union County, NC

Staff Report

Union County Government
Center
500 North Main Street
Monroe, North Carolina
www.unioncountync.gov

File #: 26-173

Agenda Date: 5/4/2026

TITLE:

Recognition of the 2026 Miss Union County Pageant Winners

INFORMATION CONTACT:

Brian Matthews, County Manager, 704-283-3636

ACTION REQUESTED:

Recognize 2026 Miss Union County Pageant Winners

PRIOR BOARD ACTIONS:

None

BACKGROUND:

The 2026 Miss Union County Pageant was held on Saturday, April 18, 2026, at the Union County Ag Center.

Terry Connell-Davis, Miss Union County Pageant Director, will be present to introduce the winners in the following age divisions:

Miss Union County 2026 - Camryn Tuttle

Elite Teen Miss Union County - Devangi Prasannan

Teen Miss Union County - Presley SanFilippo

Pre-Teen Miss Union County and Community Service Queen - Kinsley Mullis

Young Miss Union County - Haven Grace Sutton

Little Miss Union County - Rylee Polk

Petite Miss Union County - Rosabelle Roberts

Toddler Miss Union County - Rylinn Skye Sutton

Baby Miss Union County - Azalea Lockhart

FINANCIAL IMPACT:

None



Union County, NC

Staff Report

Union County Government
Center
500 North Main Street
Monroe, North Carolina
www.unioncountync.gov

File #: 26-248

Agenda Date: 5/4/2026

TITLE:

Recognize Lifesaver Award Recipients

INFORMATION CONTACT:

Patrick Niland, County Manager's Office, Deputy County Manager, 704-283-3630

ACTION REQUESTED:

Recognize Public Health Nurses Maegan Trull and Jennifer Gribben for their lifesaving actions while working at the emergency shelter during Winter Storm Fern.

PRIOR BOARD ACTIONS:

None.

BACKGROUND:

On Jan. 25, 2026, while staffing the County's emergency shelter during Winter Storm Fern, nurses Maegan Trull and Jennifer Gribben demonstrated exceptional clinical skill, professionalism and composure when a shelter client experienced a life-threatening medical crisis. While conducting a routine intake assessment, the nurses quickly identified that the client's condition was rapidly declining. The individual became unresponsive and had shallow, irregular breathing. Without hesitation, Trull and Gribben transitioned from assessment to lifesaving care. They safely assisted the individual to the floor, ensured the airway was open, and immediately began appropriate resuscitative measures. Their rapid recognition of the situation, paired with decisive action and seamless teamwork, ensured that critical care was delivered without delay.

The County's Management Team surprised Trull and Gribben with the Lifesaver Award on April 10. The Lifesaver Award is presented to County employees whose actions directly contribute to saving a life.

FINANCIAL IMPACT:

None.



Union County, NC

Staff Report

Union County Government
Center
500 North Main Street
Monroe, North Carolina
www.unioncountync.gov

File #: 26-249

Agenda Date: 5/4/2026

TITLE:

Recognize Public Communications Team for Earning Numerous State Awards

INFORMATION CONTACT:

Clayton Voignier, County Manager's Office, Assistant County Manager, 704-283-3687

ACTION REQUESTED:

Recognize Public Communications Director Liz Cooper for being named North Carolina Communicator of the Year by the North Carolina City & County Communicators (NC3C) and the Public Communications team for earning four Excellence in Communications Awards.

PRIOR BOARD ACTIONS:

None.

BACKGROUND:

Union County Public Communications Director Liz Cooper has been named **North Carolina Communicator of the Year** by North Carolina City & County Communicators (NC3C), one of the organization's highest individual honors. The prestigious award recognizes an individual who has demonstrated exceptional skill, creativity and impact in government communications over the past year. Cooper is one of only two professionals statewide to receive an individual award from NC3C in 2026.

In addition to this individual recognition, Union County's Public Communications team earned **four Excellence in Communications Awards** as part of the NC3C annual awards program recognizing exemplary communications work. Union County was among a record 39 North Carolina jurisdictions recognized this year.

Award-winning projects include:

- **First Place - Branding/Logo:** Union County Economic Development logo
- **Second Place - Multi-Platform Campaign:** "Foster the Future" Foster Parent Recruitment Campaign (in partnership with Social Services)
- **Third Place - Special Programming - Video:** *Women in Leadership: Honoring Our County Commissioners* (Women's History Month video)
- **Third Place - Crisis Communications:** Coordinated response following the Unionville tornado in March 2025

Union County's Public Communications department serves both residents and employees by delivering timely, accurate and impactful information across multiple channels. The team manages organizational communications strategy, media relations, digital content, branding, marketing, public records coordination, audiovisual support, event planning, and more.

FINANCIAL IMPACT:

None.



Union County, NC

Staff Report

Union County Government
Center
500 North Main Street
Monroe, North Carolina
www.unioncountync.gov

File #: 26-240

Agenda Date: 5/4/2026

TITLE:

Resolution Regarding Abandonment of NCDOT Road Maintenance for a Portion of North Main Street in Wingate

INFORMATION CONTACT:

Lee Jenson, Planning, Director, 704-283-3564

ACTION REQUESTED:

Adopt resolution approving proposed abandonment of maintenance.

BACKGROUND:

The NCDOT requests that Union County adopt a resolution in support of abandoning a portion of North Main Street between Wilson Street and McIntyre Road in Wingate in order for the Town of Wingate to begin maintaining that same portion of N. Main St.

FINANCIAL IMPACT:

None.

**North Carolina Department of Transportation
Division of Highways
Request for Abandonment to State Maintained Secondary Road System**

North Carolina

County: Union

Road Description: N Main St (SR-1758) between Wilson St and McIntyre Rd (SR-1631). The total portion inside unincorporated Union County is 0.13 mile.

WHEREAS, the attached petition has been filed with the Board of County Commissioners of the County of Union requesting that the above described road, the location of which has been indicated in red on the attached map, be deleted from the Secondary Road System, and

WHEREAS, the Board of County Commissioners is of the opinion that the above described road should be deleted from the Secondary Road System.

NOW, THEREFORE, be it resolved by the Board of County Commissioners of the County of Union that the Division of Highways is hereby requested to review the above described road, and to abandon the road for maintenance.

CERTIFICATE

The foregoing resolution was duly adopted by the Board of Commissioners of the County of Union at a meeting on the 4th day of May, 2026.

WITNESS my hand and official seal this the _____ day of _____, 20____.

Official Seal

Clerk, Board of Commissioners
County: _____

PLEASE NOTE:

Forward direct with request to the District Engineer, District 3, Division of Highways





Union County, NC

Staff Report

Union County Government
Center
500 North Main Street
Monroe, North Carolina
www.unioncountync.gov

File #: 26-235

Agenda Date: 5/4/2026

TITLE:

Appointments to the Transportation Advisory Board

INFORMATION CONTACT:

Theresa Torres, Human Services Agency, Transportation Director, 704-283-3598

ACTION REQUESTED:

Appoint recommended representatives to the Union County Transportation Advisory Board.

PRIOR BOARD ACTIONS:

None.

BACKGROUND:

The North Carolina Department of Transportation (NCDOT) requires that all Transit Systems have an Advisory Board in place comprised of stakeholders from the service area who have an interest in the services being provided by the Transit Systems. The Transportation Advisory Board (TAB) serves as a steering committee and is expected to discuss unmet needs in the service area, service design, billing rates and fares, and to offer assistance in resolving customer complaints. The Board must include representatives from the elderly, minority, limited English proficiency, disabled and/or low-income populations, or include individuals that represent these consumer groups and are able to encourage the transit system to be more sensitive to the needs of these diverse groups when necessary. The TAB is required to meet at a minimum on a quarterly basis as one means of seeking public involvement. Guidance from NCDOT recommends that the TAB have between 11-17 members. Union County currently has 13 positions filled.

The following individuals have indicated an interest in serving and were unanimously approved by the TAB.

1. Kimberly Jordan
2. Nicole Myers
3. Rasheen Rorie
4. Aleshia Holland

FINANCIAL IMPACT:

None.

Kimberly (Kim) Jordan has been with NC Division of Health & Human Services for over 15 years. She began working with NC Division of Services for the Blind, and is currently working with Employment and Independence for People with Disabilities (EIPD), formerly Vocational Rehabilitation. She began working in Union County with EIPD as a Rehabilitation Counselor, since November 2019. Kim enjoys spending quality time with her 4 grandchildren, either watching their football and soccer games, planting a potted garden, or watching their favorite movies.

Nicole (Nikki) Myers is the Director of Compass Education at South Piedmont Community College, where she serves the IDD population. She is passionate about her students. Nikki works with students to increase their academic skills which helps prepare them for further education and/or employment. She has been in this position at SPCC for 3 years. Prior to this, she worked at UCPS for 17 years. Nikki has been married to her husband, Rich, for 31 years and has lived in Union County for 27 years. She has 2 daughters and one grandson. She's an active member of her church and serves on the Special Olympics steering committee for Union County.

Rasheen Rorie is the program Manager for Medicaid. In her role she utilizes her organizational management skills to encourage autonomy to foster confidence and accountability with her teams. She works to provide quality customer service internally and externally within human services. On a daily basis she utilizes problem-solving skills and conflict resolution to address the various needs of the employees and clients. Rasheen has been with Union County Division of Human Services since 2016 working in both Food and Nutrition Services and Medicaid programs. She has over 7 years of experience in mental health and substance field. Rasheen brings a wealth of knowledge from working in the public and private sector. She has her master's in business administration and is currently pursuing her master's in social work at Wingate University.

Aleshia Holland is the Senior Center Supervisor at the Bazemore Active Adult Center in Monroe. Previously she worked as a Programs Supervisor at the Stanly County Senior Center for over eight years. Aleshia received her bachelor's degree in human services from Gardner Webb University. Since 2014, she has been working with organizations whose mission is to assist with increasing and maintaining independence in older adults. Aleshia thoroughly enjoys being involved in her community. She has served as Vice President on the CARE Café board and has been a member of Relay for Life and United Way committees where she assisted with fundraising. In addition to her work, Aleshia enjoys spending time with her family and volunteering at the Community Inn homeless shelter.



Union County, NC

Staff Report

Union County Government
Center
500 North Main Street
Monroe, North Carolina
www.unioncountync.gov

File #: 26-239

Agenda Date: 5/4/2026

TITLE:

Amendment to the Library Board of Trustees Bylaws

INFORMATION CONTACT:

Nina Chaffin, Library, Director, 704-283-3561

ACTION REQUESTED:

Approve the amendment to Article VII, Paragraph 1 of the Union County Library Board of Trustees bylaws to reduce the required number of meetings from ten (10) per year to six (6) per year.

PRIOR BOARD ACTIONS:

None.

BACKGROUND:

At its regular meeting on March 17, 2026, the Union County Library Board of Trustees discussed the current frequency of its regularly scheduled meetings. During this discussion, members noted that several meetings throughout the year did not include actionable items requiring Board consideration, prompting concerns about the efficient use of time and resources.

As a result, the Library Board considered amending its bylaws to better align meeting frequency with operational needs. The Library Board of Trustees unanimously approved a revision to Article VII, Paragraph 1, reducing the number of required meetings from ten (10) per year to six (6) per year, to be held on a bi-monthly basis.

Because the Board of County Commissioners maintains oversight authority of the Library Board of Trustees, this proposed bylaw amendment is being presented for the Commissioners' review and approval.

FINANCIAL IMPACT:

None.



Union County Public Library

Board of Trustees Bylaws

Article 1. Name

The Board of County Commissioners has established the Board of Trustees of the Union County Public Library (hereinafter referred to as the "Board", the "Board of Trustees" or the "Library Board"), according to the provisions of North Carolina General Statute 153A-265, and has delegated to the Board of Trustees the authority described in these Bylaws.

Article 2. Purpose

The purpose of the Board of Trustees shall be to formulate and adopt, with assistance of the professional library director (hereinafter known as the Director), policies for the delivery of library services for all inhabitants of Union County, North Carolina, and to advise the Board of County Commissioners on matters of library development.

Article 3. Members

The Board of Trustees shall be composed of nine members, appointed by the Union County Board of Commissioners. All members must be residents of Union County and shall be chosen from the populace with reference to their qualifications of such office.

One person shall be appointed to represent each of the following regions:

- Marshville Region – Marshville and eastern Union County
- Monroe Region – City of Monroe and central Union County
- Weddington Region -- including Marvin and Wesley Chapel
- Waxhaw Region -- including Mineral Springs and southwestern Union County
- Union West Region -- Indian Trail, Stallings, Lake Park, Hemby Bridge
- Fairview Region – including Unionville and northwestern Union County

Three seats shall be at-large seats, and the person filling each of these seats may be a resident of any region of the County.

The Union County Board of Commissioners shall designate one of its own members to serve ex-officio on the Library Board. The Commissioner shall serve as a liaison and shall have no vote. Such member from the Board of Commissioners shall serve a term of one year to begin in the month of January.

The Union County Board of Commissioners may remove any member appointed to the Board of Trustees for incapacity, unfitness, misconduct, or neglect of duty. Failure to attend at least two-thirds of regularly scheduled meetings per year shall be interpreted as neglect of duty. Prior to the meetings, the secretary shall be notified of inability to attend.

Members of the Board shall serve without compensation.

Article 4. Terms

Members shall be appointed for two-year terms. Four members shall be appointed in January of odd-numbered years and five members shall be appointed in January of even-numbered years.

All vacancies on the Board shall be immediately reported by the Board of Trustees to the Union County Board of Commissioners, which shall fill the unexpired term for the vacant seat.

Article 5. Quorum

A quorum for the transaction of business at any meeting shall consist of five members. In the event a quorum is not present, any emergency action deemed necessary shall be taken with such action subject to ratification by a quorum at a called special meeting or at the next regular meeting.

Article 6. Officers

The officers shall be a chairperson and a vice-chairperson elected from among the appointed trustees at the annual meeting of the Board of Trustees.

Officers shall be elected to serve a term of one year or until their successors are duly elected.

The Chairperson shall preside at all meetings of the Board, authorize calls for any special meetings of the Board, appoint all committees, execute all documents authorized by the



Board, serve as ex-officio member of all committees, and generally perform all duties associated with that office.

The Vice-Chairperson, in the event of the absence or disability of the Chairperson, or vacancy in that office, shall assume and perform the duties and functions of the Chairperson.

The Director, as Secretary, shall keep a true and accurate record of all meetings of the Board, shall issue notices of all regular and specially called meetings of the Board, and shall perform such other duties as generally associated with the office of Secretary.

The Director shall make pertinent financial reports at regular board meetings.

Article 7. Meetings

There shall be at least six regular meetings of the Board of Trustees each year, held at a regular time and announced to the public via the Union County website. In addition, the schedule for regular meetings shall be filed with the Clerk to the Board of Commissioners.

The annual meeting shall be held at the time of the regular meeting in January of each year.

Special meetings shall be called at the direction of the Chairperson, or at the request of a majority of the Board, for the transaction of business as stated in the call for the meeting. Public notice of special meetings shall be given at least forty-eight hours before the meeting in accordance with the provisions found in North Carolina's open meetings law.

All meetings are open to the public except for matters in which a closed session is permissible under North Carolina law.

The order of business for regular meetings shall include, but not be limited to the following items: (a) Call to order (b) Adoption of the Agenda (c) Public Comment period (d) Presentation to the Board (e) Disposition of minutes of previous meeting (f) Report of the Director (g) Committee Reports (h) Communications (i) Unfinished Business (j) New Business (k) Announcements (l) Adjournment.

Meetings shall be conducted according to standard conventions of Parliamentary Procedure. The rules contained in Suggested Rules of Procedure for Small Local Government Boards shall govern the Board in all cases in which they are applicable, and in which they are not inconsistent with the Bylaws.

Article 8. Powers & Duties of the Library Board

In accordance with North Carolina General Statute 153A-266, the following powers and duties are delegated to the Library Board:

To formulate and adopt programs and policies for the government of the Library which are consistent with state and federal statutes and regulations, and with Union County policies; and which assure public access to library resources and protection of County property.

To make recommendations to the Board of County Commissioners concerning construction and improvements of library buildings and the other structures for the library system.

To advise the County Manager on the appointment of a Library Director, who holds or is eligible for a North Carolina Public Librarian Certificate, as required by the State Aid eligibility requirements.

To establish a schedule of fines and charges for the late return, failure to return, damage to, and loss of library materials, and to take other measures to protect and regulate the use of library resources.

To extend the privileges and use of the library system to nonresidents on terms prescribed by the Board.

To otherwise advise the Board of County Commissioners on library matters.

To make an annual report on the operations of the Library to the Board of County Commissioners and to make an annual report to the Department of Cultural Resources as required by N.C.G.S. 125-5.

In accordance with N.C.G.S. 153-263(3), the Library Board shall make recommendations to the Board of County Commissioners regarding the acquisition of real property for the public library system.

Article 9. The Library Director

Employees of the Union County Public Library shall be employed in accordance with the Personnel Resolution adopted by the Union County Board of Commissioners.

The Director shall be responsible for adherence to the personnel policies of the County; for the direction and supervision of the staff; for the care and maintenance of the physical library property; for the adequate and proper selection of materials in keeping with stated library policies; for the efficiency of library services to the County inhabitants; for the financial

operation within the limitations of budgeted appropriations; and for providing financial, staffing, and operations reports and information to the County Commissioners as they require.

The Director shall keep the Library Board and the Board of County Commissioners abreast of all matters system-wide.

The Library Director may be terminated in accordance with the Union County Personnel Resolution.

Article 10. Amendment

These Bylaws may be amended by a majority vote of members present at a regular meeting of the Board of Trustees at which a quorum is present, provided that the proposed amendment was made known to all members in the call for the meeting.

Article 11. Approval

These Bylaws, and any amendments thereto, are subject to the approval of the Board of County Commissioners.



Union County, NC

Staff Report

Union County Government
Center
500 North Main Street
Monroe, North Carolina
www.unioncountync.gov

File #: 26-157

Agenda Date: 5/4/2026

TITLE:

Budget Amendment - Health Care Fund

INFORMATION CONTACT:

Jason May, Budget & Grants Management, Director, 704-283-3760

ACTION REQUESTED:

Approve Budget Amendment # 21.

PRIOR BOARD ACTIONS:

None.

BACKGROUND:

Union County maintains a self-insured Health Care Fund to account for employee health insurance claims and related costs. During FY 2025, claims activity exceeded budgeted projections, requiring the Health Care Fund to draw on its fund balance reserves to cover the shortfall. This amendment is necessary to restore the Health Care Fund's financial position and ensure adequate reserves are available to support ongoing claims obligations.

This amendment appropriates \$5,000,000 from General Fund unassigned fund balance and \$2,500,000 in lapsed salary savings, for a total transfer of \$7,500,000 to the Health Care Fund. The lapsed salary funds represent personnel vacancy savings realized across County departments during FY 2026. Together, these sources allow the County to replenish the Health Care Fund's fund balance without impacting current service delivery or operational budgets.

FINANCIAL IMPACT:

The Unassigned Fund Balance will decrease by \$5 million. Salaries and benefit lines from general fund department will be reduced by \$2.5 million. The Health Care Fund will be increased by \$7.5 million.

BUDGET AMENDMENT

BUDGET 2026
 FISCAL YEAR FY 2026

REQUESTED BY Jason May
 DATE May 04, 2026

INCREASE

<u>Description</u>	
Fund Balance Appropriation	<u>5,000,000</u>
Transfer to Health Fund	<u>7,500,000</u>
IFT from General Fund	<u>7,500,000</u>
Health Fund Medical Services	<u>7,500,000</u>

DECREASE

<u>Description</u>	
Various Personnel Savings	<u>2,220,364</u>
Salaries & Wages	<u>279,376</u>

Explanation: Appropriate Fund Balance to replenish Health Care Fund Balance

DATE _____

APPROVED BY _____
 Bd of Comm/County Manager
 Lynn West/Clerk to the Board

FOR POSTING PURPOSES ONLY

DEBIT

<u>Code</u>	<u>Account</u>	<u>Amount</u>
10110400-5080		<u>7,500,000</u>
81021070-5383		<u>7,500,000</u>

	Total	<u>15,000,000</u>

CREDIT

<u>Code</u>	<u>Account</u>	
10110400-4991		<u>5,000,000</u>
81021070-4010		<u>7,500,000</u>
Various (see Attached)		<u>2,220,364</u>
10110400-5121		<u>279,636</u>

	Total	<u>15,000,000</u>

Prepared By JM
 Posted By _____
 Date _____

Number 21

Salary			Fica			401K			Retirement			
Org	Object	Amount to decrease	Org	Object	Amount to decrease	Org	Object	Amount to decrease	Org	Object	Amount to decrease	
10115120	5121	\$2,824	10115120	5131	\$216	10115120	5134	\$141	10115120	5136	\$406	\$3,587
10115130	5121	\$24,463	10115130	5131	\$1,871	10115130	5134	\$1,223	10115130	5136	\$3,518	\$31,075
10115210	5121	\$3,000	10115210	5131	\$230	10115210	5134	\$150	10115210	5136	\$431	\$3,811
10131200	5121	\$173,680	10131200	5131	\$13,287	10131200	5134	\$8,684	10131200	5136	\$24,975	\$220,626
10111110	5121	\$51,232	10111110	5131	\$3,919	10111110	5134	\$2,562	10111110	5136	\$7,367	\$65,080
10120110	5121	\$80,126	10120110	5131	\$6,130	10120110	5134	\$4,006	10120110	5136	\$11,522	\$101,784
10130642	5121	\$90,560	10130642	5131	\$6,928	10130642	5134	\$4,528	10130642	5136	\$13,282	\$115,298
10130646	5121	\$26,000	10130646	5131	\$1,989	10130646	5134	\$1,300	10130646	5136	\$3,739	\$33,028
10130700	5121	\$900	10130700	5131	\$69	10130700	5134	\$45	10130700	5136	\$129	\$1,143
10123010	5121	\$30,234	10123010	5131	\$2,313	10123010	5134	\$1,512	10123010	5136	\$4,348	\$38,406
10117410	5121	\$23,000	10117410	5131	\$1,760	10117410	5134	\$1,150	10117410	5136	\$3,307	\$29,217
10130540	5121	\$4,000	10130540	5131	\$306	10130540	5134	\$200	10130540	5136	\$575	\$5,081
10130541	5121	\$10,000	10130541	5131	\$765	10130541	5134	\$500	10130541	5136	\$1,438	\$12,703
10130542	5121	\$70,000	10130542	5131	\$5,355	10130542	5134	\$3,500	10130542	5136	\$10,066	\$88,921
10130543	5121	\$75,000	10130543	5131	\$5,738	10130543	5134	\$3,750	10130543	5136	\$10,785	\$95,273
10111210	5121	\$78,053	10111210	5131	\$5,971	10111210	5134	\$3,903	10111210	5136	\$11,224	\$99,151
10130505	5121	\$1,000	10130505	5131	\$77	10130505	5134	\$50	10130505	5136	\$144	\$1,270
10130800	5121	\$113,000	10130800	5131	\$8,645	10130800	5134	\$5,650	10130800	5136	\$16,249	\$143,544
10111310	5121	\$48,580	10111310	5131	\$3,716	10111310	5134	\$2,429	10111310	5136	\$6,986	\$61,711
10111350	5121	\$16,260	10111350	5131	\$1,244	10111350	5134	\$813	10111350	5136	\$2,338	\$20,655
10115510	5121	\$4,540	10115510	5131	\$347	10115510	5134	\$227	10115510	5136	\$653	\$5,767
10122010	5121	\$69,880	10122010	5131	\$5,346	10122010	5134	\$3,494	10122010	5136	\$10,049	\$88,769
10115510	5121	\$85,000	10115510	5131	\$6,503	10115510	5134	\$4,250	10115510	5136	\$12,223	\$107,976
10115510	5121	\$4,997	10115510	5131	\$382	10115510	5134	\$250	10115510	5136	\$719	\$6,348
10115601	5121	\$60,000	10115601	5131	\$4,590	10115601	5134	\$3,000	10115601	5136	\$8,628	\$76,218
10115612	5121	\$11,215	10115612	5131	\$858	10115612	5134	\$561	10115612	5136	\$1,613	\$14,246
10120210	5121	\$25,775	10120210	5131	\$1,972	10120210	5134	\$1,289	10120210	5136	\$3,706	\$32,742
10111410	5121	\$43,758	10111410	5131	\$3,347	10111410	5134	\$2,188	10111410	5136	\$6,292	\$55,586
10123101	5121	\$60,000	10123101	5131	\$4,590	10123101	5134	\$3,000	10123101	5136	\$8,628	\$76,218
10130501	5121	\$9,000	10130501	5131	\$689	10130501	5134	\$450	10130501	5136	\$1,294	\$11,433
10130505	5121	\$4,126	10130505	5131	\$316	10130505	5134	\$206	10130505	5136	\$593	\$5,241
10130510	5121	\$28,035	10130510	5131	\$2,145	10130510	5134	\$1,402	10130510	5136	\$4,031	\$35,613
10130511	5121	\$8,116	10130511	5131	\$621	10130511	5134	\$406	10130511	5136	\$1,167	\$10,310
10130512	5121	\$12,453	10130512	5131	\$953	10130512	5134	\$623	10130512	5136	\$1,791	\$15,819
Public Health	5121	\$126,231	Public Heal	5131	\$9,657	Public Heal	5134	\$6,312	Public Heal	5136	\$18,152	\$160,351
10128110	5121	\$35,000	10128110	5131	\$2,678	10128110	5134	\$1,750	10128110	5136	\$5,033	\$44,461
10130610	5121	\$12,000	10130610	5131	\$918	10130610	5134	\$600	10130610	5136	\$1,726	\$15,244
10130622	5121	\$25,236	10130622	5131	\$1,931	10130622	5134	\$1,262	10130622	5136	\$3,629	\$32,057
10130628	5121	\$33,142	10130628	5131	\$2,535	10130628	5134	\$1,657	10130628	5136	\$4,766	\$42,100
10130629	5121	\$15,360	10130629	5131	\$1,175	10130629	5134	\$768	10130629	5136	\$2,209	\$19,512
10130632	5121	\$26,801	10130632	5131	\$2,050	10130632	5134	\$1,340	10130632	5136	\$3,854	\$34,045
10130633	5121	\$92,981	10130633	5131	\$7,113	10130633	5134	\$4,649	10130633	5136	\$13,371	\$118,114
10130663	5121	\$32,143	10130663	5131	\$2,459	10130663	5134	\$1,607	10130663	5136	\$4,622	\$40,831
Total		\$1,747,905	Total		\$133,715	Total		\$87,395	Total		\$251,579	\$2,220,364



Union County, NC

Staff Report

Union County Government
Center
500 North Main Street
Monroe, North Carolina
www.unioncountync.gov

File #: 26-234

Agenda Date: 5/4/2026

TITLE:

Bid Award and Construction Contract - Detention Center Walk-in Freezer and Cooler Replacement

INFORMATION CONTACT:

Linda Whitaker, Facilities and Fleet Management, Assistant Director Design and Construction, 704-420-2626

ACTION REQUESTED:

1) Award construction contract to Garmon Mechanical Service, Inc. in the amount of \$159,392.10; 2) authorize the County Manager to, i) negotiate and execute an agreement with Garmon Mechanical Service, Inc. substantially consistent with this agenda item, ii) exercise any renewal or extension term options set forth in the agreement, and iii) terminate the agreement if deemed in the best interest of Union County, each in the County Manager's discretion; and 3) adopt Resolution Providing Notice of Construction of the Detention Center Walk-in Freezer and Cooler Replacement project.

PRIOR BOARD ACTIONS:

None.

BACKGROUND:

The existing walk-in freezer and cooler serving the detention center are at the end of their service life. The project consists of the complete removal of the existing walk-in freezer and cooler units and the installation of new insulated wall and ceiling panels, insulated walk-freezer and cooler doors and a new refrigeration system to better serve the detention center.

On January 26, 2026, Procurement and Contract Management partnered with Facilities and Fleet Management to issue an Invitation for Bid IFB 2026-051 Detention Center Walk-in Freezer and Cooler and Replacement. On March 10, 2026, two (2) bids were received. Because less than three (3) bids were received, the bids remained sealed and returned to the bidders. On March 10, 2026, IFB 2026-051 was issued to rebid the project. On March 25, 2026, (3) bids were received for the titled project. All bids were tabulated, reviewed and certified by Facilities and Fleet Management. The bids ranged from \$159,392.10 - \$287,888.34. Staff recommend the project be awarded to the lowest, responsive, responsible bidder, Garmon Mechanical Service, Inc., in the amount of \$159,392.10.

FINANCIAL IMPACT:

Funding is available within the adopted capital account Union County Jail Block Renovations, 40080112, to support the construction contract amount of \$159,392.10.

1 NOTICE OF ADVERTISEMENT

Union County, North Carolina
IFB No. 2026-051
Detention Center Walk-In Freezer and Cooler Replacement

Sealed bids for a Union County Detention Center Walk-In Freezer will be received by the Union County Procurement Department *until 2:00 PM local time on February 25, 2026*, at the Union County Procurement Department, 610 Patton Avenue, Monroe, NC 28110, at which time the bids will be opened and read aloud. **Late bids will not be accepted.**

If a Bid is sent by mail or other delivery system, the sealed envelope containing the Bid shall be enclosed in a separate package plainly marked on the outside with the notation “**BID ENCLOSED – 2026-051**” and shall be addressed to Union County Procurement Department, Attn: Juan Rodriguez-Cruz, 610 Patton Avenue, Monroe, NC 28110.

A Non-Mandatory Pre-Bid Meeting and Site Visit will be held on **February 10, 2026, at 9:30 AM local time** at the Union County Detention Center, 3344 Presson Road, Monroe NC 28110. Attendance at this meeting is strongly encouraged.

Project Scope of Work: Complete removal of existing walk-in freezer and cooler units, site preparation, installation of new insulated panels for walls and ceiling, installation of new doors, installation of a new refrigeration system, electrical connections, proper sealing and caulking, and final testing and clean-up; ensuring compliance with local building codes and food safety standards throughout the process.

Copies of the solicitation may be obtained free of charge from the locations listed below:

1. Download the Solicitation Documents from the Union County website:
<https://www.unioncountync.gov/departments/bids-procurement/current-bids>
2. Download the Solicitation Documents from the State of North Carolina eVP website:
<https://evp.nc.gov/solicitations/> (Search County of Union)

Bidders must have a Class 1 Refrigeration License and Electrical License to do work in the State of North Carolina.

All questions about the meaning or intent of the Bidding Documents are to be submitted in writing to the Procurement contact person listed on the cover page (Juan.Rodriguez-Cruz@unioncountync.gov). Deadline for questions is **February 17, 2025, at 3:00 PM local time.**

Bidders are required to comply with the non-collusion requirements set forth in the Bidding Documents.

The County reserves the right to reject any and/or all bids, including, without limitation, nonconforming, nonresponsive, unbalanced, or conditional bids. The County also reserves the right to waive informalities and request clarification as needed.

Union County encourages good faith effort outreach to Minority Businesses (HUB Certified) and Small Businesses.



Invitation for Bid No. 2026-051

**Detention Center Walk-in Freezer and cooler
Replacement**

ADDENDUM No. 1

ISSUE DATE: February 19, 2026

Responding Bidders on this project are hereby notified that this Addendum shall be made a part of the above named IFB document.

The following items add to, modify, and/or clarify the IFB documents and shall have the full force and effect of the original Documents. This Addendum shall be acknowledged by the Offeror in the IFB document.

A) Delete/Add/Replace Section

1. **Delete:** IFB Due Date of February 25, 2026, throughout the IFB document and **REPLACE** with the **new IFB Due Date of March 10, 2026, at 2:00 PM EST** throughout the IFB document.

END OF ADDENDUM No.1



Invitation for Bid No. 2026-051

Detention Center Freezer and Cooler Replacement

.....

ADDENDUM No. 2

ISSUE DATE: February 25, 2026

Responding Offerors on this project are hereby notified that this Addendum shall be made a part of the above named RFP document.

The following items add to, modify, and/or clarify the RFP documents and shall have the full force and effect of the original Documents. This Addendum shall be acknowledged by the Offeror in the RFP document.

Delete/Add/Replace Section

1. Add- Approved Alternate Equipment

- This Addendum is issued to provide clarification regarding alternate equipment submissions. All other terms, conditions, and specifications of IFB No. 2026-051 remain unchanged.
 - The County has received a request to consider alternate walk-in cooler/freezer equipment.
 - Manufacturers utilizing Extruded Polystyrene (XPS) insulation panels may be submitted as an alternate provided the proposed equipment meets or exceeds all performance requirements outlined in Section 6 – Specifications of the IFB, including but not limited to the following:
 - Minimum 4-inch insulation thickness.
 - Flame spread and smoke developed ratings meeting applicable code requirements.
 - R-value equal to or greater than specified performance criteria.
 - Compliance with NSF, UL, DOE, and all applicable building and food safety codes.
 - Refrigeration components meeting or exceeding specified capacity, voltage, defrost type, refrigerant, and efficiency requirements.
 - Manufacturer literature provided (Amerikooler architectural specifications and associated refrigeration submittals) is attached for informational purposes only. The inclusion of such materials does not constitute endorsement of any specific manufacturer.
 - Any bidder proposing alternate equipment must clearly identify deviations from the original specifications in accordance with Section 6.16 – Deviations. Proposed alternates will be evaluated for responsiveness and compliance during the bid review process.

Delete- Original appendix A and replace with Updated Appendix A.

Addendum 2 Attachments- Manufacturer literature at the end of addendum

Question/Answer Section

1. **Question:** What are the procedures for crews to check in and what hours are we allowed to work on site?

Answer: Per Section 7.5 of IFB 2026-051, all personnel working on-site at the Detention Center are subject to a background check. A Non-Disclosure Agreement (Appendix E) must be submitted and approved prior to beginning work. Contractors must provide a daily tool list before starting work, and additional access procedures will be coordinated with the Sheriff's Office.

Per Section 5 (Scope), approved work hours are Monday through Friday, 7:00 a.m. to 5:00 p.m. Work on County holidays is not permitted. Noisy work shall not begin before 8:00 a.m. Weekend work requires prior approval from Union County Facilities and Fleet Management. Alternative work hours may be negotiated with the County if approved in advance.

2. **Question:** could you confirm if those are the two boxes?

Answer: There are three units in the area now one freezer and two coolers units Two units are going back in. One freezer unit and One cooler unit.

3. **Question:** One was the combo and the other was just the cooler?

Answer: The new units will be one freezer unit and one cooler unit. See in the specifications 6.1 for the Freezer unit and 6.2 is written for the Cooler unit.

End of Addendum No. 2

9 APPENDIX A – BID FORM

IFB No. 2026-051 Detention Center Walk-In Freezer and Cooler Replacement

SUBMIT WITH BID

Name of Bidder: _____

The undersigned Bidder hereby declares that he has carefully investigated the scope of work and having thoroughly familiarized himself with the Contract Documents relative hereto and has read all special provisions furnished prior to the opening of the bids; that he has satisfied himself relative to the work to be performed. The bidder further declares that he and his subcontractors have fully complied with NCGS 64, Article 2 in regard to E-Verification as required by N.C. General Statute 143-129(j). The bidder agrees to hold the proposed bid price for 90 days.

The bidder proposes and agrees if this proposal is accepted, to contract with Union County Government, in the form of contract specified, to provide all necessary labor, equipment, materials, machinery, tools, apparatus, transportation, services, fees, permits, etc., to complete the construction of Union County Detention Center Walk-In Freezer and Cooler Replacement all in accordance with the aforementioned Contract Documents to the full and entire satisfaction of Union County Government, with definite understanding that no money will be allowed for extra work except for the lump sum.

Provide 5% of the base bid price as an Owner contingency allowance and provide a Total Base Bid Price. Any funds not used from this allowance will be returned to the Owner by deduct change order.

This Bid Form must be completed in its entirety as-is and submitted with bid. The Total Bid is considered a turn-key cost for the completion of this project. *Bidder's may not write-in exceptions or additional expenses.*

Description	Estimated Days	Unit Cost	Base Bid
Trenton - M/ TEZA025L8HT3DF, 2.5 HP, Low Temp Refrigeration Condensing Unit 208/230 3P.	N/A		
Trenton – M/TPLP211LES2DR6, 2 Fan Evap., 11000 BTU, Low Temp Electric Defrost 208/230 1P.	N/A		
Trenton – M/TEZA008H8HT3DB, .8 HP Refrigeration Condensing Unit 208/230 3P.	N/A		
Trenton – M/TPLP209MAS1DR6, 2 Fan Evap., 9000 BTU 115 V 1P.	N/A		
Labor	N/A		
Freezer/Cooler Rental Per Day			
Other			
Base Bid:			
5% of Base Bid =Owner's Contingency:			
Base Bid + Contingency = Total Bid:			

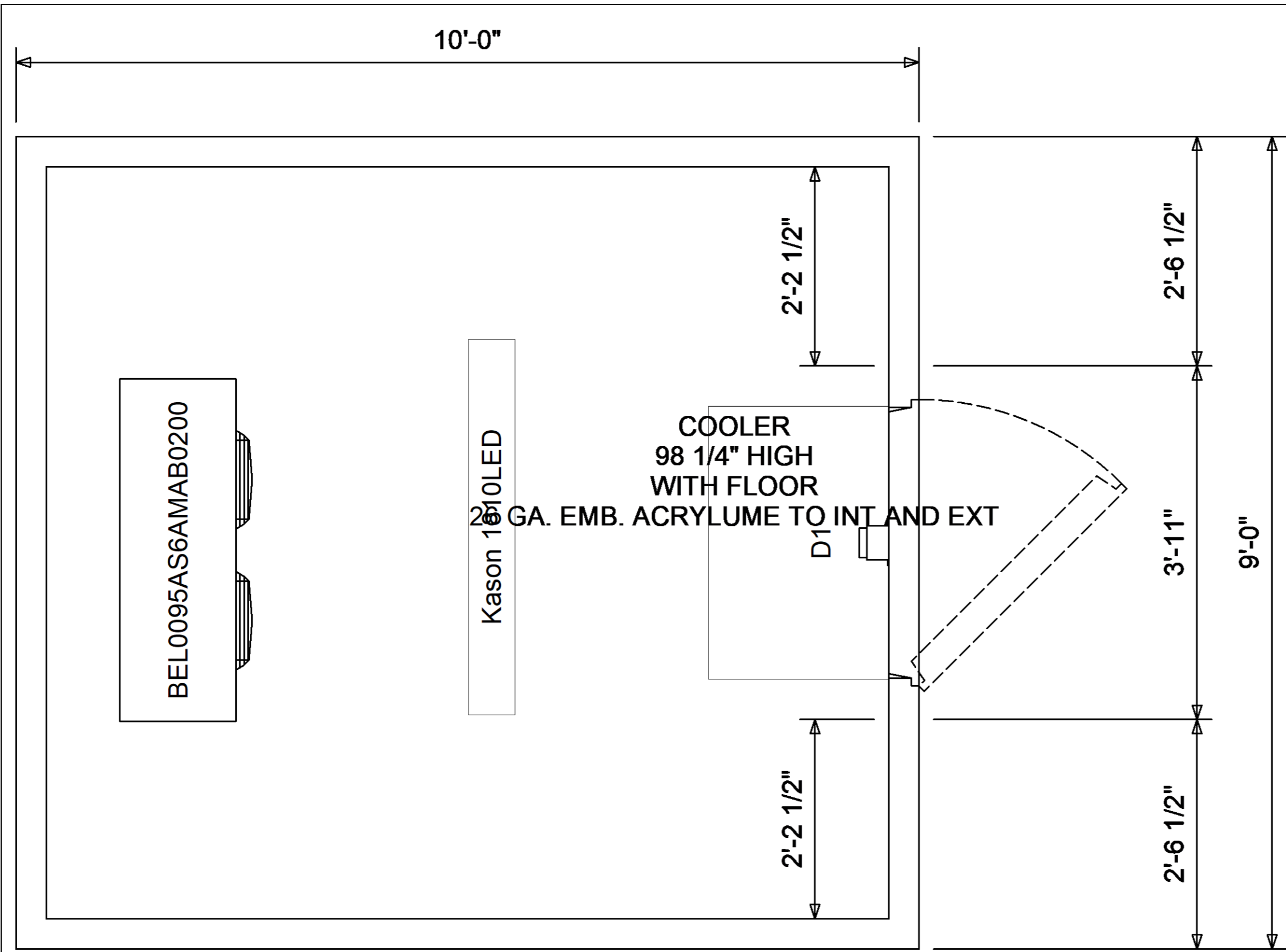

General Arrangement

-SPECIFICATION-
Box Height: Cooler 8'-2 1/4" (7'-6 1/4" Interior)
Insulation: 4" thick AK-XPS4 Extruded foam UL classified core flame spread 15, Smoke rating less than 165
Compartment 1 - Cooler
D1 - (1) Standard 36" x 76" Left hinged flush door with brushed hardware. Interior & Exterior finish: 26 Ga. Stucco Embossed Acrylume. 36" kickplates to interior and exterior of door. Heavy duty deadbolt handle latch with 1/4 turn inside release. 75LC Modularm Multi-Monitor Controller with Temperature Probe and Door Open/Close Sensor for Coolers or Freezers Wired and Installed with MD-1 Motion sensor, IP-1 Panic button/light, 75LC Wireless Mod , 75LC Wireless Communicator. 1807 11w, Vapor Proof, 120V. LED fixture. 82 Lumens /watt Angled face . Requires 115vac. 1 amps.
 With third hinge, 12 x 12 heated frame & glass viewing window, Internal Ramp 24" deep x 36" wide
Refrigeration:
 (1) 1 HP Bohn DOE Compliant Outdoor Condensing Unit, Model BCH0010MBACZA0000, 208-230/1/60, MCA 15 Amps, BTUH 9700, Medium Temperature, Scroll, Air-cooled, R-448A, This refrigeration system is designed and certified for use in walk-in cooler applications - A
 (1) Bohn DOE Compliant BEL0095AS6AMAB0200, 115/1/60, Low Profile Air Defrost, 1.8 Fan Amps with 2-Speed EC Motor (Totally Enclosed) motor
 (1) Extended 4 year compressor Warranty

By signing the approval print document, you confirm that all dimensions and specifications are accurate. Once approved, your order will be scheduled for production. Please note that any changes made after approval will incur additional cost and may affect the scheduled ship date.
 Customer Approval:

Quote No : 26-05065 Revision :
 Customer : All Bids (IFS)

Project : Union County Detention Center
 Page 1 of 4

Date : 02/19/2026



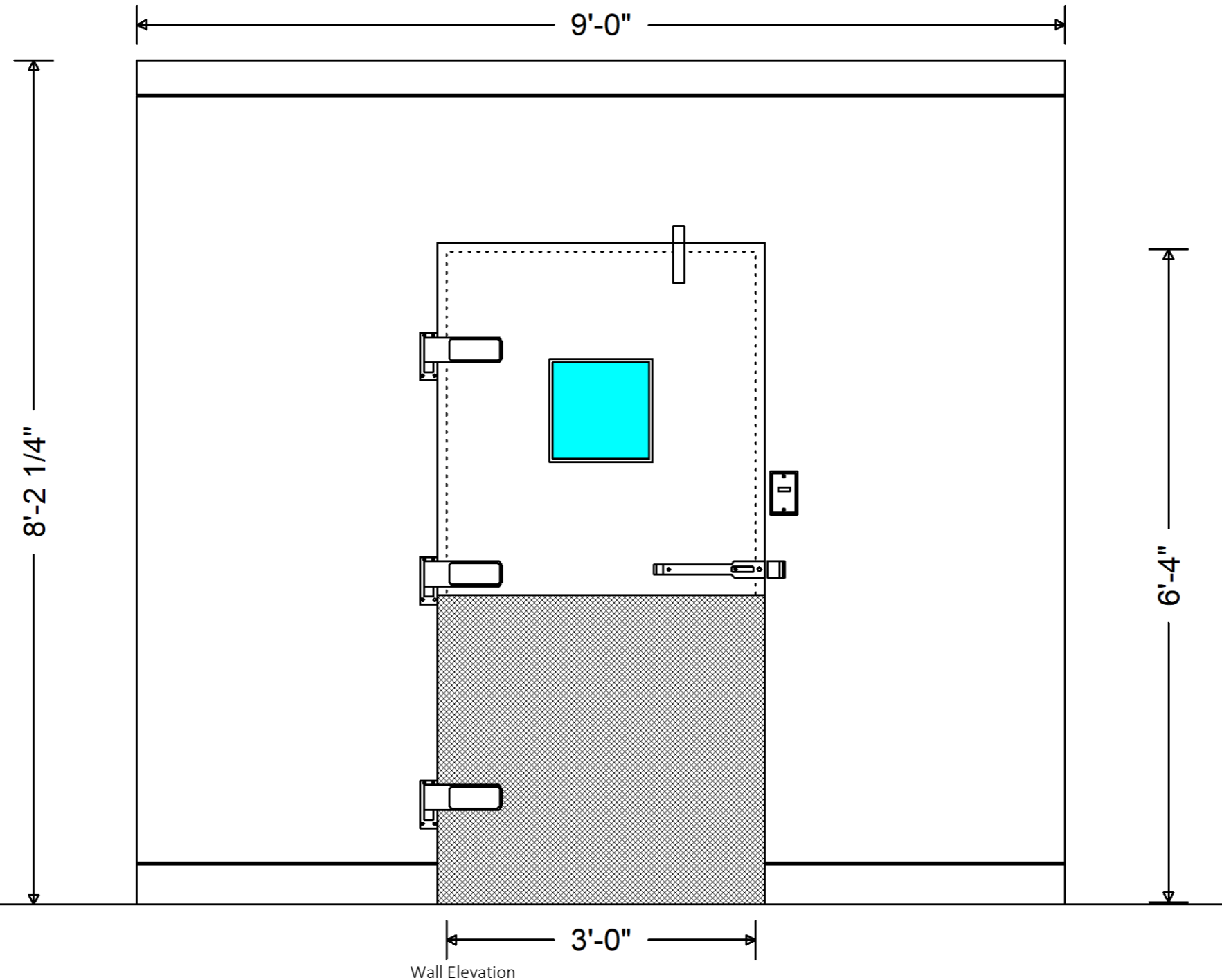

-SPECIFICATION-Continued

Wall Panels

Interior Finish: 26 Ga. Stucco Embossed Acrylume
 Exterior Finish: 26 Ga. Stucco Embossed Acrylume

Ceiling Panels

Interior Finish: 26 Ga. Stucco Embossed Acrylume
 Exterior Finish: 26 Ga. Stucco Embossed Acrylume

Floor Panels

NSF Floor panel rated for 1250 LBS/ SQ. FT.
 20 Ga. Stainless Steel Type 304 Textured Integral. Reinforced with coated 0.5" plywood underlay

Application: Hand Trucks, Dunnage Racks, Beer Kegs, Log Carts, Dollie Carts

Accessories Shipped Loose

(1) 48" LED LIGHT STRIP FIXTURE 96 LUMENS /WATT 120VAC, 0.33 AMPS - TEMP RANGE: -30°F-104°F, SHIP LOOSE RECOMMENDED ONE FIXTURE EVERY 144 SQ. FT. AT 12' HIGH

Notes:

* Allow a minimum of 2" clearance around all sides of the walk-in for proper air circulation

Customer Approval:



Quote No : 26-05065 Revision :
 Customer : All Bids (IFS)

Project : Union County Detention Center
 Page 2 of 4

Date : 02/19/2026

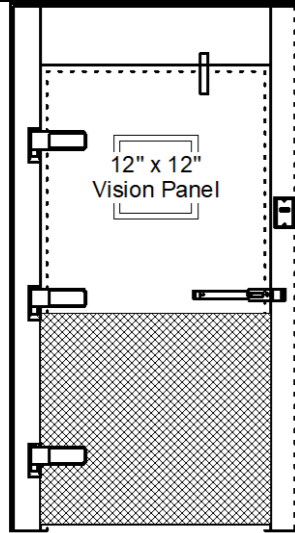

D1

Quote No : 26-05065 Revision :

Project : Union County Detention Center

Date : 02/19/2026

Customer : All Bids (IFS)

Page 3 of 4



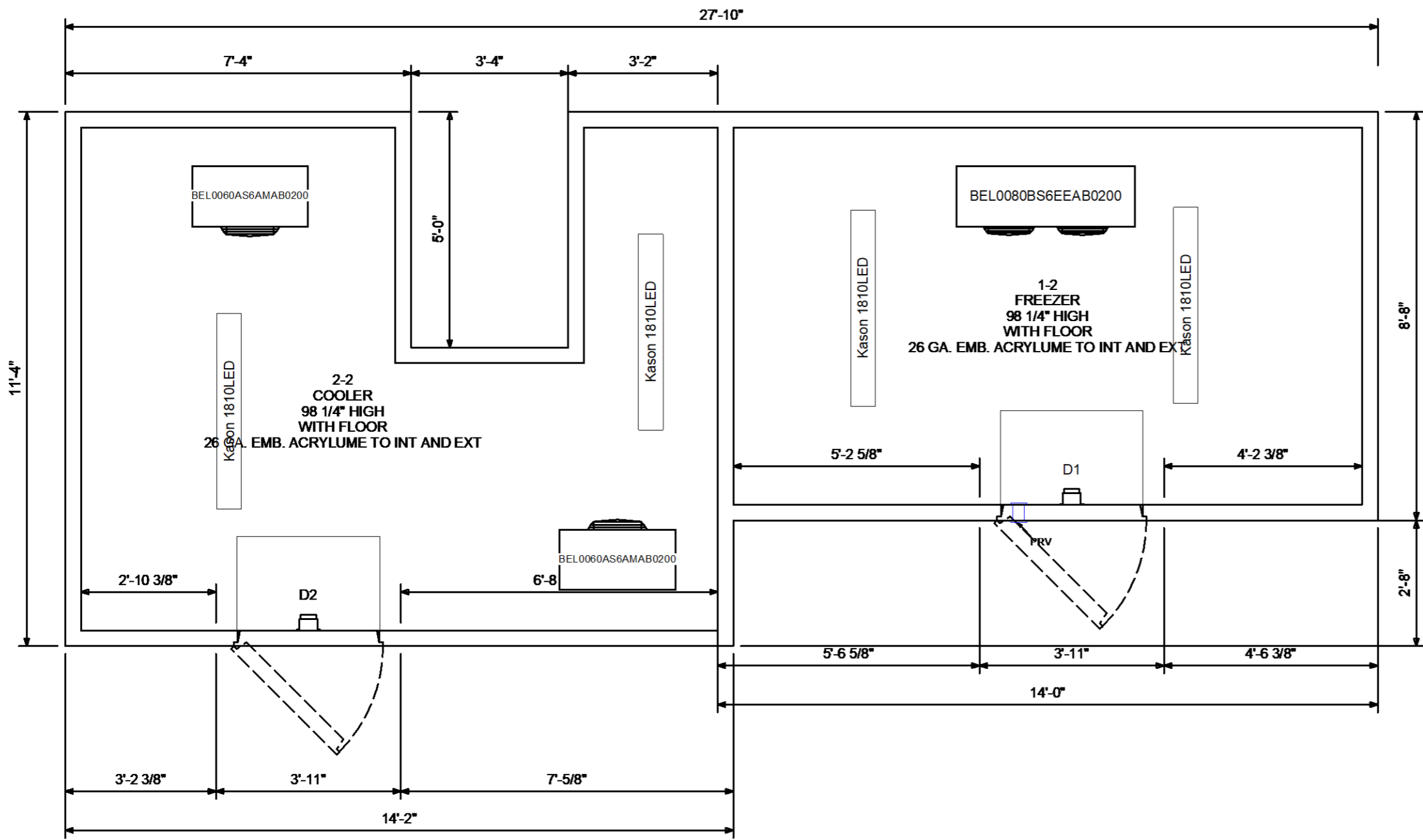

General Arrangement

-SPECIFICATION-

Box Height: Freezer 8'-2 1/4" (7'-6 1/4" Interior)
Cooler 8'-2 1/4" (7'-6 1/4" Interior)

Insulation: 4" thick AK-XPS4 Extruded foam UL classified core flame spread 15, Smoke rating less than 165

Compartment 1 - Freezer

D1 - (1) Standard 36" x 76" Left hinged flush door with brushed hardware. Interior & Exterior finish: 26 Ga. Stucco Embossed Acrylume. 36" kickplates to interior and exterior of door. Energy saving temperature regulating thermostat heater wire and heated relief vent. Heavy duty deadbolt handle latch with 1/4 turn inside release. 75LC Modularm Multi-Monitor Controller with Temperature Probe and Door Open/Close Sensor for Coolers or Freezers Wired and Installed with MD-1 Motion sensor, IP-1 Panic button/light, 75LC Wireless Mod , 75LC Wireless Communicator. 1807 11w, Vapor Proof, 120V. LED fixture. 82 Lumens /watt Angled face . Requires 115vac. 2.2 amps.
With third hinge, 12 x 12 heated frame & glass viewing window, Internal Ramp 24" deep x 36" wide

By signing the approval print document, you confirm that all dimensions and specifications are accurate. Once approved, your order will be scheduled for production. Please note that any changes made after approval will incur additional cost and may affect the scheduled ship date.

Customer Approval:

Quote No : 26-05067 Revision :

Project : Union County Detention Center

Date : 02/19/2026

Customer : All Bids (IFS)

Page 1 of 4



-SPECIFICATION-Continued

Refrigeration:

(1) 3 HP Bohn DOE Compliant Outdoor Condensing Unit, Model BCH0030LBACZA0000, 208-230/1/60, MCA 37.5 Amps, Low Temperature, Scroll, Air-cooled, R-448A, This refrigeration system is designed and certified for use in walk-in freezer applications - AWEF3.15, 1 (9058 Btu/hr @ -10°F room temperature and 95°F ambient)

(1) Bohn DOE Compliant BEL0080BS6EEAB0200, 208-230/1/60, Low Profile Electric Defrost, 1 Fan Amps with 1-Speed EC Motor (Totally Enclosed) motor

(1) Extended 4 year compressor Warranty

Wall Panels

Interior Finish: 26 Ga. Stucco Embossed Acrylume

Exterior Finish: 26 Ga. Stucco Embossed Acrylume

Ceiling Panels

Interior Finish: 26 Ga. Stucco Embossed Acrylume

Exterior Finish: 26 Ga. Stucco Embossed Acrylume

Floor Panels

NSF Floor panel rated for 1250 LBS/ SQ. FT.

20 Ga. Stainless Steel Type 304 Textured Integral. Reinforced with coated 0.5" plywood underlay

Application: Hand Trucks, Dunnage Racks, Beer Kegs, Log Carts, Dollie Carts

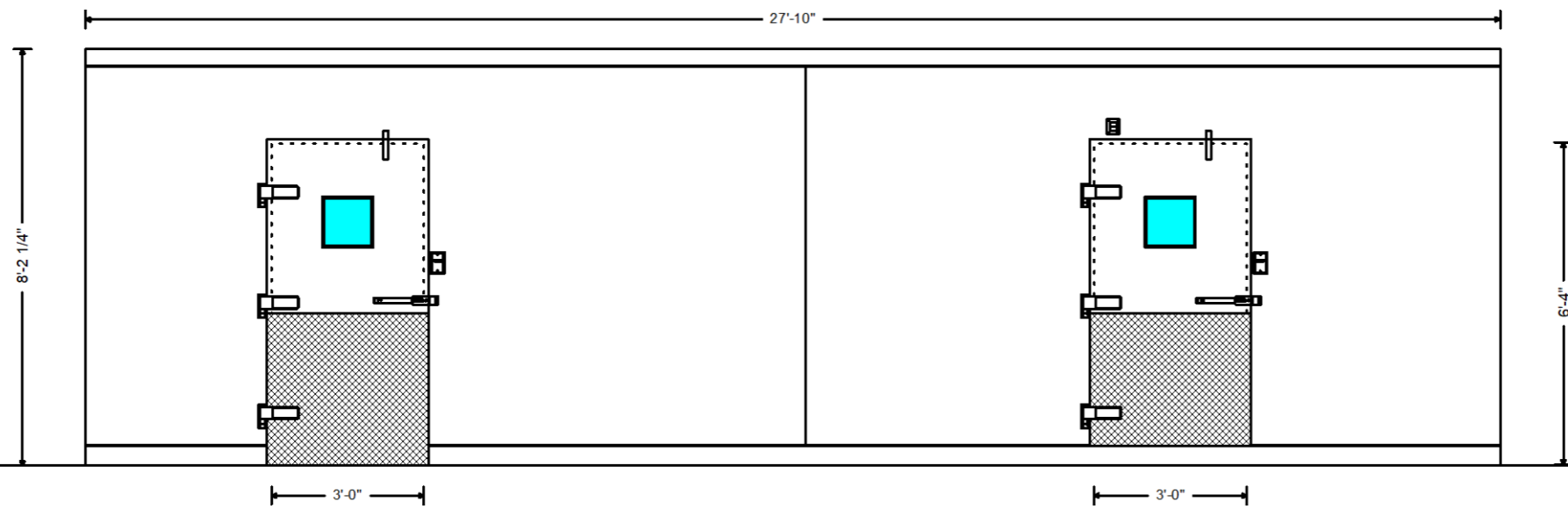

Wall Elevation

Customer Approval:

Quote No : 26-05067 Revision :

Project : Union County Detention Center

Date : 02/19/2026

Customer : All Bids (IFS)

Page 2 of 4



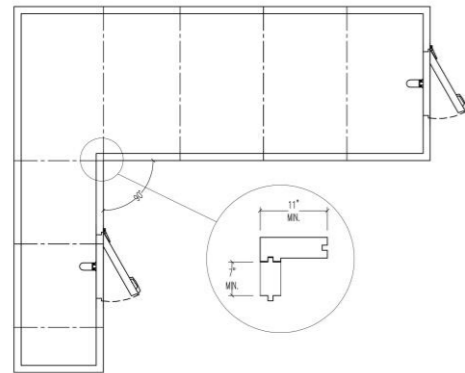

INVERTED L SHAPE CORNER

10049: INVERTED L SHAPE EXTERIOR WALL CORNER WITH FLOOR EACH

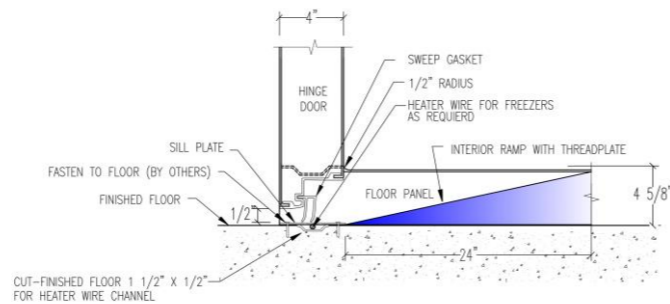

INTERIOR RAMP 24\"/>

10064: INTERIOR RAMP 24\"/>

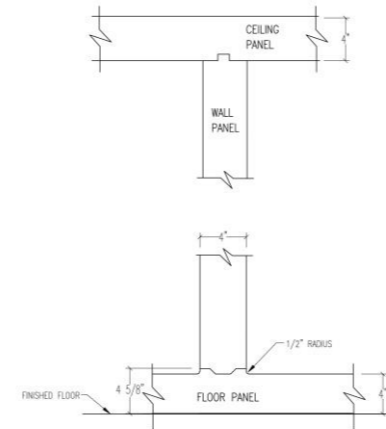

STANDARD PARTITION WALL

20012: STANDARD PARTITION WALL UPCHARGE, WITH FLOOR (PER LINEAR FT. OF PARTITION WALL LENGTH)

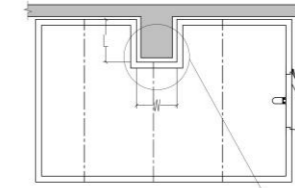

INVERTED \"U\" SHAPE

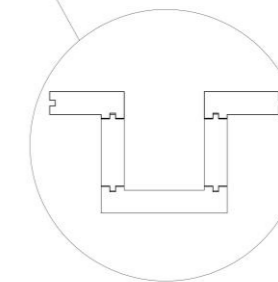

292: INVERTED \"U\" SHAPE EXTERIOR WALK IN COLUMN CUTOUT WITH FLOOR

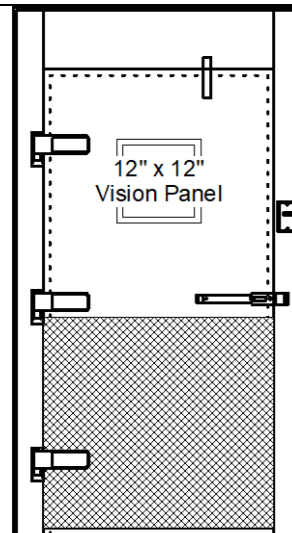

D2

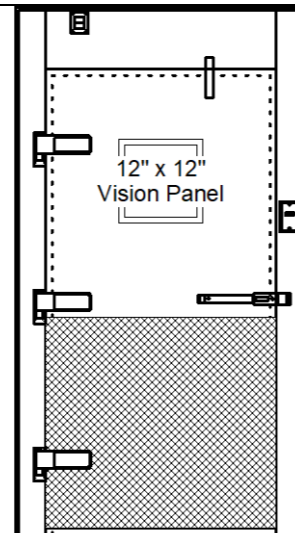

D1

Quote No : 26-05067 Revision :

Project : Union County Detention Center

Date : 02/19/2026

Customer : All Bids (IFS)

Page 3 of 4



BCH0030LBACZA0000 - SUBMITTAL



Project Name:	-	Project Location:	-
Quote ID:	-	Item #:	1000
Submitted For:	-	Submitted On:	-
Submitted By:	-	Submitted From:	-
Identity #:	-	Tag:	-

For Record

For Approval

By: _____

Date: _____

General Product Information

Product Family:	HTS	Compressor Brand:	Copeland
Application:	Outdoor	Compressor Type:	Scroll
Temperature Range:	Low Temp	Compressor Hp:	3
Voltage: (Volts/Ph/Hz)	208-230/1/60	Compressor Model:	ZF09K4E-PFV-231
Refrigerant Type:	R448A	Number of Compressor(s):	1
Piping:	Standard	Coil Type:	Microchannel

Technical Information

Performance Data

Ambient Temperature (°F)	Saturated Suction Temperature (°F)	Application Capacity* (BTU/H)	Altitude (ft)	AWEF Value
95	-20	9,120	0	3.15

Electrical Data

Compressor(s)		Fan Motor(s)			Electric Ratings						
RLA	LRA	Quantity	Hp	FLA	Defrost Type	High or Low Amps?	Number of Contactors	MCA	MOPD	Evap. Fan Amps	Defrost Heater Amps
12.8	88	2	1/15	1	AIR DEFROST	-	-	20	25	-	-

Unit Specifications

Connections (in.)		Receiver 90% Full (lbs)		Fan Blade(s) Diameter (in)	Sound Data (dB)	Approx. Net Weight (lbs)
Liquid Line	Suction	Standard	Over Sized			
0.5	0.875	14	20	14	64	239

Dimensional Drawing(s)

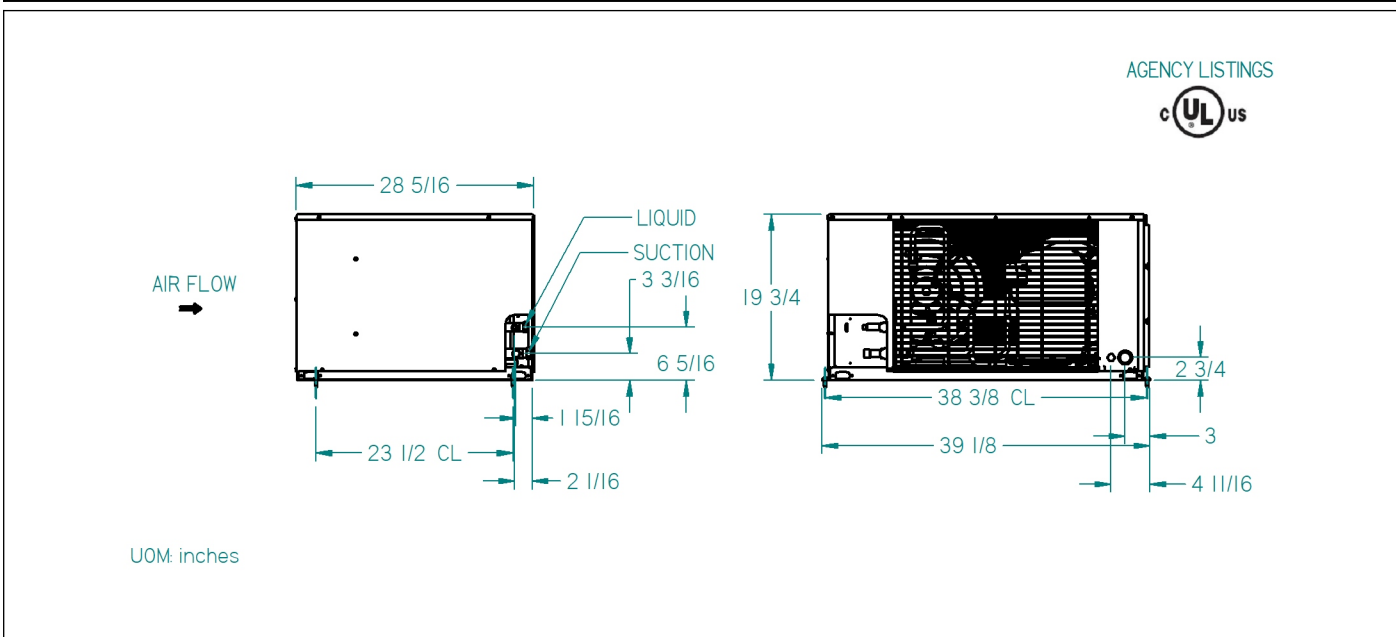



Project Name:	-	Project Location:	-
Quote ID:	-	Item #:	1000
Submitted For:	-	Submitted On:	-
Submitted By:	-	Submitted From:	-
Identity #:	-	Tag:	-

Standard Features

CABINET AND CONSTRUCTION

- MICROCHANNEL COIL TECHNOLOGY STANDARD ON ALL UNITS
- PAINTED STEEL CABINETS FOR SUPERIOR STRENGTH AND CORROSION PROTECTION
- HEAVY DUTY, STEEL, 1-1/2" TALL BASE

SERVICEABILITY

- SUCTION SERVICE VALVES FOR HERMETIC AND SCROLL COMPRESSORS LOCATED OUTSIDE THE CABINET FOR QUICK INSTALLATIONS.
- RECEIVER WITH FUSIBLE PLUG, LIQUID SHUTOFF VALVE AND CHARGING PORT IS STANDARD
- LARGE ELECTRICAL PANEL FOR EASE OF ACCESS
- PREFABRICATED WIRING HARNESES FOR TIGHT CRIMP CONNECTIONS AND CONSISTENT LABELING
- UNIT STAYS ON IF THE HOOD IS REMOVED FOR SERVICING
- SIGHT GLASS IS EASILY VIEWABLE

QUALITY

- ALL UNITS ARE COMPLETELY LEAK TESTED IN A HELIUM ENVIRONMENT, BUMP TESTED AND ALLOWED TO CYCLE OFF ON THE HIGH AND LOW PRESSURE CONTROL. EACH UNIT HAS A COPY OF THE RUN DATA SHIPPED INSIDE THE ELECTRICAL PANEL
- ELECTRICAL CIRCUITS ARE COMPLETELY CHECKED FOR CONTINUITY
- PIPING IS LAID OUT TO MINIMIZE STRESS AND VIBRATION AND IS PRE-BENT TO ELIMINATE LEAKS
- ENCAPSULATED, AUTO-RESET, HIGH AND LOW PRESSURE CONTROLS TO ELIMINATE LEAKS (ADJUSTABLE LOW PRESSURE CONTROL STANDARD)

Options

Mounted Options

- BRAND LABEL OPTION - BOHN
- Pressure Options - ADJUSTABLE LOW - FIXED HIGH
- Crankcase Heater - CRANKCASE HEATER
- Fused Disconnect - NO FUSED DISCONNECT
- Coil Selection - MICROCHANNEL COIL
- Liquid Line Options - FILTER DRIER AND SIGHT GLASS
- Discharge Line Options - HEAD PRESSURE VALVE 100#
- BASE LEG BRACKET OPTIONS - None
- COMPLIANCE - DOE COMPLIANT
- Defrost Timer Options - NO TIMER
- Motor - FIXED SPEED EC
- Phase Loss Monitor - NONE
- Cabinet Selection - Painted
- Receiver Options - STANDARD
- Suction Line Options - SUCTION TUBE ONLY
- PRE-CHARGE OPTIONS - None
- HAIL GUARD - None

Minimum Unit Clearances

Walls or Obstructions for Horizontal Air Flow

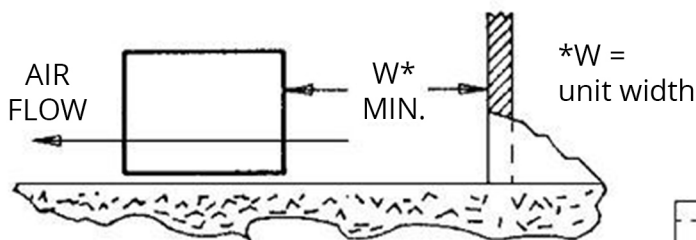

Multiple Units with Horizontal Air Flow

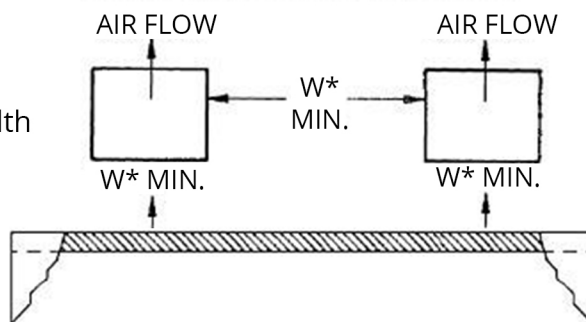

Notes

* Capacities shown are Application Capacities reflecting nominal operation at 10°F TD. For models within the scope of the DOE AWEF (Annual Walk-in Energy Factor) standard, the Net Capacity is determined by the AHRI 1250 test method. DOE will publish this compliance data at www.regulations.doe.gov

*Only refrigerants in compliance with New York state regulations can be used in the state of New York.



BEL0080BS6EEAB0200 - SUBMITTAL

Project Name:	-	Project Location:	-
Quote ID:	-	Item #:	2000
Submitted For:	-	Submitted On:	-
Submitted By:	-	Submitted From:	-
Identity #:	-	Tag:	-

 For Record

 For Approval

By: _____

Date: _____

General Product Information

Product Family:	BEL	Motor type	EC
Defrost Type:	Electric	Number of Fans:	2
Voltage: (Volts/Ph/Hz)	208-230/1/60	Fan HorsePower	1/20
Refrigerant Type:	R448A	Fins per Inch	6

Technical Information

Performance Data

Capacity			Air Flow				Altitude (ft)	AWEF Value	
TD (°F)	SST (°F)	Application Capacity* (BTU/H)	CFM	Fan Diameter (in.)	Air Throw (ft)			Cooler > 32	Freezer <= 32
				Standard		w/Collar			
10	-20	8,400	1371	12	-	-	0	N/A	4

Electrical Data

Fan Motor(s)		Defrost Heater(s)		Drain pan Heater(s) HG	
Watts	Amps	Watts	Amps	Watts	Amps
118	1	2100	9.1	-	-

Unit Specifications

Connections (in.)						Approx. Net Weight (lbs)
Coil Inlet	Suction	External Equalizer	Drain	Side Port	Hot Gas Drain Pan	
1/2	5/8	1/4	3/4	-	-	54

Dimensional Drawing(s)

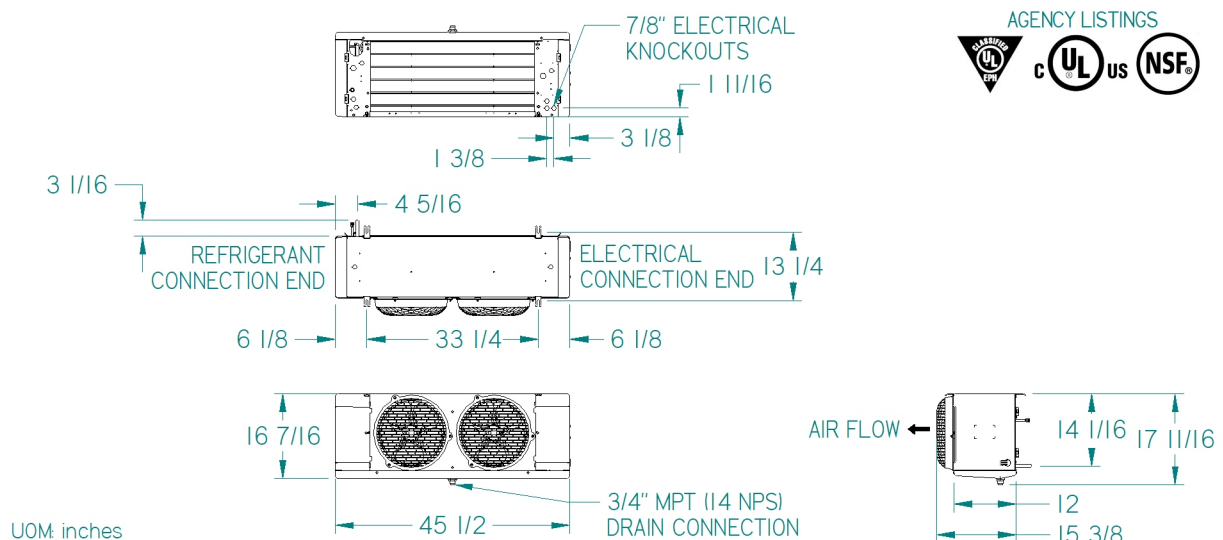



Project Name:	-	Project Location:	-
Quote ID:	-	Item #:	2000
Submitted For:	-	Submitted On:	-
Submitted By:	-	Submitted From:	-
Identity #:	-	Tag:	-

Standard Features

EASE OF INSTALLATION SERVICE

- ALL ELECTRICAL COMPONENTS FACTORY WIRED TO TERMINAL BOARD AND IDENTIFIED, MAKING IT EASY TO FIELD WIRE THE UNIT
- CABINET DESIGN FEATURES HINGED, REMOVABLE FRONT ACCESS PANELS ON EACH SIDE FOR EASY ACCESS TO ELECTRICAL AND REFRIGERATION COMPONENTS
- LIQUID LINE SOLENOID WIRE HARNESS IS FACTORY-INSTALLED FOR QUICK INSTALLATION
- MOTORS PLUG INTO WIRING HARNESS FOR EASIER SERVICING
- HINGED, REMOVABLE DRAIN PAN FOR EASY AND SAFE ACCESS
- PRE-DRILLED HOLES ON THE BACK OF THE UNIT FOR ROOM THERMOSTAT
- QUICK REMOVAL FAN GUARD/MOTOR ASSEMBLY FOR EASY SERVICE OR REPLACEMENT OF AIR MOVER PARTS

RELIABLE DURABLE

- HEAVY GAUGE GRAINED ALUMINUM CABINET CLEANS EASILY AND LOOKS ATTRACTIVE
- MOLDED FAN GUARD AND ACCESS PANELS ARE MADE OF STRONG, DURABLE, AND NSF AND UL SANITATION RATED PLASTIC MATERIAL
- SWEAT CONNECTIONS TO REDUCE POTENTIAL FOR LEAKS

PERFORMANCE

- INTERNAL PANELS ARE ISOLATED FOR QUIET OPERATION
- INTERNALLY ENHANCED TUBING AND FIN DESIGN FOR HIGHER EFFICIENCY
- EC MOTORS STANDARD ON ALL MODELS FOR IMPROVED UNIT EFFICIENCY

VERSATILE

- LARGE DIAMETER DRAIN HOLE (3/4 " ID) IS LOCATED TOWARDS THE BACK OF THE UNIT
- MINIMAL HEIGHT OF THE LOW PROFILE SERIES MAKES IT IDEAL FOR LOW CEILING COOLERS

Options

Mounted Options

- Cabinet Type - Stucco
- Controller Option - Intelligen
- Drain Pan Type - Stucco
- Fan Blade - Standard
- Coil Fin Material - Aluminium
- UC Solenoid Voltage - None
- Nozzle PartNumber - L-1
- Coil Mechanical Option - Intelligen
- Drain Pan Defrost Type - Electric
- DTFD Option - None
- Fan Guard - Molded
- Hot Gas External Piping - None
- Valve Part Number - E2V24BWAE0

Minimum Unit Clearances

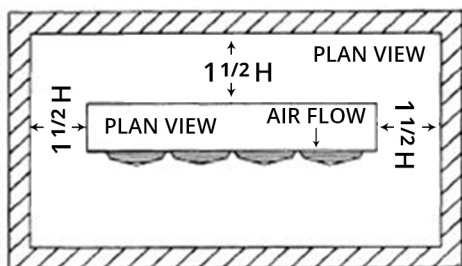

One Evaporator

NOTE:
H = Total Height
evaporator
coil surface.

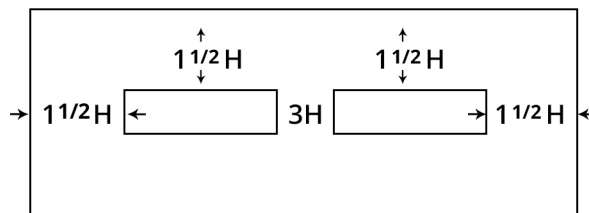

Two Evaporators

Notes

* Capacities shown are Application Capacities reflecting nominal operation at 10°F TD. For models within the scope of the DOE AWEF (Annual Walk-in Energy Factor) standard, the Net Capacity is determined by the AHRI 1250 test method. DOE will publish this compliance data at www.regulations.doe.gov



Project Name:	-	Project Location:	-
Quote ID:	-	Item #:	3000
Submitted For:	-	Submitted On:	-
Submitted By:	-	Submitted From:	-
Identity #:	-	Tag:	-

 For Record

 For Approval

By: _____

Date: _____

General Product Information

Product Family:	HTS	Compressor Brand:	Copeland
Application:	Outdoor	Compressor Type:	Scroll
Temperature Range:	Medium Temp	Compressor Hp:	1.5
Voltage: (Volts/Ph/Hz)	208-230/1/60	Compressor Model:	ZS13KAE-PFV-118
Refrigerant Type:	R404A	Number of Compressor(s):	1
Piping:	Standard	Coil Type:	Microchannel

Note : This equipment meets the regulatory requirements for hydrofluorocarbons as of the manufacturing date. Only those refrigerants approved in the state for specific end uses may be used.

Technical Information

Performance Data

Ambient Temperature (°F)	Saturated Suction Temperature (°F)	Application Capacity* (BTU/H)	Altitude (ft)	AWEF Value
95	25	17,540	0	7.6

Electrical Data

Compressor(s)		Fan Motor(s)			Electric Ratings						
RLA	LRA	Quantity	Hp	FLA	Defrost Type	High or Low Amps?	Number of Contactors	MCA	MOPD	Evap. Fan Amps	Defrost Heater Amps
10.8	56	2	1/15	1	AIR DEFROST	-	-	15	25	-	-

Unit Specifications

Connections (in.)		Receiver 90% Full (lbs)		Fan Blade(s) Diameter (in)	Sound Data (dB)	Approx. Net Weight (lbs)
Liquid Line	Suction	Standard	Over Sized			
0.5	0.875	14	20	14	63	230

Dimensional Drawing(s)

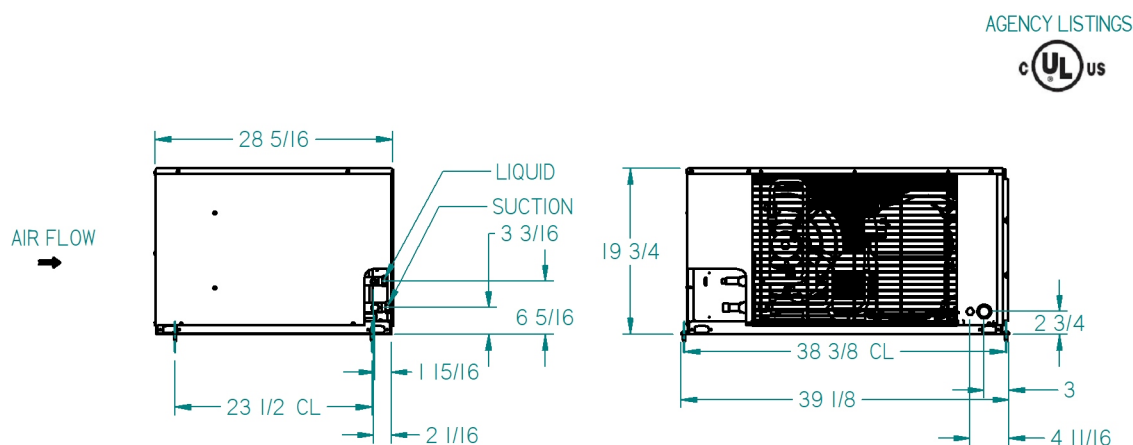

UOM: inches



Project Name:	-	Project Location:	-
Quote ID:	-	Item #:	3000
Submitted For:	-	Submitted On:	-
Submitted By:	-	Submitted From:	-
Identity #:	-	Tag:	-

Standard Features

CABINET AND CONSTRUCTION

- MICROCHANNEL COIL TECHNOLOGY STANDARD ON ALL UNITS
- PAINTED STEEL CABINETS FOR SUPERIOR STRENGTH AND CORROSION PROTECTION
- HEAVY DUTY, STEEL, 1-1/2" TALL BASE

QUALITY

- ALL UNITS ARE COMPLETELY LEAK TESTED IN A HELIUM ENVIRONMENT, BUMP TESTED AND ALLOWED TO CYCLE OFF ON THE HIGH AND LOW PRESSURE CONTROL. EACH UNIT HAS A COPY OF THE RUN DATA SHIPPED INSIDE THE ELECTRICAL PANEL
- ELECTRICAL CIRCUITS ARE COMPLETELY CHECKED FOR CONTINUITY
- PIPING IS LAID OUT TO MINIMIZE STRESS AND VIBRATION AND IS PRE-BENT TO ELIMINATE LEAKS
- ENCAPSULATED, AUTO-RESET, HIGH AND LOW PRESSURE CONTROLS TO ELIMINATE LEAKS (ADJUSTABLE LOW PRESSURE CONTROL STANDARD)

SERVICEABILITY

- SUCTION SERVICE VALVES FOR HERMETIC AND SCROLL COMPRESSORS LOCATED OUTSIDE THE CABINET FOR QUICK INSTALLATIONS.
- RECEIVER WITH FUSIBLE PLUG, LIQUID SHUTOFF VALVE AND CHARGING PORT IS STANDARD
- LARGE ELECTRICAL PANEL FOR EASE OF ACCESS
- PREFABRICATED WIRING HARNESSSES FOR TIGHT CRIMP CONNECTIONS AND CONSISTENT LABELING
- UNIT STAYS ON IF THE HOOD IS REMOVED FOR SERVICING
- SIGHT GLASS IS EASILY VIEWABLE

Options

Mounted Options

- BRAND LABEL OPTION - BOHN
- Pressure Options - ADJUSTABLE LOW - FIXED HIGH
- Crankcase Heater - CRANKCASE HEATER
- Fused Disconnect - NO FUSED DISCONNECT
- Coil Selection - MICROCHANNEL COIL
- Liquid Line Options - FILTER DRIER AND SIGHT GLASS
- Discharge Line Options - HEAD PRESSURE VALVE 150#
- BASE LEG BRACKET OPTIONS - None
- COMPLIANCE - DOE COMPLIANT
- Defrost Timer Options - NO TIMER
- Motor - PSC
- Phase Loss Monitor - NONE
- Cabinet Selection - Painted
- Receiver Options - STANDARD
- Suction Line Options - SUCTION TUBE ONLY
- PRE-CHARGE OPTIONS - None
- HAIL GUARD - None

Minimum Unit Clearances

Walls or Obstructions for Horizontal Air Flow

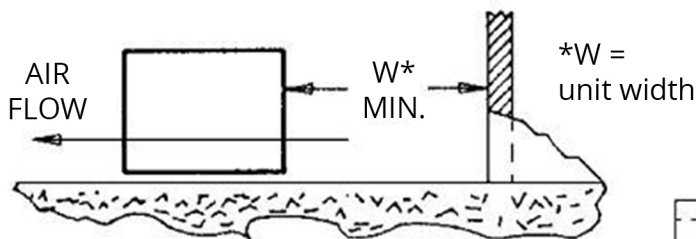

Multiple Units with Horizontal Air Flow

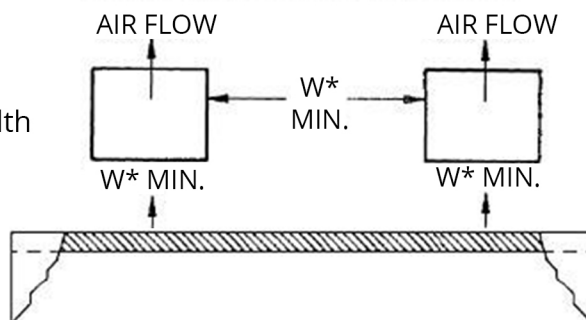

Notes

* Capacities shown are Application Capacities reflecting nominal operation at 10°F TD. For models within the scope of the DOE AWEF (Annual Walk-in Energy Factor) standard, the Net Capacity is determined by the AHRI 1250 test method. DOE will publish this compliance data at www.regulations.doe.gov

*Only refrigerants in compliance with New York state regulations can be used in the state of New York.



BEL0060AS6AMAB0200 - SUBMITTAL

Project Name:	-	Project Location:	-
Quote ID:	-	Item #:	4000
Submitted For:	-	Submitted On:	-
Submitted By:	-	Submitted From:	-
Identity #:	-	Tag:	-

 For Record

 For Approval

By: _____

Date: _____

General Product Information

Product Family:	BEL	Motor type	2 SPEED EC
Defrost Type:	Air	Number of Fans:	1
Voltage: (Volts/Ph/Hz)	115/1/60	Fan HorsePower	1/20
Refrigerant Type:	R448A	Fins per Inch	6

Technical Information

Performance Data

Capacity			Air Flow				Altitude (ft)	AWEF Value	
TD (°F)	SST (°F)	Application Capacity* (BTU/H)	CFM	Fan Diameter (in.)	Air Throw (ft)			Cooler > 32	Freezer <= 32
					Standard	w/Collar			
10	25	7,800	610	12	-	-	0	9	N/A

Electrical Data

Fan Motor(s)		Defrost Heater(s)		Drain pan Heater(s) HG	
Watts	Amps	Watts	Amps	Watts	Amps
55	0.85	-	-	-	-

Unit Specifications

Connections (in.)						Approx. Net Weight (lbs)
Coil Inlet	Suction	External Equalizer	Drain	Side Port	Hot Gas Drain Pan	
1/2	5/8	1/4	3/4	-	-	36

Dimensional Drawing(s)

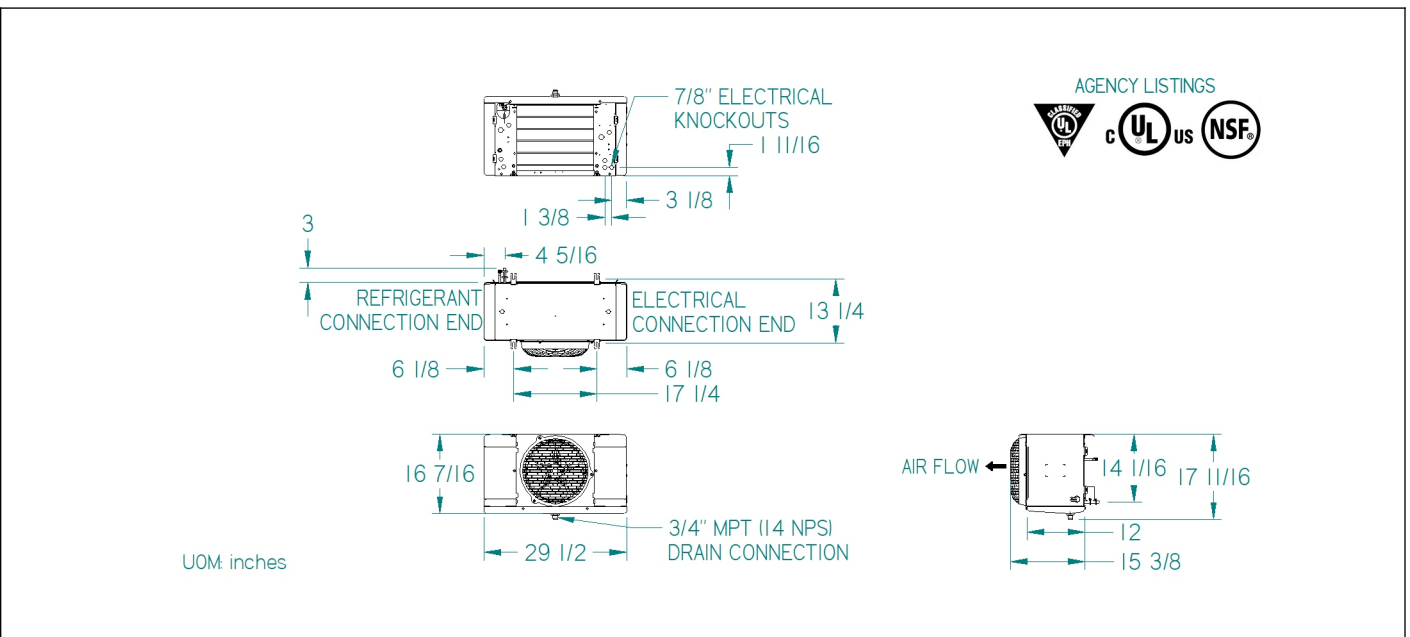

Project Name:	-	Project Location:	-
Quote ID:	-	Item #:	4000
Submitted For:	-	Submitted On:	-
Submitted By:	-	Submitted From:	-
Identity #:	-	Tag:	-

Standard Features

EASE OF INSTALLATION SERVICE

- ALL ELECTRICAL COMPONENTS FACTORY WIRED TO TERMINAL BOARD AND IDENTIFIED, MAKING IT EASY TO FIELD WIRE THE UNIT
- CABINET DESIGN FEATURES HINGED, REMOVABLE FRONT ACCESS PANELS ON EACH SIDE FOR EASY ACCESS TO ELECTRICAL AND REFRIGERATION COMPONENTS
- LIQUID LINE SOLENOID WIRE HARNESS IS FACTORY-INSTALLED FOR QUICK INSTALLATION
- MOTORS PLUG INTO WIRING HARNESS FOR EASIER SERVICING
- HINGED, REMOVABLE DRAIN PAN FOR EASY AND SAFE ACCESS
- PRE-DRILLED HOLES ON THE BACK OF THE UNIT FOR ROOM THERMOSTAT
- QUICK REMOVAL FAN GUARD/MOTOR ASSEMBLY FOR EASY SERVICE OR REPLACEMENT OF AIR MOVER PARTS

RELIABLE DURABLE

- HEAVY GAUGE GRAINED ALUMINUM CABINET CLEANS EASILY AND LOOKS ATTRACTIVE
- MOLDED FAN GUARD AND ACCESS PANELS ARE MADE OF STRONG, DURABLE, AND NSF AND UL SANITATION RATED PLASTIC MATERIAL
- SWEAT CONNECTIONS TO REDUCE POTENTIAL FOR LEAKS

PERFORMANCE

- INTERNAL PANELS ARE ISOLATED FOR QUIET OPERATION
- INTERNALLY ENHANCED TUBING AND FIN DESIGN FOR HIGHER EFFICIENCY
- EC MOTORS STANDARD ON ALL MODELS FOR IMPROVED UNIT EFFICIENCY

VERSATILE

- LARGE DIAMETER DRAIN HOLE (3/4" ID) IS LOCATED TOWARDS THE BACK OF THE UNIT
- MINIMAL HEIGHT OF THE LOW PROFILE SERIES MAKES IT IDEAL FOR LOW CEILING COOLERS

Options

Mounted Options

- Cabinet Type - Stucco
- Controller Option - Intelligen
- Drain Pan Type - Stucco
- Fan Blade - Standard
- Coil Fin Material - Aluminium
- UC Solenoid Voltage - None
- Nozzle PartNumber - L-1/2
- Coil Mechanical Option - Intelligen
- Drain Pan Defrost Type - None
- DTFD Option - None
- Fan Guard - Molded
- Hot Gas External Piping - None
- Valve Part Number - E2V24BWAE0

Minimum Unit Clearances

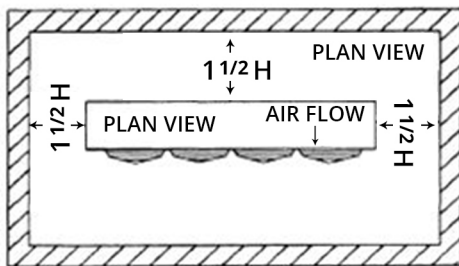

One Evaporator

NOTE:
H = Total Height evaporator coil surface.

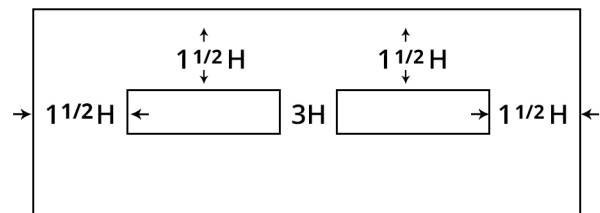

Two Evaporators

Notes

* Capacities shown are Application Capacities reflecting nominal operation at 10°F TD. For models within the scope of the DOE AWEF (Annual Walk-in Energy Factor) standard, the Net Capacity is determined by the AHRI 1250 test method. DOE will publish this compliance data at www.regulations.doe.gov



Project Name:	-	Project Location:	-
Quote ID:	-	Item #:	1000
Submitted For:	-	Submitted On:	-
Submitted By:	-	Submitted From:	-
Identity #:	-	Tag:	-

 For Record

 For Approval

By: _____

Date: _____

General Product Information

Product Family:	HTS	Compressor Brand:	Copeland
Application:	Outdoor	Compressor Type:	Scroll
Temperature Range:	Medium Temp	Compressor Hp:	1
Voltage: (Volts/Ph/Hz)	208-230/1/60	Compressor Model:	ZS09KAE-PFV-118
Refrigerant Type:	R448A	Number of Compressor(s):	1
Piping:	Standard	Coil Type:	Microchannel

Technical Information

Performance Data

Ambient Temperature (°F)	Saturated Suction Temperature (°F)	Application Capacity* (BTU/H)	Altitude (ft)	AWEF Value
95	25	9,700	0	7.6

Electrical Data

Compressor(s)		Fan Motor(s)			Electric Ratings						
RLA	LRA	Quantity	Hp	FLA	Defrost Type	High or Low Amps?	Number of Contactors	MCA	MOPD	Evap. Fan Amps	Defrost Heater Amps
9	40	1	1/15	0.5	AIR DEFROST	-	-	15	20	-	-

Unit Specifications

Connections (in.)		Receiver 90% Full (lbs)		Fan Blade(s) Diameter (in)	Sound Data (dB)	Approx. Net Weight (lbs)
Liquid Line	Suction	Standard	Over Sized			
0.375	0.625	9	-	14	61	184

Dimensional Drawing(s)

AGENCY LISTINGS

UOM: inches



Project Name:	-	Project Location:	-
Quote ID:	-	Item #:	1000
Submitted For:	-	Submitted On:	-
Submitted By:	-	Submitted From:	-
Identity #:	-	Tag:	-

Standard Features

CABINET AND CONSTRUCTION

- MICROCHANNEL COIL TECHNOLOGY STANDARD ON ALL UNITS
- PAINTED STEEL CABINETS FOR SUPERIOR STRENGTH AND CORROSION PROTECTION
- HEAVY DUTY, STEEL, 1-1/2" TALL BASE

SERVICEABILITY

- SUCTION SERVICE VALVES FOR HERMETIC AND SCROLL COMPRESSORS LOCATED OUTSIDE THE CABINET FOR QUICK INSTALLATIONS.
- RECEIVER WITH FUSIBLE PLUG, LIQUID SHUTOFF VALVE AND CHARGING PORT IS STANDARD
- LARGE ELECTRICAL PANEL FOR EASE OF ACCESS
- PREFABRICATED WIRING HARNESSSES FOR TIGHT CRIMP CONNECTIONS AND CONSISTENT LABELING
- UNIT STAYS ON IF THE HOOD IS REMOVED FOR SERVICING
- SIGHT GLASS IS EASILY VIEWABLE

QUALITY

- ALL UNITS ARE COMPLETELY LEAK TESTED IN A HELIUM ENVIRONMENT, BUMP TESTED AND ALLOWED TO CYCLE OFF ON THE HIGH AND LOW PRESSURE CONTROL. EACH UNIT HAS A COPY OF THE RUN DATA SHIPPED INSIDE THE ELECTRICAL PANEL
- ELECTRICAL CIRCUITS ARE COMPLETELY CHECKED FOR CONTINUITY
- PIPING IS LAID OUT TO MINIMIZE STRESS AND VIBRATION AND IS PRE-BENT TO ELIMINATE LEAKS
- ENCAPSULATED, AUTO-RESET, HIGH AND LOW PRESSURE CONTROLS TO ELIMINATE LEAKS (ADJUSTABLE LOW PRESSURE CONTROL STANDARD)

Options

Mounted Options

- BRAND LABEL OPTION - BOHN
- Pressure Options - ADJUSTABLE LOW - FIXED HIGH
- Crankcase Heater - CRANKCASE HEATER
- Fused Disconnect - NO FUSED DISCONNECT
- Coil Selection - MICROCHANNEL COIL
- Liquid Line Options - FILTER DRIER AND SIGHT GLASS
- Discharge Line Options - HEAD PRESSURE VALVE 150#
- BASE LEG BRACKET OPTIONS - None
- COMPLIANCE - DOE COMPLIANT
- Defrost Timer Options - NO TIMER
- Motor - FIXED SPEED EC
- Phase Loss Monitor - NONE
- Cabinet Selection - Painted
- Receiver Options - STANDARD
- Suction Line Options - SUCTION TUBE ONLY
- PRE-CHARGE OPTIONS - None
- HAIL GUARD - None

Minimum Unit Clearances

Walls or Obstructions for Horizontal Air Flow

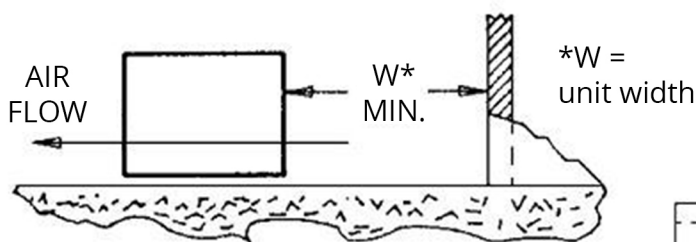

Multiple Units with Horizontal Air Flow

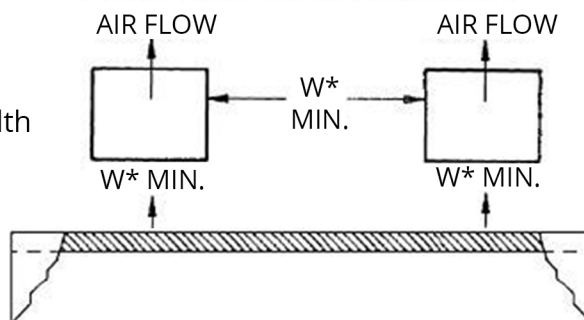

Notes

* Capacities shown are Application Capacities reflecting nominal operation at 10°F TD. For models within the scope of the DOE AWEF (Annual Walk-in Energy Factor) standard, the Net Capacity is determined by the AHRI 1250 test method. DOE will publish this compliance data at www.regulations.doe.gov

*Only refrigerants in compliance with New York state regulations can be used in the state of New York.



BEL0095AS6AMAB0200 - SUBMITTAL

Project Name:	-	Project Location:	-
Quote ID:	-	Item #:	2000
Submitted For:	-	Submitted On:	-
Submitted By:	-	Submitted From:	-
Identity #:	-	Tag:	-

 For Record

 For Approval

By: _____

Date: _____

General Product Information

Product Family:	BEL	Motor type	2 SPEED EC
Defrost Type:	Air	Number of Fans:	2
Voltage: (Volts/Ph/Hz)	115/1/60	Fan HorsePower	1/20
Refrigerant Type:	R448A	Fins per Inch	6

Technical Information

Performance Data

Capacity			Air Flow				Altitude (ft)	AWEF Value	
TD (°F)	SST (°F)	Application Capacity* (BTU/H)	CFM	Fan Diameter (in.)	Air Throw (ft)			Cooler > 32	Freezer <= 32
				Standard	w/Collar				
10	25	10,000	1305	12	20	-	0	9	N/A

Electrical Data

Fan Motor(s)		Defrost Heater(s)		Drain pan Heater(s) HG	
Watts	Amps	Watts	Amps	Watts	Amps
110	1.8	-	-	-	-

Unit Specifications

Connections (in.)						Approx. Net Weight (lbs)
Coil Inlet	Suction	External Equalizer	Drain	Side Port	Hot Gas Drain Pan	
1/2	5/8	1/4	3/4	-	-	51

Dimensional Drawing(s)

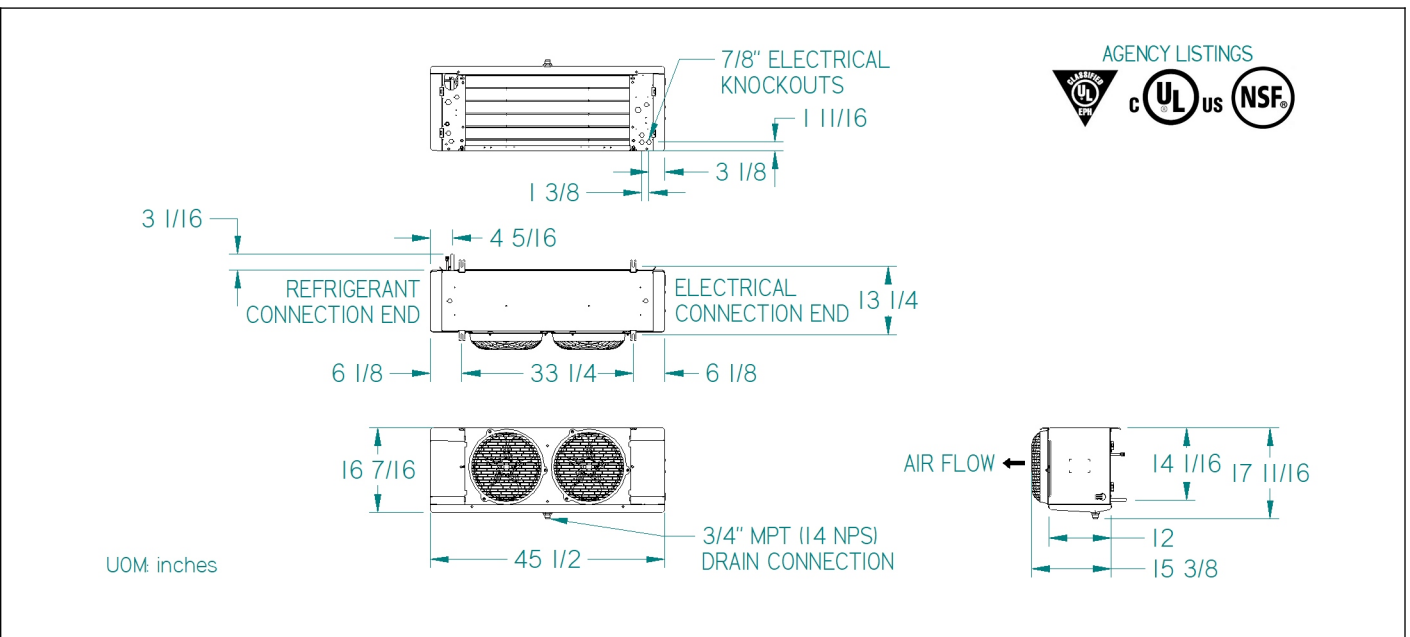

Project Name:	-	Project Location:	-
Quote ID:	-	Item #:	2000
Submitted For:	-	Submitted On:	-
Submitted By:	-	Submitted From:	-
Identity #:	-	Tag:	-

Standard Features

EASE OF INSTALLATION SERVICE

- ALL ELECTRICAL COMPONENTS FACTORY WIRED TO TERMINAL BOARD AND IDENTIFIED, MAKING IT EASY TO FIELD WIRE THE UNIT
- CABINET DESIGN FEATURES HINGED, REMOVABLE FRONT ACCESS PANELS ON EACH SIDE FOR EASY ACCESS TO ELECTRICAL AND REFRIGERATION COMPONENTS
- LIQUID LINE SOLENOID WIRE HARNESS IS FACTORY-INSTALLED FOR QUICK INSTALLATION
- MOTORS PLUG INTO WIRING HARNESS FOR EASIER SERVICING
- HINGED, REMOVABLE DRAIN PAN FOR EASY AND SAFE ACCESS
- PRE-DRILLED HOLES ON THE BACK OF THE UNIT FOR ROOM THERMOSTAT
- QUICK REMOVAL FAN GUARD/MOTOR ASSEMBLY FOR EASY SERVICE OR REPLACEMENT OF AIR MOVER PARTS

RELIABLE DURABLE

- HEAVY GAUGE GRAINED ALUMINUM CABINET CLEANS EASILY AND LOOKS ATTRACTIVE
- MOLDED FAN GUARD AND ACCESS PANELS ARE MADE OF STRONG, DURABLE, AND NSF AND UL SANITATION RATED PLASTIC MATERIAL
- SWEAT CONNECTIONS TO REDUCE POTENTIAL FOR LEAKS

PERFORMANCE

- INTERNAL PANELS ARE ISOLATED FOR QUIET OPERATION
- INTERNALLY ENHANCED TUBING AND FIN DESIGN FOR HIGHER EFFICIENCY
- EC MOTORS STANDARD ON ALL MODELS FOR IMPROVED UNIT EFFICIENCY

VERSATILE

- LARGE DIAMETER DRAIN HOLE (3/4" ID) IS LOCATED TOWARDS THE BACK OF THE UNIT
- MINIMAL HEIGHT OF THE LOW PROFILE SERIES MAKES IT IDEAL FOR LOW CEILING COOLERS

Options

Mounted Options

- Cabinet Type - Stucco
- Controller Option - Intelligen
- Drain Pan Type - Stucco
- Fan Blade - Standard
- Coil Fin Material - Aluminium
- UC Solenoid Voltage - None
- Nozzle PartNumber - L-3/4
- Coil Mechanical Option - Intelligen
- Drain Pan Defrost Type - None
- DTFD Option - None
- Fan Guard - Molded
- Hot Gas External Piping - None
- Valve Part Number - E2V24BWAE0

Minimum Unit Clearances

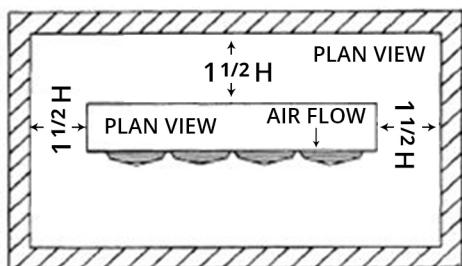

One Evaporator

NOTE:
H = Total Height evaporator coil surface.

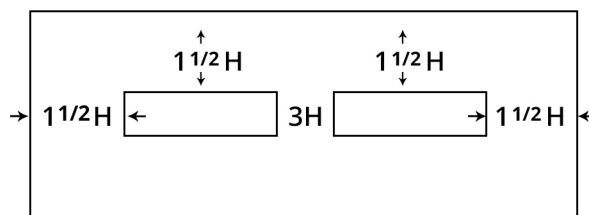

Two Evaporators

Notes

* Capacities shown are Application Capacities reflecting nominal operation at 10°F TD. For models within the scope of the DOE AWEF (Annual Walk-in Energy Factor) standard, the Net Capacity is determined by the AHRI 1250 test method. DOE will publish this compliance data at www.regulations.doe.gov

WALK-IN SPECIFICATIONS

General

Walk-in coolers and freezers shall be prefabricated of modular design and construction. They shall be designed and constructed to allow fast and easy field assembly, disassembly and enlargement by the addition of panels.

Panel Fabrication

Standard wall, ceiling and floor panels shall be fabricated in 47" and 23" in width and shall be interchangeable with like panels. Partition and other panels placement shall be within 1/2" increments to meet job site conditions. Indoor walk-in maximum panel height and ceiling length is 21 feet.

Available standard height with floor panels: 6'-6", 7'-7", 8'-7". Available standard height without floor panels with NSF vinyl screed: 6'-2", 7'-2", 7'-7", 8'-2". Panels shall consist of Extruded Polystyrene (XPS) rigid foam insulation, bonded permanently to interior and exterior metal "skin". Tongue and groove edges of panels shall be of the same panel core insulation with non-corrosive thermoplastic cam-action panel fastener. NSF approved compression gasket shall be applied to the tongue side of all panels on both interior and exterior.

Floor Construction

Floor panels: Shall be fabricated similar to other panels and shall be designed to withstand uniformly distributed load of 700 lbs per square foot, suitable for foot traffic. Available 1000, 1300, 1600 lbs per square foot suitable for light rolling cart traffic. The ULTIMATE floor with load bearing capacity of 2,750 lbs per square foot is suitable for hand pallet jack application.

Floorless: Provided with NSF vinyl screeds. Screed will be coved with 1/2" radius, designed to sit flat on a finished tile/concrete floor. Screed shall be lag fastened to floor.

Insulation

Insulation shall be 4" thick, rigid Extruded Polystyrene (XPS) foam closed cell, void free, Hydrophobic as tested in accordance to ASTM C272. UL Class 1 classified as per ASTM E84/UL-723. Core material has a flame spread of 15 or less and a smoke developed of 165 or less. Self ignition temperature rating at 896 degree Fahrenheit and flash ignition temperature rating at 734 degree Fahrenheit as tested in accordance with ASTM D 1929.

Thermal resistance: For Coolers R-29 (reported at 55 F mean temperature). For freezer R-32 (reported at 20 F mean temperature). Standard with a 50 year R-value warranty.



Entrance Door

Each walk-in shall be fitted with one 36" x 76" swing-type entrance door. Door shall be flush type, bearing the NSF and UL seal of approved. Door shall be equipped with two adjustable spring-assisted hinges, deadbolt key/padlock handle with safety inside release, magnetic gasket, door closer, and a double sweep wiper at the bottom edge of door. Door jamb shall be provided with a LED light fixture center mounted, digital thermometer with safety pilot light on-off switch and conduit between switch box and outlet junction box.

Freezer door includes a heater cable with heat sensing regulating thermostat and a heated air pressure relief vent.

Metal Finish

Wall & Ceiling Panel: Standard Acrylume[®] 26 gauge (acrylic coated galvalume) stucco embossed on the interior and exterior wall, ceiling and exterior of floor panels.

Floor Panel: Standard interior floor panels shall be 22 gauge smooth stainless steel type 304, 2B and optional 20 gauge textured/rigidized stainless steel type 304, 2B.

Refrigeration

Heatcraft Worldwide BOHN refrigeration (preferred vendor). Condensing units and evaporators shall be factory pre-wired and pre-assembled. New 1/2HP to 6HP air cooled condensing unit with exclusive HYPERCORE microchannel coil technology that uses less refrigerant, saves energy, reduces operational cost, improves durability and system performance.

Approvals

- National Sanitation Foundation (NSF), Standard No. 7
- Underwriters Laboratories (UL) certified, ASTM E84/UL-723
- Department of Energy (DOE) compliant
- City of Houston Fabrication Certificate No. 694
- Oregon State Component Insignia Compliance No. M-PFC 688
- New York City approval MEA113-87-M
- Miami-Dade County, Outdoor Hurricane High Velocity Wind (175 mph) NOA #17-0802.12
- State of Florida, Outdoor Hurricane High Velocity Wind (175 mph) #FL 22413



Foamed In-Place Vs. Extruded Polystyrene

Foamed-in-place Urethane Insulation Consistently Inconsistent

9/4/2017

Recently, urethane panel insulation has come under fire for numerous inherited quality issues. It may be time for you to consider using another type of insulation. Why? It's simple.

The injection process in which urethane panels are manufactured poses many challenges, namely the formation of the foam material and the overall inconsistency of the compound. Unfortunately, these issues go unnoticed as they take place within the cavity between two metal skins. For that reason, even within short period of time they can seriously compromise the integrity and thermal performance of the panels.

Common issues caused by the injection of foam insulation are:

- Irregularly shaped and sized cells causing air and moisture to seep into.
- Thermal drift (or the loss of R-value) caused by air and moisture inside the foam cell.
- Imprecise control of cell wall's strength causes many cells to collapse and therefore foam to rapidly deteriorate.
- Lack of a strong/permanent bond to metal skins can lead to delamination.
- Different R-values throughout the panel due to varying foam density, voids and empty pockets.
- Compromised the short and long term panel thermal performance.

Many customers have experienced these issues and have made the switch to walk-in coolers and freezers insulated with Extruded Polystyrene (XPS) rigid foam. For over 70 years, XPS has shown to hold R-value over time without the many inconsistencies of the urethane foam.

AmeriKooler uses only high-performance AK-XPS4 Extruded Polystyrene foam insulation from The DOW Chemical that is backed by the 50 Year R-value warranty. AK-XPS4 insulation outstanding attributes will contribute to higher walk-in performance, increase longevity of the refrigeration unit and lower energy cost to the owner.

WALK-IN SPECIFICATIONS

General

Walk-in coolers and freezers shall be prefabricated of modular design and construction. They shall be designed and constructed to allow fast and easy field assembly, disassembly and enlargement by the addition of panels.

Panel Fabrication

Standard wall, ceiling and floor panels shall be fabricated in 47" and 23" in width and shall be interchangeable with like panels. Partition and other panels placement shall be within 1/2" increments to meet job site conditions. Indoor walk-in maximum panel height and ceiling length is 21 feet.

Available standard height with floor panels: 6'-6", 7'-7", 8'-7". Available standard height without floor panels with NSF vinyl screed: 6'-2", 7'-2", 7'-7", 8'-2". Panels shall consist of Extruded Polystyrene (XPS) rigid foam insulation, bonded permanently to interior and exterior metal "skin". Tongue and groove edges of panels shall be of the same panel core insulation with non-corrosive thermoplastic cam-action panel fastener. NSF approved compression gasket shall be applied to the tongue side of all panels on both interior and exterior.

Floor Construction

Floor panels: Shall be fabricated similar to other panels and shall be designed to withstand uniformly distributed load of 700 lbs per square foot, suitable for foot traffic. Available 1000, 1300, 1600 lbs per square foot suitable for light rolling cart traffic. The ULTIMATE floor with load bearing capacity of 2,750 lbs per square foot is suitable for hand pallet jack application.

Floorless: Provided with NSF vinyl screeds. Screed will be coved with 1/2" radius, designed to sit flat on a finished tile/concrete floor. Screed shall be lag fastened to floor.

Insulation

Insulation shall be 4" thick, rigid Extruded Polystyrene (XPS) foam closed cell, void free, Hydrophobic as tested in accordance to ASTM C272. UL Class 1 classified as per ASTM E84/UL-723. Core material has a flame spread of 15 or less and a smoke developed of 165 or less. Self ignition temperature rating at 896 degree Fahrenheit and flash ignition temperature rating at 734 degree Fahrenheit as tested in accordance with ASTM D 1929.

Thermal resistance: For Coolers R-29 (reported at 55 F mean temperature). For freezer R-32 (reported at 20 F mean temperature). Standard with a 50 year R-value warranty.



Entrance Door

Each walk-in shall be fitted with one 36" x 76" swing-type entrance door. Door shall be flush type, bearing the NSF and UL seal of approved. Door shall be equipped with two adjustable spring-assisted hinges, deadbolt key/padlock handle with safety inside release, magnetic gasket, door closer, and a double sweep wiper at the bottom edge of door. Door jamb shall be provided with a LED light fixture center mounted, digital thermometer with safety pilot light on-off switch and conduit between switch box and outlet junction box.

Freezer door includes a heater cable with heat sensing regulating thermostat and a heated air pressure relief vent.

Metal Finish

Wall & Ceiling Panel: Standard Acrylume[®] 26 gauge (acrylic coated galvalume) stucco embossed on the interior and exterior wall, ceiling and exterior of floor panels.

Floor Panel: Standard interior floor panels shall be 22 gauge smooth stainless steel type 304, 2B and optional 20 gauge textured/rigidized stainless steel type 304, 2B.

Refrigeration

Heatcraft Worldwide BOHN refrigeration (preferred vendor). Condensing units and evaporators shall be factory pre-wired and pre-assembled. New 1/2HP to 6HP air cooled condensing unit with exclusive HYPERCORE microchannel coil technology that uses less refrigerant, saves energy, reduces operational cost, improves durability and system performance.

Approvals

- National Sanitation Foundation (NSF), Standard No. 7
- Underwriters Laboratories (UL) certified, ASTM E84/UL-723
- Department of Energy (DOE) compliant
- City of Houston Fabrication Certificate No. 694
- Oregon State Component Insignia Compliance No. M-PFC 688
- New York City approval MEA113-87-M
- Miami-Dade County, Outdoor Hurricane High Velocity Wind (175 mph) NOA #17-0802.12
- State of Florida, Outdoor Hurricane High Velocity Wind (175 mph) #FL 22413



Foamed In-Place Vs. Extruded Polystyrene

Foamed-in-place Urethane Insulation Consistently Inconsistent

9/4/2017

Recently, urethane panel insulation has come under fire for numerous inherited quality issues. It may be time for you to consider using another type of insulation. Why? It's simple.

The injection process in which urethane panels are manufactured poses many challenges, namely the formation of the foam material and the overall inconsistency of the compound. Unfortunately, these issues go unnoticed as they take place within the cavity between two metal skins. For that reason, even within short period of time they can seriously compromise the integrity and thermal performance of the panels.

Common issues caused by the injection of foam insulation are:

- Irregularly shaped and sized cells causing air and moisture to seep into.
- Thermal drift (or the loss of R-value) caused by air and moisture inside the foam cell.
- Imprecise control of cell wall's strength causes many cells to collapse and therefore foam to rapidly deteriorate.
- Lack of a strong/permanent bond to metal skins can lead to delamination.
- Different R-values throughout the panel due to varying foam density, voids and empty pockets.
- Compromised the short and long term panel thermal performance.

Many customers have experienced these issues and have made the switch to walk-in coolers and freezers insulated with Extruded Polystyrene (XPS) rigid foam. For over 70 years, XPS has shown to hold R-value over time without the many inconsistencies of the urethane foam.

AmeriKooler uses only high-performance AK-XPS4 Extruded Polystyrene foam insulation from The DOW Chemical that is backed by the 50 Year R-value warranty. AK-XPS4 insulation outstanding attributes will contribute to higher walk-in performance, increase longevity of the refrigeration unit and lower energy cost to the owner.



Invitation for Bid 2026-051

Detention Center Freezer and Cooler Replacement

.....

ADDENDUM No. 3

ISSUE DATE: March 10, 2026

Responding Offerors on this project are hereby notified that this Addendum shall be made a part of the above named IFB document.

The following items add to, modify, and/or clarify the IFB documents and shall have the full force and effect of the original Documents. This Addendum shall be acknowledged by the Offeror in the IFB document.

Notice to Bidder

1. This Addendum is issued pursuant to the conditions of the solicitation and is hereby made part of the contract documents. The addendum serves to clarify, revise, and supersede information in the IFB. The bidder shall acknowledge receipt of this addendum in the appropriate space on the bid form. Failure to do so may subject the bidder to disqualification. A list of attachments, if any, is part of this document.

Schedule Revisions

1. The initial bid date was March 10, 2026. Union County received two (2) bid submissions before the initial deadline. Union County requires a minimum of three (3) bids to proceed with awarding the project. Therefore, a rebid date of March 25, 2026, has been set. All bids must be received by 2:00 PM EST on March 25, 2026. Late bids will not be accepted.

End of Addendum No. 3

9 APPENDIX A – BID FORM

IFB No. 2026-051 Detention Center Walk-In Freezer and Cooler Replacement

SUBMIT WITH BID

Name of Bidder: GARMON MECHANICAL SERVICE INC.

The undersigned Bidder hereby declares that he has carefully investigated the scope of work and having thoroughly familiarized himself with the Contract Documents relative hereto and has read all special provisions furnished prior to the opening of the bids; that he has satisfied himself relative to the work to be performed. The bidder further declares that he and his subcontractors have fully complied with NCGS 64, Article 2 in regard to E-Verification as required by N.C. General Statute 143-129(j). The bidder agrees to hold the proposed bid price for 90 days.

The bidder proposes and agrees if this proposal is accepted, to contract with Union County Government, in the form of contract specified, to provide all necessary labor, equipment, materials, machinery, tools, apparatus, transportation, services, fees, permits, etc., to complete the construction of Union County Detention Center Walk-In Freezer and Cooler Replacement all in accordance with the aforementioned Contract Documents to the full and entire satisfaction of Union County Government, with definite understanding that no money will be allowed for extra work except for the lump sum.

Provide 5% of the base bid price as an Owner contingency allowance and provide a Total Base Bid Price. Any funds not used from this allowance will be returned to the Owner by deduct change order.

This Bid Form must be completed in its entirety as-is and submitted with bid. The Total Bid is considered a turn-key cost for the completion of this project. *Bidder's may not write-in exceptions or additional expenses.*

Description	Estimated Days	Unit Cost	Base Bid
Trenton - M/TEZA025L8HT3DF, 2.5 HP, Low Temp Refrigeration Condensing Unit 208/230 3P.	N/A	6264. ⁰⁰	6264. ⁰⁰
Trenton - M/TPLP211LES2DR6, 2 Fan Evap., 11000 BTU, Low Temp Electric Defrost 208/230 1P.	N/A	3521. ⁰⁰	3521. ⁰⁰
Trenton - M/TEZA008H8HT3DB, .8 HP Refrigeration Condensing Unit 208/230 3P.	N/A	4422. ⁰⁰	4422. ⁰⁰
Trenton - M/TPLP209MAS1DR6, 2 Fan Evap., 9000 BTU 115 V 1P.	N/A	2715. ⁰⁰	2715. ⁰⁰
Labor	N/A		60,000. ⁰⁰
Freezer/Cooler Rental Per Day	30	233.34	7000. ⁰⁰
Other	MATERIALS		67,880. ⁰⁰
Base Bid:			151,802. ⁰⁰
5% of Base Bid =Owner's Contingency:			7,590. ¹⁰
Base Bid + Contingency = Total Bid:			159,392. ¹⁰

Provide the Following:

Manufacturer Name Trenton
Warranty (Section 6.12) 1yr all parts / extended available
NC Secretary of State ID No. 01-0556719
NC Class 1 Commercial Refrigeration License No. ~~2967~~ 2967 / 11602
NC Electrical License No. 31209-L

Bid Package Checklist:

1. Appendix A – Bid Form
2. Appendix B – Bid Submission Form (signed)
3. Appendix C – Addendum and Anti-Collusion Form (signed)
4. Freezer and Cooler Product Specifications (Section 6.14.1)
5. References (Section 6.14.2)
6. ~~Subcontractor List~~ (Section 6.14.3) NO SUBCONTRACTOR LABOR
7. Materials List (Section 6.14.4)

Time of Completion

The undersigned Bidder proposes and agrees hereby to commence the Work of the Contract Documents on a date specified in a written Notice to Proceed to be issues by Owner and shall fully complete the Work within One Hundred-Twenty Hundred [120] calendar days.

Liquidated Damages

The undersigned further agrees, stipulates, and fixes as Liquidated Damages if delayed, but not as a penalty, the sum of **Two Hundred-Fifty Dollars [\$250.00]** per calendar day that the undersigned together with the undersigned's surety shall pay the Owner for each calendar day or part thereof that expires after the date specified for the substantial completion of the work and until the Work is Substantially complete. By bidding, the undersigned hereby agrees to be responsible for liquidated damages.

Signed by an executive of the company that has authority to contract with Union County, NC.

Name: ROBERT L. GARMON JR.
Title: PRESIDENT
Signature: 
Date: 3/24/2026

10 APPENDIX B – BID SUBMISSION FORM

IFB No. 2026-051 Detention Center Walk-In Freezer and Cooler Replacement

SUBMIT WITH BID

This Bid is submitted by:

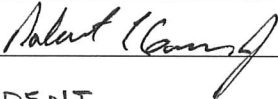
Company Legal Name: GARMON MECHANICAL SERVICE INC.
Representative Name: ROBERT L. GARMON JR.
Representative Signature: 
Representative Title: PRESIDENT
Address: PO BOX 1136
City/State/Zip: ALBEMARLE, NC 28002
Email Address: bgarmon.64@garmonmechanical.com
Phone Number: 704-984-6555
Website Address: WWW.GARMONMECHANICAL.COM

It is understood that Union County reserves the right to reject any and all Bids, to make awards according to the best interest of the County, to waive formalities, technicalities, to recover and re-bid this project. Bid is valid for 90 calendar days from the Bid due date and is submitted by an executive of the company that has authority to contract with Union County, NC.

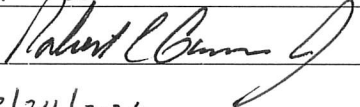
Name: ROBERT L. GARMON JR.
Title: PRESIDENT
Signature: 
Date: 3/24/2026

11 APPENDIX C – ADDENDUM AND ANTI-COLLUSION FORM

IFB No. 2026-051 Detention Center Walk-In Freezer and Cooler Replacement

SUBMIT WITH BID

Please acknowledge receipt of all addenda by including this form with your Bid. Any questions or changes received will be posted as an addendum on www.co.union.nc.us and/or www.ips.state.nc.us. It is your responsibility to check for this information.

Addendum No.	Date Downloaded
1	2/20/26
2	2/25/26
3 - REBID	3/10/26

I certify that this Bid is made in good faith and without collusion with any other offeror or officer or employee of Union County.

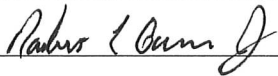
Company Name: GARMON MECHANICAL SERVICE INC.
 Name: ROBERT L. GARMON JR.
 Title: PRESIDENT
 Email Address: lgarmon.64@GARMONMECHANICAL.COM
 Signature: 
 Date: 3/24/2026



NATIONAL REFRIGERATION AND
AIR CONDITIONING CANADA CORP.

99 ROY BLVD. PO BOX 2020
BRANTFORD ON
CANADA N3T 5Y6

WHOLESALE DISTRIBUTORS
REFRIGERATION - AIR CONDITIONING
HEATING SUPPLIES & EQUIPMENT

UR UNITED REFRIGERATION INC. SYSTEMS LOAD SUMMARY

Prepared By

Prepared For

System: General Walk-in Freezer

Application Title	Location	Interior Temperature	Exterior Temperature	Internal RH	External RH	
General Walk-in Freezer	Indoor	-10 °F	85 °F	95 %	55 %	
Wall Load 0%	Infiltration Load 0%	Product Load 0%	Miscellaneous Load 0%			
Design Load	Safety Load	Run Time	Capacity Required			
SYSTEM BALANCE	SST	-19.2 °F	Evaporator TD	8.7 °F	System Capacity	9,630 BTUH



UNITED REFRIGERATION INC.



NATIONAL REFRIGERATION AND AIR CONDITIONING CANADA WHOLESALE DISTRIBUTORS GENERAL WALK-IN FREEZER
 159 ROY BLVD. PO BOX 2020 BRANTFORD ON CANADA N3T 5Y6
 REFRIGERATION - AIR CONDITIONING HEATING SUPPLIES & EQUIPMENT

Prepared By

Prepared For

COOLING REQUIREMENTS

Application Title	Location	Interior Temperature	External Temperature	Internal RH	External RH
General Walk-in Freezer	Indoor	-10 °F	85 °F	95%	55%
Wall Load 0%	Infiltration Load 0%	Product Load 0%	Miscellaneous Load 0%		
0 BTUH	0 BTUH	0 BTUH	0 BTUH		

INFILTRATION LOAD : ESTIMATED BY DOORS AND OPENINGS

Quantity	Door or Opening Type	Height (in)	Width (in)	Ext Temp (°F)	External Rh (%)	Open Time (hrs)	Curtains	Load (BTUH)
TOTAL INFILTRATION LOAD ESTIMATED BY DOORS AND OPENINGS								0

PRODUCT LOADS

Type	Weight (lb)	Enter Temp (°F)	Final Temperature (°F)	Pull Down (hrs)	Load (BTUH)
General, Mixed Products, Approximation	0	0	-10	24	
TOTAL PRODUCT WEIGHT (lb)	0	Total Product Load			0

MISCELLANEOUS LOADS

Quantity	Description	Power	Units	Run Time (hrs)	Load (BTUH)
TOTAL MISCELLANEOUS LOAD					0

SYSTEM DESIGN SUMMARY

Design Load (BTUH)	Safety Factor	Safety Load (BTUH)	Run Time (Hours)	Capacity Required (BTUH)	Refrigerant	Line Frequency (Hz)	Design TD (°F)	Line Loss (°F)
	10%		18		R404A	60	10	0.5

SYSTEM EQUIPMENT SELECTION

Equipment Type	Quantity	Model Number	Description	Voltage	RATING (BTUH)
Condensing Units-Air	1	TEZA025L8-HT3D	EZ-Line Scroll Condensing Units-Air	208-230/3/60	9,373
Evaporator	1	TPLP211LES2DR6	TPLP Low Profile Evaporator	208-230/1/60	11,000

SYSTEM BALANCE

Condenser Ambient (°F)	Suction Temp (°F)	Evaporator TD (°F)	System Capacity (BTUH)
95	-19.2	8.7	9,630



PURCHASER:	SUBMITTED BY:
PROJECT:	DATE: 3/25/2026
ORDER #: -A00	ITEM #: 0
QUOTE #:	ID #:
PURCHASER'S PO#:	TAGGING:

STANDARD FEATURES

- 3/8" Tubing coil construction (reduces refrigerant operating charge)
- Adjustable pressure fan cycling control on 2 fan models only
- Anti-short cycle time delay
- Copper tubing secured with cushion clamps
- Crankcase heater
- Discharge line temperature sensor
- Fan Guard
- Fan motors are inherently protected with internal overloads
- Pre-formed piping
- Receiver with fusible plug and liquid shut off valve
- Suction Service valve
- Adjustable flooded head pressure control (unless otherwise indicated)
- Units are shipped with Helium holding charge
- Weatherproof electrical control box with compressor contactor and fused control circuit
- Welded hermetic Scroll compressor
- Adjustable low pressure control with flex hose / fixed high pressure control
- High efficiency enhanced copper tube and aluminium fin coil design
- Compatible with Low GWP Refrigerants
- Outdoor weatherproof pre-painted steel cabinet

MODEL OPTIONS

OPTION PACKAGES

- Small B (Good@Warm/Moderate)
- Small N (Better@Warm/Moderate)
- Small P (Best@Warm/Moderate)
- Small D (Good@Moderate/Cold)
- Small J (Better@Moderate/Cold)
- Small Q (Best@Moderate/Cold)
- Small K
- Small H
- 115V Control Circuit

ADJUSTABLE PRESSURE CONTROLS

- Johnson Dual with flex hose
- Separate High/Low
- Separate High/Low: MAN Reset on HP

BALL VALVE

- Liquid Line (Shipped Loose)
- Liquid Line (Factory Installed)
- Suction Line (Shipped Loose)
- Suction Line (Factory Installed)

CAPACITY CONTROL - HOT GAS BYPASS

- To Inlet of Evaporator
- To Suction Line
- Compressor Circuit Breaker

CONDENSING UNIT PRISON PACKAGE

- Tamper Proof Screws
- Crankcase Pressure Regulator

CONTACTORS

- 30A Contactor
- 40A Contactor
- 60A Contactor

DEFROST KIT (USE W/KE2 EVAP EFF)

- Up to 30A per Evap
- 35A to 50A per Evap
- Over 50A per Evap
- Discharge Air Hood
- Discharge Line Check Valve
- Discharge Line Temperature Sensor
- Discharge Tee + Ball Valve

DISCONNECT SWITCH

- Fused
- Non-Fused

EC FAN MOTORS + SPEED CONTROLLER

- All Motors Variable Speed - 230V Units
- SmartSpeed

ELECTRONIC CONTROLLER

- KE2 Condensing Unit Control

ELECTRONIC PRESSURE CONTROL

- Low Pressure Control
- High Pressure Control
- Export Crating

COIL COATING

- Heresite Coating
- E-Coat

FIN MATERIAL

- Gold Coat Fins
- Copper Fins
- Hail Guard for Condenser
- Heated and Insulated Receiver

HOUSING MATERIAL

- Stainless Steel
- Insulated Suction Line

LIQUID LINE FILTER + SIGHT GLASS

- Sealed
- Replaceable
- Liquid Line Lock-Out Relay

LIQUID LINE SOLENOID VALVE

- Standard 230V Coil (Shipped Loose)
- Standard 115V Coil (Shipped Loose)

OIL SEPARATOR

- With Oil Filter and Solenoid
- One Time Pump Down
- Oversized Receiver

PHASE / VOLTAGE MONITOR

- 3-Lead
- 6-Lead (MotorSaver455)
- Pump Down Toggle Switch
- Receiver Inlet Ball Valve
- Single Point Electrical
- Sub Cooling Circuit

SUCTION ACCUMULATOR

- With Heat Exchanger
- Without Heat Exchanger

SUCTION FILTER

- Sealed Type
- Replaceable Core

TIME CLOCK

- Paragon 8145 Style (Factory Installed)
- 230V Paragon 8145 Style (Shipped Loose)
- 115V Paragon 8145 Style (Shipped Loose)

Wind Guard

- TQuickVac Valves
- Less Flooding Valve(s)

STOCKING MODEL OPTION PACKAGE F

- Package F

Notes: † MCA.. Minimum Circuit Ampacity, ‡ MOP.. Maximum Overcurrent Protection
 MCA & MOP are for the condensing unit ONLY. Single point connections WILL show different on dataplate.
 AWEF = 3.15 for R404A/R507/407A/R448A/R449A. Non-compliant DOE NRCAN model for all other refrigerants

APPROVALS



APPROVED BY :

DATE :

Approval of this drawing signifies that the equipment is acceptable under the provision of the job specifications. Any change made hereon by any person whomsoever subject to acceptance by NATIONAL REFRIGERATION at its home office.



NATIONAL REFRIGERATION AND
AIR CONDITIONING CANADA CORP.

180 ROY BLVD. PO BOX 2020
BRANTFORD ON
CANADA N3T 5Y6

WHOLESALE DISTRIBUTORS
REFRIGERATION + AIR CONDITIONING
HEATING SUPPLIES & EQUIPMENT

TEZA025L8-11135

EZ-Line Scroll
Condensing Units-Air

PURCHASER:		SUBMITTED BY:	
PROJECT:		DATE: 3/25/2026	
ORDER #: -A00		ITEM #: 0	
QUOTE #:		ID #:	
PURCHASER'S PO#:		TAGGING:	
SELECTED OPTION DESCRIPTIONS			
<u>QuickVac Valves</u>		Brass body valve allowing 3/8" and 1/2" hose connections to the condensing unit for evacuation purposes.	
Approval of this drawing signifies that the equipment is acceptable under the provision of the job specifications. Any change made hereon by any person whomsoever subject to acceptance by NATIONAL REFRIGERATION at its home office.			



NATIONAL REFRIGERATION AND
AIR CONDITIONING CANADA CORP.
159 ROY BLVD. PO BOX 2020
BRANTFORD ON
CANADA N3T 5Y6

WHOLESALE DISTRIBUTORS
REFRIGERATION - AIR CONDITIONING
HEATING SUPPLIES & EQUIPMENT

EZ-Line Scroll
Condensing Units-Air

PURCHASER:	SUBMITTED BY:
PROJECT:	DATE: 3/25/2026
ORDER #: -A00	ITEM #: 0
QUOTE #:	ID #:
PURCHASER'S PO#:	TAGGING:

DIMENSIONS SHOWN ARE FOR STANDARD UNIT LESS OPTIONS.

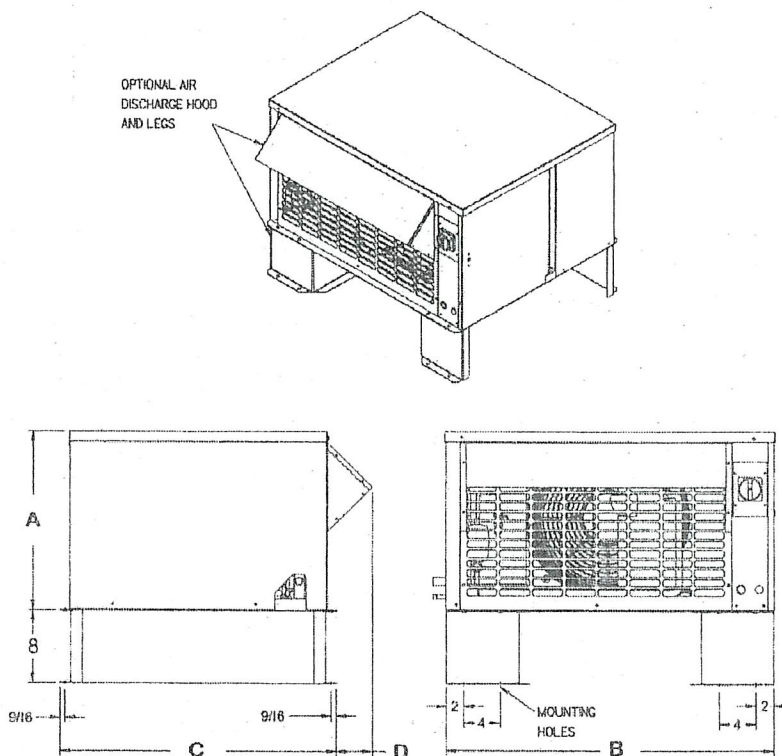

DIMENSIONS				FIELD CONNECTIONS				OTHER			
DIMENSION A	19 7/8 in	DIMENSION E		LIQUID	3/8 in	PAN LOOP		SHIPPING WEIGHT	335 lb		
DIMENSION B	36 3/8 in	DIMENSION F		SUCTION	7/8 in	HOT GAS SIDE PORT		REFRIGERANT CHARGE	6 lb		
DIMENSION C	30 3/8 in	DIMENSION G		DRAIN		HOT GAS INLET		RECEIVER CAPACITY	14 lb		
DIMENSION D	4 in	DIMENSION H		WATER		HOT GAS OUTLET		AWEF COMPLIANT	YES		
				DISCHARGE							
Voltage		SYSTEM REFRIGERANT		RATING		Suction Temp		Ambient Temp		CAPACITY	
208-230/3/60		R404A		2.5Hp		-20.5 °F		95 °F		9,373 BTUH	
Fans			COMPRESSOR				CIRCUIT TOTAL				
QTY	Power	FLA/FAN	Type		QTY	RLA	LRA	AMPS	WATTS	MCA†	MOP‡
1	240	11	ZF08K4E-TF5		1	9.6	63.0	10.7		13.1	20
LIQUID		3/8 in	SOUND		REC CAPACITY			14 lb		APPROVALS:	
SUCTION		7/8 in	WEIGHT		REF CHARGE			6 lb			

Notes: † MCA.. Minimum Circuit Ampacity, ‡ MOP.. Maximum Overcurrent Protection
MCA & MOP are for the condensing unit ONLY. Single point connections WILL show different on dataplate.
AWEF = 3.15 for R404A/R507/407A/R448A/R449A. Non-compliant DOE NRCAN model for all other refrigerants

APPROVED BY:	DATE:
--------------	-------

NATIONAL REFRIGERATION will furnish equipment in accordance with this drawing and specifications, and subject to its published warranty. Approval of this drawing signifies that the equipment is acceptable under the provision of the job specifications. Any change made hereon by any person whomsoever subject to acceptance by NATIONAL REFRIGERATION at its home office



NATIONAL REFRIGERATION AND
AIR CONDITIONING CANADA CORP.
659 ROY BLVD. PO BOX 2020
BRANTFORD ON
CANADA N3T 5Y6

WHOLESALE DISTRIBUTORS
REFRIGERATION - AIR CONDITIONING
HEATING SUPPLIES & EQUIPMENT

UNITED REFRIGERATION INC.
TPLP211LES2DR6

TPLP Low Profile

PURCHASER:		SUBMITTED BY:	
PROJECT:		DATE: 3/25/2026	
ORDER #: -A00		ITEM #: 0	
QUOTE #:		ID #:	
PURCHASER'S PO#:		TAGGING:	

STANDARD FEATURES

- 3/8" Tubing coil construction (reduces refrigerant operating charge)
- Factory installed solenoid valve wire harness
- Heavy gauge textured aluminum cabinet construction resists scratches/corrosion
- Spacious piping end compartment allows for easy assembly
- Hinged drain pan with central universal drain connection (3/4" drain)
- Front access to spacious electrical and header compartments
- Schrader connection on suction header
- Attractive and durable high density polyethylene fan guards
- Ultra efficient Electronically Commutated Motor (ECM)
- ECM with SmartSpeed Technology
- High efficiency enhanced copper tube and aluminium fin coil design
- TPLP evaporator includes TXV, Liquid Line solenoid and Room Thermostat factory installed and wired
- Unit Cooler is DOE/NRCAN compliant with R404A/R507/R448A/R449A/R407A

MODEL OPTIONS

PRE-ASSEMBLED EVAP
 TPLP TXV, LLSV.T-stat (Factory Installed)
 KE2 THERM
 Edge Manager Cell w/BACNet - #21926 (Shipped Loose)

Notes: † MCA.. Minimum Circuit Ampacity, ‡ MOP.. Maximum Overcurrent Protection

APPROVALS	

APPROVED BY: _____ DATE: _____

Approval of this drawing signifies that the equipment is acceptable under the provision of the job specifications. Any change made hereon by any person whomsoever subject to acceptance by NATIONAL REFRIGERATION at its home office.



NATIONAL REFRIGERATION AND
AIR CONDITIONING CANADA CORP.
108 ROY BLVD. PO BOX 2020
BRANTFORD ON
CANADA N3T 5Y6

UNITED REFRIGERATION INC.

WHOLESALE DISTRIBUTORS
REFRIGERATION - AIR CONDITIONING
HEATING SUPPLIES & EQUIPMENT

TPLP Low Profile
Evaporator

PURCHASER:		SUBMITTED BY:	
PROJECT:		DATE: 3/25/2026	
ORDER #: -A00		ITEM #: 0	
QUOTE #:		ID #:	
PURCHASER'S PO#:		TAGGING:	
SELECTED OPTION DESCRIPTIONS			
<p><u>Pre-assembled Evap. TPLP TXV. LLSVT-stat (Factory Installed)</u> thermostat.</p> <p>Option Package consists of factory installed Sporlan balance port TXV, Sporlan liquid line solenoid valve and Johnson Controls A19 Room</p>			
<p>Approval of this drawing signifies that the equipment is acceptable under the provision of the job specifications. Any change made hereon by any person whomsoever subject to acceptance by NATIONAL REFRIGERATION at its home office.</p>			



PURCHASER:	SUBMITTED BY:
PROJECT:	DATE: 3/25/2026
ORDER #: -A00	ITEM #: 0
QUOTE #:	ID #:
PURCHASER'S PO#:	TAGGING:

DIMENSIONS SHOWN ARE FOR STANDARD UNIT LESS OPTIONS.

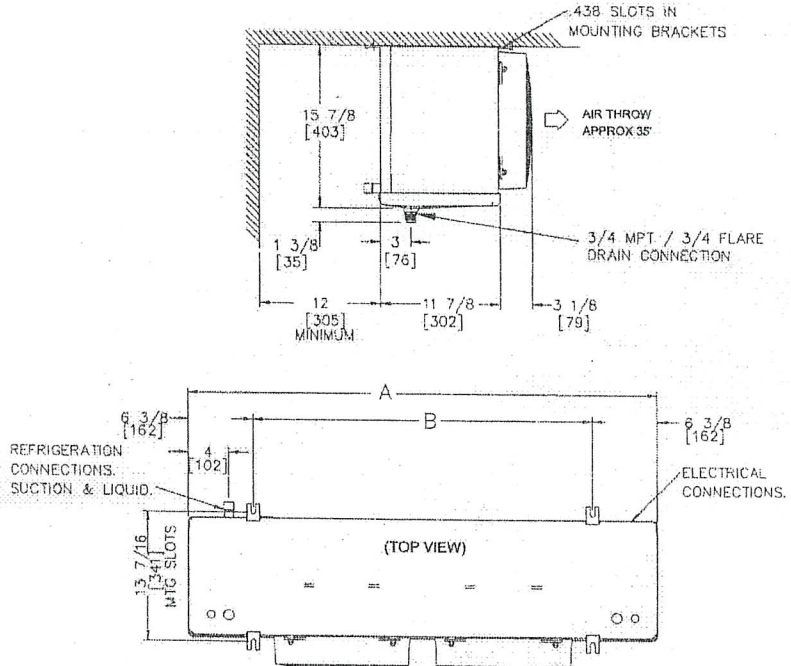

DIMENSIONS				FIELD CONNECTIONS				OTHER			
DIMENSION A	46 1/4 in	DIMENSION E		DISTRIBUTOR	3/8 in	PAN LOOP		SHIPPING WEIGHT	84 lb		
DIMENSION B	33 1/4 in	DIMENSION F		SUCTION	7/8 in	HOT GAS SIDE PORT		REFRIGERANT CHARGE	3 lb		
DIMENSION C		DIMENSION G		DRAIN	3/4 in	HOT GAS INLET		RECEIVER CAPACITY	undefined lb		
DIMENSION D		DIMENSION H		WATER		HOT GAS OUTLET		AWEF COMPLIANT	YES		
				DISCHARGE							
Voltage		SYSTEM REFRIGERANT		AIR FLOW		Evap temperature		Box Temperature		CAPACITY	
208-230/1/60		R404A		1,360 CFM		20 °F		10 °F		11,000 BTUH	
Fans			HEATERS				CIRCUIT TOTAL				
QTY	Power	FLA/FAN	Type		QTY	AMPS	AMPS	WATTS	MCA†	MOP‡	
2	0.07 HP	0.6					1.2	120.0	1.4	15	
DEFROST HEATERS						8.2		1890.0	10.3	15	
DISTRIBUTOR		3/8 in	SOUND	56	REC CAPACITY		undefined lb		APPROVALS:		
SUCTION		7/8 in	WEIGHT	84 lb	REF CHARGE		3 lb				

Notes: † MCA. Minimum Circuit Ampacity, ‡ MOP. Maximum Overcurrent Protection

APPROVED BY:	DATE:
--------------	-------

NATIONAL REFRIGERATION will furnish equipment in accordance with this drawing and specifications, and subject to its published warranty. Approval of this drawing signifies that the equipment is acceptable under the provision of the job specifications. Any change made hereon by any person whomsoever subject to acceptance by NATIONAL REFRIGERATION at its home office.



UR UNITED REFRIGERATION INC. SYSTEMS LOAD SUMMARY

NATIONAL REFRIGERATION AND AIR CONDITIONING CANADA CORP.
 199 ROY BLVD. PO BOX 2020 BRANTFORD ON CANADA N5T 5Y6
WHOLESALE DISTRIBUTORS
REFRIGERATION - AIR CONDITIONING
HEATING SUPPLIES & EQUIPMENT

Prepared By

Prepared For

System: General Walk-in Cooler

Application Title	Location	Interior Temperature	Exterior Temperature	Internal RH	External RH
General Walk-in Cooler	Indoor	35 °F	85 °F	84 %	55 %
Wall Load 0%	Infiltration Load 0%	Product Load 0%	Miscellaneous Load 0%		
Design Load	Safety Load	Run Time	16 Hours	Capacity Required	
SYSTEM BALANCE	SST	24.3 °F	Evaporator TD	10.2 °F	System Capacity
					8,678 BTUH

UNITED REFRIGERATION INC.



NATIONAL REFRIGERATION AND WHOLESALE DISTRIBUTORS GENERAL WALK-IN COOLER
 AIR CONDITIONING CANADA CORP. REFRIGERATION - AIR CONDITIONING
 159 ROY BLVD. PO BOX 202 BRANTFORD ON HEATING SUPPLIES & EQUIPMENT
 CANADA N3T 5V6

Prepared By

Prepared For

COOLING REQUIREMENTS

Application Title	Location	Interior Temperature	External Temperature	Internal RH	External RH
General Walk in Cooler	Indoor	35 °F	85 °F	84%	55%
Wall Load 0%	Infiltration Load 0%	Product Load 0%	Miscellaneous Load 0%		
0 BTUH	0 BTUH	0 BTUH	0 BTUH		

INFILTRATION LOAD : ESTIMATED BY DOORS AND OPENINGS

Quantity	Door or Opening Type	Height (in)	Width (in)	Ext Temp (°F)	External Rh (%)	Open Time (hrs)	Curtains	Load (BTUH)
TOTAL INFILTRATION LOAD ESTIMATED BY DOORS AND OPENINGS								0

PRODUCT LOADS

Type	Weight (lb)	Enter Temp (°F)	Final Temperature (°F)	Pull Down (hrs)	Load (BTUH)
General, Mixed Products, Approximation	0	45	35	24	
TOTAL PRODUCT WEIGHT (lb)	0	Total Product Load		0	

MISCELLANEOUS LOADS

Quantity	Description	Power	Units	Run Time (hrs)	Load (BTUH)
TOTAL MISCELLANEOUS LOAD					0

SYSTEM DESIGN SUMMARY

Design Load (BTUH)	Safety Factor	Safety Load (BTUH)	Run Time (Hours)	Capacity Required (BTUH)	Refrigerant	Line Frequency (Hz)	Design TD (°F)	Line Loss (°F)
	10%		16		R404A	60	10.1	0.5

SYSTEM EQUIPMENT SELECTION

Equipment Type	Quantity	Model Number	Description	Voltage	RATING (BTUH)
Condensing Units-Air	1	TEZA008H8-HT3D	EZ-Line Scroll Condensing Units-Air		8,695
Evaporator	1	TPLP209MASIDR6	TPLP Low Profile Evaporator		8,586

SYSTEM BALANCE

Condenser Ambient (°F)	Suction Temp (°F)	Evaporator TD (°F)	System Capacity (BTUH)
95	24.3	10.2	8,678



NATIONAL REFRIGERATION AND
AIR CONDITIONING CANADA CORP.

89 ROY BLVD. PO BOX 2020
BRANTFORD ON
CANADA N3T 5Y6

WHOLESALE DISTRIBUTORS
REFRIGERATION - AIR CONDITIONING
HEATING SUPPLIES & EQUIPMENT

UNITED REFRIGERATION INC.

TEL: 4008181113 D

EZ-Line Scroll
Condensing Units-Air

PURCHASER:

SUBMITTED BY:

PROJECT:

DATE: 3/25/2026

ORDER #: -A00

ITEM #: 0

QUOTE #:

ID #:

PURCHASER'S PO#:

TAGGING:

STANDARD FEATURES

- 3/8" Tubing coil construction (reduces refrigerant operating charge)
- Adjustable pressure fan cycling control on 2 fan models only
- Anti-short cycle time delay
- Copper tubing secured with cushion clamps
- Crankcase heater
- Discharge line temperature sensor
- Fan Guard
- Fan motors are inherently protected with internal overloads
- Pre-formed piping
- Receiver with fusible plug and liquid shut off valve
- Suction Service valve
- Adjustable flooded head pressure control (unless otherwise indicated)
- Units are shipped with Helium holding charge
- Weatherproof electrical control box with compressor contactor and fused control circuit
- Welded hermetic Scroll compressor
- Adjustable low pressure control with flex hose / fixed high pressure control
- ECM with SmartSpeed Technology
- High efficiency enhanced copper tube and aluminium fin coil design
- Compatible with Low GWP Refrigerants
- Outdoor weatherproof pre-painted steel cabinet

MODEL OPTIONS

OPTION PACKAGES

- Small B (Good@Warm/Moderate)
- Small N (Better@Warm/Moderate)
- Small P (Best@Warm/Moderate)
- Small D (Good@Moderate/Cold)
- Small J (Better@Moderate/Cold)
- Small Q (Best@Moderate/Cold)
- Small K
- Small H
- 115V Control Circuit

ADJUSTABLE PRESSURE CONTROLS

- Johnson Dual with flex hose
- Separate High/Low
- Separate High/Low: MAN Reset on HP

BALL VALVE

- Liquid Line (Shipped Loose)
- Liquid Line (Factory Installed)
- Suction Line (Shipped Loose)
- Suction Line (Factory Installed)

CAPACITY CONTROL - HOT GAS BYPASS

- To Inlet of Evaporator
- To Suction Line

- Compressor Circuit Breaker

CONDENSING UNIT PRISON PACKAGE

- Tamper Proof Screws
- Crankcase Pressure Regulator

CONTACTORS

- 30A Contactor
- 40A Contactor
- 60A Contactor

DEFROST KIT (USE W/KE2 EVAP EFF)

- Up to 30A per Evap
- 35A to 50A per Evap
- Over 50A per Evap
- Discharge Air Hood
- Discharge Line Check Valve
- Discharge Tee + Ball Valve

DISCONNECT SWITCH

- Fused
- Non-Fused

EC FAN MOTORS + SPEED CONTROLLER

- All Motors Variable Speed - 230V Units

ELECTRONIC CONTROLLER

- KE2 Condensing Unit Control

ELECTRONIC PRESSURE CONTROL

- Low Pressure Control
- High Pressure Control

- Export Crating

- Extended Leg Kit

COIL COATING

- Heresite Coating
- E-Coat

FIN MATERIAL

- Gold Coat Fins
- Copper Fins
- Hail Guard for Condenser
- Heated and Insulated Receiver

HOUSING MATERIAL

- Stainless Steel
- Insulated Suction Line

LIQUID LINE FILTER + SIGHT GLASS

- Sealed
- Replaceable
- Liquid Line Lock-Out Relay
- LIQUID LINE SOLENOID VALVE**
- Standard 230V Coil (Shipped Loose)
- Standard 115V Coil (Shipped Loose)

OIL SEPARATOR

- With Oil Filter and Solenoid
- One Time Pump Down
- Oversized Receiver

PHASE / VOLTAGE MONITOR

- 3-Lead
- 6-Lead (MotorSaver455)
- Pump Down Toggle Switch
- Receiver Inlet Ball Valve
- Single Point Electrical

SUCTION ACCUMULATOR

- With Heat Exchanger
- Without Heat Exchanger

SUCTION FILTER

- Sealed Type
- Replaceable Core

TIME CLOCK

- Paragon 8145 Style (Factory Installed)
- 230V Paragon 8145 Style (Shipped Loose)
- 115V Paragon 8145 Style (Shipped Loose)
- Wind Guard

- TQuickVac Valves
- Less Flooding Valve(s)

STOCKING MODEL OPTION PACKAGE F

- Package F

Notes: † MCA.. Minimum Circuit Ampacity, ‡ MOP.. Maximum Overcurrent Protection
MCA & MOP are for the condensing unit ONLY. Single point connections WILL show different on dataplate.
AWEF = 7.6 for R404A/R507/R407A/R448A/R449A. Non-compliant DOE NRCAN model for all other refrigerants

APPROVALS



APPROVED BY:

DATE:

Approval of this drawing signifies that the equipment is acceptable under the provision of the job specifications. Any change made hereon by any person whomsoever subject to acceptance by NATIONAL REFRIGERATION at its home office.



NATIONAL REFRIGERATION AND
AIR CONDITIONING CANADA CORP.
159 ROY BLVD. PO BOX 2020
BRANTFORD ON
CANADA N3T 5V6

**WHOLESALE DISTRIBUTORS
REFRIGERATION - AIR CONDITIONING
HEATING SUPPLIES & EQUIPMENT**

TEZA00818-113D

EZ-Line Scroll
Condensing Units-Air

PURCHASER:	SUBMITTED BY:
PROJECT:	DATE: 3/25/2026
ORDER #: -A00	ITEM #: 0
QUOTE #:	ID #:
PURCHASER'S PO#:	TAGGING:
SELECTED OPTION DESCRIPTIONS	
<u>QuickVac Valves</u>	Brass body valve allowing 3/8" and 1/2" hose connections to the condensing unit for evacuation purposes.
Approval of this drawing signifies that the equipment is acceptable under the provision of the job specifications. Any change made hereon by any person whomsoever subject to acceptance by NATIONAL REFRIGERATION at its home office.	



NATIONAL REFRIGERATION AND AIR CONDITIONING CANADA CORP. **UR UNITED REFRIGERATION INC.**

159 ROY BLVD. PO BOX 2020
BRANTFORD ON
CANADA N3T 5V6

**WHOLESALE DISTRIBUTORS
REFRIGERATION - AIR CONDITIONING
HEATING SUPPLIES & EQUIPMENT**

EZ-Line Scroll
Condensing Units-Air

PURCHASER:

SUBMITTED BY:

PROJECT:

DATE: 3/25/2026

ORDER #: -A00

ITEM #: 0

QUOTE #:

ID #:

PURCHASER'S PO#:

TAGGING:

DIMENSIONS SHOWN ARE FOR STANDARD UNIT LESS OPTIONS.

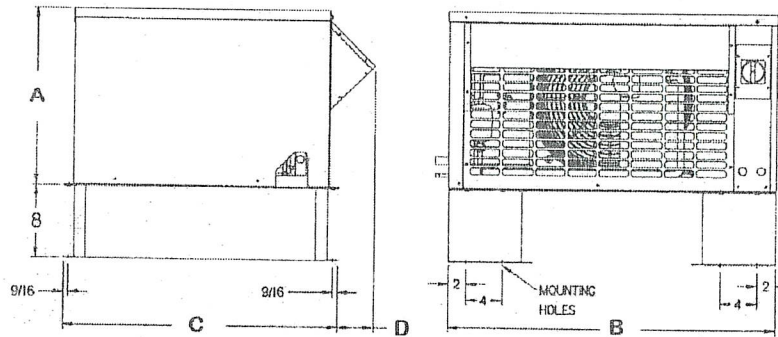
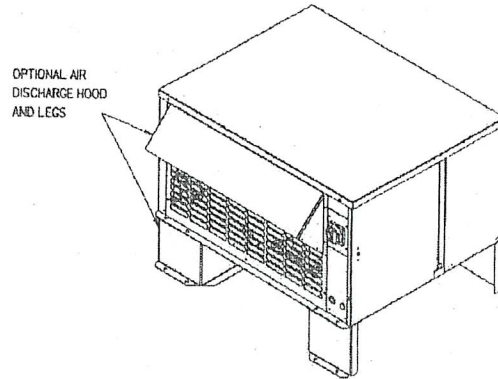

DIMENSIONS				FIELD CONNECTIONS				OTHER			
DIMENSION A	19 3/8 in	DIMENSION E		LIQUID	3/8 in	PAN LOOP		SHIPPING WEIGHT	188 lb		
DIMENSION B	24 7/8 in	DIMENSION F		SUCTION	5/8 in	HOT GAS SIDE PORT		REFRIGERANT CHARGE	3 lb		
DIMENSION C	30 3/8 in	DIMENSION G		DRAIN		HOT GAS INLET		RECEIVER CAPACITY	5 lb		
DIMENSION D	4 in	DIMENSION H		WATER		HOT GAS OUTLET		AWEF COMPLIANT	YES		
				DISCHARGE							
Voltage		SYSTEM REFRIGERANT		RATING		Suction Temp		Ambient Temp		CAPACITY	
		R404A		0.8Hp		24.4 °F		95 °F		8,695 BTUH	
Fans			COMPRESSOR				CIRCUIT TOTAL				
QTY	Power	FLA/FAN	Type		QTY	RLA	LRA	AMPS	WATTS	MCA†	MOP‡
1	100	1.0	ZB07KAE-TF5		1	5.2	37.8	6.2		7.5	15
LIQUID		3/8 in	SOUND		REC CAPACITY				5 lb	APPROVALS:	
SUCTION		5/8 in	WEIGHT		REF CHARGE				3 lb		

Notes: † MCA. Minimum Circuit Ampacity, ‡ MOP. Maximum Overcurrent Protection
MCA & MOP are for the condensing unit ONLY. Single point connections WILL show different on dataplate.
AWEF = 7.6 for R404A/R507/R407A/R448A/R449A. Non-compliant DOE NRCAN model for all other refrigerants

APPROVED BY :

DATE :

NATIONAL REFRIGERATION will furnish equipment in accordance with this drawing and specifications, and subject to its published warranty. Approval of this drawing signifies that the equipment is acceptable under the provision of the job specifications. Any change made hereon by any person whomsoever subject to acceptance by NATIONAL REFRIGERATION at its home office.



NATIONAL REFRIGERATION AND
AIR CONDITIONING CANADA CORP.
189 ROY BLVD. PO BOX 2020
BRANTFORD ON
CANADA N3T 5V6

UNITED REFRIGERATION INC

WHOLESALE DISTRIBUTORS
REFRIGERATION - AIR CONDITIONING
HEATING SUPPLIES & EQUIPMENT

TPLP209MASTER6
TPLP Low Profile

PURCHASER:	SUBMITTED BY:
PROJECT:	DATE: 3/25/2026
ORDER #: -A00	ITEM #: 0
QUOTE #:	ID #:
PURCHASER'S PO#:	TAGGING:

STANDARD FEATURES

- 3/8" Tubing coil construction (reduces refrigerant operating charge)
- Factory installed solenoid valve wire harness
- Heavy gauge textured aluminum cabinet construction resists scratches/corrosion
- Spacious piping end compartment allows for easy assembly
- Hinged drain pan with central universal drain connection (3/4" drain)
- Front access to spacious electrical and header compartments
- Schrader connection on suction header
- Attractive and durable high density polyethylene fan guards
- Ultra efficient Electronically Commutated Motor (ECM)
- ECM with SmartSpeed Technology
- High efficiency enhanced copper tube and aluminium fin coil design
- TPLP evaporator includes TXV, Liquid Line solenoid and Room Thermostat factory installed and wired
- AWEF = 9.0
- Unit Cooler is DOE/NRCAN compliant with R404A/R507/R448A/R449A/R407A/R407C

MODEL OPTIONS

- PRE-ASSEMBLED EVAP TPLP TXV, LLSV.T-stat (Factory Installed)
- KE2 THERM Edge Manager Cell w/BACNet - #21926 (Shipped Loose)

Notes: † MCA.. Minimum Circuit Ampacity, ‡ MOP.. Maximum Overcurrent Protection

APPROVALS

APPROVED BY :	DATE :
---------------	--------

Approval of this drawing signifies that the equipment is acceptable under the provision of the job specifications. Any change made hereon by any person whomsoever subject to acceptance by NATIONAL REFRIGERATION at its home office.



NATIONAL REFRIGERATION AND AIR CONDITIONING CANADA CORP. **UNIVERSITY UNITED REFRIGERATION INC.**

150 ROY BLVD. PO BOX 2020
BRANTFORD ON
CANADA N3T 5Y6

**WHOLESALE DISTRIBUTORS
REFRIGERATION - AIR CONDITIONING
HEATING SUPPLIES & EQUIPMENT**

TPLP 209MAST DRG

TPLP Low Profile
Evaporator

PURCHASER:		SUBMITTED BY:	
PROJECT:		DATE: 3/25/2026	
ORDER #: -A00		ITEM #: 0	
QUOTE #:		ID #:	
PURCHASER'S PO#:		TAGGING:	
SELECTED OPTION DESCRIPTIONS			
<u>Pre-assembled Evap. TPLP TXV, LLSV, T-stat (Factory Installed)</u> thermostat.			
Option Package consists of factory installed Sporlan balance port TXV, Sporlan liquid line solenoid valve and Johnson Controls A19 Room			
Approval of this drawing signifies that the equipment is acceptable under the provision of the job specifications. Any change made hereon by any person whomsoever subject to acceptance by NATIONAL REFRIGERATION at its home office.			



NATIONAL REFRIGERATION AND
AIR CONDITIONING CANADA CORP.

659 ROY BLVD. PO BOX 2020
BRANTFORD ON
CANADA N5T 5V5

WHOLESALE DISTRIBUTORS
REFRIGERATION - AIR CONDITIONING
HEATING SUPPLIES & EQUIPMENT

TPLP209MASTER6

TPLP Low Profile

PURCHASER:

SUBMITTED BY:

PROJECT:

DATE: 3/25/2026

ORDER #: -A00

ITEM #: 0

QUOTE #:

ID #:

PURCHASER'S PO#:

TAGGING:

DIMENSIONS SHOWN ARE FOR STANDARD UNIT LESS OPTIONS.

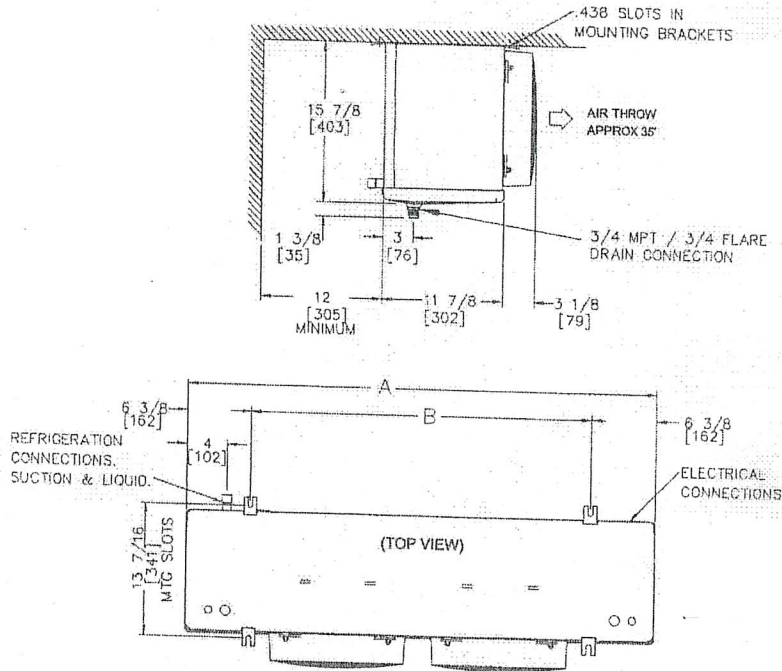

DIMENSIONS			FIELD CONNECTIONS				OTHER	
DIMENSION A	46 1/4 in	DIMENSION E	DISTRIBUTOR	3/8 in	PAN LOOP	SHIPPING WEIGHT	70 lb	
DIMENSION B	33 1/4 in	DIMENSION F	SUCTION	7/8 in	HOT GAS SIDE PORT	REFRIGERANT CHARGE	1 lb	
DIMENSION C		DIMENSION G	DRAIN	3/4 in	HOT GAS INLET	RECEIVER CAPACITY	undefined lb	
DIMENSION D		DIMENSION H	WATER		HOT GAS OUTLET	AWEF COMPLIANT	YES	
			DISCHARGE					
Voltage	SYSTEM REFRIGERANT		AIR FLOW	Evap temperature		Box Temperature	CAPACITY	
	R404A		1,500 CFM	24.9 °F		35 °F	8,586 BTUH	
Fans			HEATERS			CIRCUIT TOTAL		
QTY	Power	FLA/FAN	Type	QTY	AMPS	AMPS	WATTS	
2	0.07 HP	1.0				2.0	120.0	
DISTRIBUTOR		3/8 in	SOUND	56	REC CAPACITY	undefined lb		
SUCTION		7/8 in	WEIGHT	70 lb	REF CHARGE	1 lb		
APPROVALS:								

Notes: † MCA.. Minimum Circuit Ampacity, ‡ MOP.. Maximum Overcurrent Protection

APPROVED BY:

DATE:

NATIONAL REFRIGERATION will furnish equipment in accordance with this drawing and specifications, and subject to its published warranty. Approval of this drawing signifies that the equipment is acceptable under the provision of the job specifications. Any change made hereon by any person whomsoever subject to acceptance by NATIONAL REFRIGERATION at its home office.

Garmon Mechanical Service Inc.

Job References

Company Name: Carolina Pizza Huts

Contact Name & Title: Will – General manager

Direct Phone Number: 704-425-8067

Company Name: Atrium Health - Stanly

Contact Name & Title: Danny Dennis – Director of Facilities

Direct Phone Number: 980-521-8058

Company Name: Trinity Place Assisted Living

Contact Name & Title: Adam Stirewalt – Facility Manager

Direct Phone Number: 704-244-6103

License Number
2967

North Carolina State
Board of
Refrigeration Contractors

Expiration Date
December 31, 2026

This is to Certify that:

Robert L Garmon, Jr.

Garmon Mechanical Service, Inc.
P O Box 1136
Albemarle, NC 28002

*Is duly registered, licensed and entitled to engage in the business
of Refrigeration Contracting in the State of North Carolina.*

**Commercial Refrigeration Contractor
Transport Refrigeration Contractor
Industrial Refrigeration Contractor**

*This authority is granted in accordance with the provisions of
Chapter 87, Article 5 of the General Statutes of North Carolina.*

Witness our hands and seal of the Board, Raleigh, N.C.

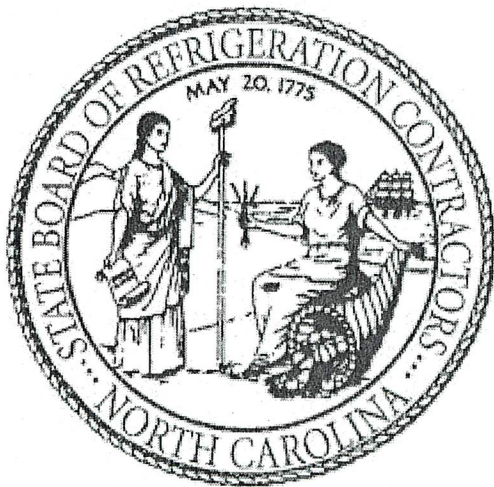

Paul Cook

Chairman
H. O. Hill

Secretary
Ronan Reed

Treasurer



CERTIFICATE OF LIABILITY INSURANCE

DATE (MM/DD/YYYY)
03/23/2026

THIS CERTIFICATE IS ISSUED AS A MATTER OF INFORMATION ONLY AND CONFERS NO RIGHTS UPON THE CERTIFICATE HOLDER. THIS CERTIFICATE DOES NOT AFFIRMATIVELY OR NEGATIVELY AMEND, EXTEND OR ALTER THE COVERAGE AFFORDED BY THE POLICIES BELOW. THIS CERTIFICATE OF INSURANCE DOES NOT CONSTITUTE A CONTRACT BETWEEN THE ISSUING INSURER(S), AUTHORIZED REPRESENTATIVE OR PRODUCER, AND THE CERTIFICATE HOLDER.

IMPORTANT: If the certificate holder is an ADDITIONAL INSURED, the policy(ies) must have ADDITIONAL INSURED provisions or be endorsed. If SUBROGATION IS WAIVED, subject to the terms and conditions of the policy, certain policies may require an endorsement. A statement on this certificate does not confer rights to the certificate holder in lieu of such endorsement(s).

PRODUCER Childress Insurance Partners 146 E Main St Albemarle NC 28001		CONTACT NAME: Pamela Morton PHONE (A/C, No, Ext): 704-557-2438 E-MAIL ADDRESS: pmorton@legacyinspartners.com FAX (A/C, No):	
INSURED Garmon Mechanical Service Inc Po Box 1136 Albemarle NC 28002		INSURER(S) AFFORDING COVERAGE INSURER A: Penn National Mutual NAIC # 14990 INSURER B: Business First NAIC # 11697 INSURER C: INSURER D: INSURER E: INSURER F:	

COVERAGES **CERTIFICATE NUMBER:** **REVISION NUMBER:**

THIS IS TO CERTIFY THAT THE POLICIES OF INSURANCE LISTED BELOW HAVE BEEN ISSUED TO THE INSURED NAMED ABOVE FOR THE POLICY PERIOD INDICATED. NOTWITHSTANDING ANY REQUIREMENT, TERM OR CONDITION OF ANY CONTRACT OR OTHER DOCUMENT WITH RESPECT TO WHICH THIS CERTIFICATE MAY BE ISSUED OR MAY PERTAIN, THE INSURANCE AFFORDED BY THE POLICIES DESCRIBED HEREIN IS SUBJECT TO ALL THE TERMS, EXCLUSIONS AND CONDITIONS OF SUCH POLICIES. LIMITS SHOWN MAY HAVE BEEN REDUCED BY PAID CLAIMS.

INSR LTR	TYPE OF INSURANCE	ADDL INSD	SUBR WVD	POLICY NUMBER	POLICY EFF (MM/DD/YYYY)	POLICY EXP (MM/DD/YYYY)	LIMITS
A	<input checked="" type="checkbox"/> COMMERCIAL GENERAL LIABILITY <input type="checkbox"/> CLAIMS-MADE <input checked="" type="checkbox"/> OCCUR GEN'L AGGREGATE LIMIT APPLIES PER: <input type="checkbox"/> POLICY <input checked="" type="checkbox"/> PRO-JECT <input type="checkbox"/> LOC OTHER:	Y		CL92031632	7/29/2025	7/29/2026	EACH OCCURRENCE \$ 1,000,000 DAMAGE TO RENTED PREMISES (Ea occurrence) \$ 500,000 MED EXP (Any one person) \$ 10,000 PERSONAL & ADV INJURY \$ 1,000,000 GENERAL AGGREGATE \$ 2,000,000 PRODUCTS - COMP/OP AGG \$ 2,000,000
A	AUTOMOBILE LIABILITY <input checked="" type="checkbox"/> ANY AUTO <input type="checkbox"/> OWNED AUTOS ONLY <input type="checkbox"/> SCHEDULED AUTOS <input checked="" type="checkbox"/> HIRED AUTOS ONLY <input checked="" type="checkbox"/> NON-OWNED AUTOS ONLY			AU92031632	7/29/2025	7/29/2026	COMBINED SINGLE LIMIT (Ea accident) \$ 1000000 BODILY INJURY (Per person) \$ BODILY INJURY (Per accident) \$ PROPERTY DAMAGE (Per accident) \$
A	<input checked="" type="checkbox"/> UMBRELLA LIAB <input checked="" type="checkbox"/> OCCUR <input type="checkbox"/> EXCESS LIAB <input type="checkbox"/> CLAIMS-MADE DED <input checked="" type="checkbox"/> RETENTION \$ 10,000			UL92031632	7/29/2025	7/29/2026	EACH OCCURRENCE \$ 4,000,000 AGGREGATE \$ 4,000,000
B	WORKERS COMPENSATION AND EMPLOYERS' LIABILITY ANY PROPRIETOR/PARTNER/EXECUTIVE OFFICER/MEMBER EXCLUDED? (Mandatory in NH) If yes, describe under DESCRIPTION OF OPERATIONS below	Y/N I	N/A	0521-23645	10/1/2025	10/1/2026	<input checked="" type="checkbox"/> PER STATUTE <input type="checkbox"/> OTH-ER E.L. EACH ACCIDENT \$ 1,000,000 E.L. DISEASE - EA EMPLOYEE \$ 1,000,000 E.L. DISEASE - POLICY LIMIT \$ 1,000,000

DESCRIPTION OF OPERATIONS / LOCATIONS / VEHICLES (ACORD 101, Additional Remarks Schedule, may be attached if more space is required)

Union County, It's Officers, Agents and employees ar Additional Insured with respects to general liability

CERTIFICATE HOLDER Union County Union County Risk Manager 500 N Main St., Ste 130 Monroe NC 28112	CANCELLATION SHOULD ANY OF THE ABOVE DESCRIBED POLICIES BE CANCELLED BEFORE THE EXPIRATION DATE THEREOF, NOTICE WILL BE DELIVERED IN ACCORDANCE WITH THE POLICY PROVISIONS. AUTHORIZED REPRESENTATIVE <i>Pamela T. Morton</i>
--	---



Re-Bid Opening Tabulation
Union County, North Carolina
IFB 2026-051 Detention Center Freezer and Cooler Replacement
Procurement Conference Room, 610 Patton Ave, Monroe, NC
March 25, 2026 2:00 PM

Bids Opened and Recorded by Juan Rodriguez-Cruz 3/25/2026

Company Name	NC Class 1 Commercial Refrigeration License.	NC Electrical License	Non-Collusion Affidavit Received? (Yes/No)	Signed Bid Form	Addenda Acknowledgement	Bid Total
MC Moore Construction	L. 04743	10661	X	X	X	\$162,568.00
Garmon Mechanical Services	2967/11602	31209	X	X	X	\$159,392.10
Eastern Refrigeration	Yes	No	No	No	No	\$287,888.34

To: Corey Brooks, Director Procurement and Contract Management

From: James Mangum Jr "Buck", Facilities Project Manager

CC: Christopher Boyd, Director of Facilities and Fleet Management
Linda Whitaker, Assistant Director of Design and Construction

Date: March 30, 2026

Re: Recommendation to Award
Rebid of IFB 2026-051 Detention Center Walk-in Freezer and Cooler Replacement

On March 25, 2026, at 2:00 PM bids were received for the Rebid for IFB 2026-051 Detention Center Walk-in Freezer and Cooler Replacement. Three (3) bids were received from a licensed general contractor and read out loud publicly.

Of the Three (3) received, Garmon Mechanical Services was the apparent low bid for a total bid of \$159,392.10. Upon review of Garmon Mechanical Service, Inc. bid submittal and required supporting documents appear to be complete and responsive. Therefore, based upon this information, I make the recommendation to award this contract to Garmon Mechanical Services, Inc in the amount of \$159,392.10. The supporting Certified Bid Tabulation is attached as well as the bid form and the supporting documentation.

James Mangum

James Mangum
Facilities Project Manager
03/30/2026

1. AGREEMENT. This agreement (“Agreement”) is entered into on _____, by and between UNION COUNTY, a political subdivision of the State of North Carolina (“Union”), and Garmon Mechanical Service Inc (“Contractor”), whose business address is 502 Old Charlotte Road Albemarle, NC 28001.

2. INDEPENDENT CONTRACTOR. Contractor shall be an independent contractor in all its activities pursuant to this Agreement. Neither Contractor nor any of its employees are to be considered Union's employee or agent for any purpose including, but not limited to, the accrual of any employee benefits. Contractor is not authorized to represent Union or otherwise bind Union in any dealings between Contractor and third parties. Any employees furnished by Contractor under this Agreement shall be deemed to be Contractor's employees exclusively.

3. SCOPE OF THE WORK. Contractor shall furnish all labor, equipment, tools, materials, supplies, transportation, tests and supervision required to complete in a workmanlike manner the work described in the IFB 2026-051 Detention Center Walk-In Freezer and Cooler Replacement, which is attached hereto and incorporated herein by reference (“Work”). Union is not financially committed by this agreement to purchase any minimum amount of services.

4. PERIOD OF PERFORMANCE. This Agreement shall commence as of the date first written above and shall continue until the earlier of the completion and acceptance of the Work. Contractor shall promptly commence Work and shall achieve completion of the Work within One Hundred -Twenty (120) days from Contractor’s receipt of notice to proceed from Union.

5. PAYMENT FOR WORK. Union shall pay Contractor, Base Bid \$151,802.00 with a 5% Owners Contingency of \$7590.10. Total Bid Base Bid + Contingency = \$159,392.10 for Work, as set forth in the Contractor’s bid, which is attached hereto and incorporated herein by reference. Payment for work satisfactorily completed shall be made within thirty (30) days of receipt of invoice by Union’s finance office. Contractor shall submit documentation supporting its entitlement to payment as required by Union, and Union shall have no obligation to pay Contractor unless and until Union has received such documentation. All payments shall be conditioned upon appropriation by the Union County Board of Commissioners of sufficient funds for each request for services.

6. LICENSING REQUIREMENTS. Contractor represents and warrants that it is and shall remain properly licensed at all times in the performance of Work.

7. PERMITS AND LICENSES. Unless otherwise agreed in writing in advance by Union, Contractor shall obtain and pay for all licenses and permits that are required for it to perform Work.

8. COMPLIANCE WITH LAWS/COMPLIANCE WITH RULES AND POLICIES OF UNION. In performing the services pursuant to this Agreement, Contractor shall comply

with all laws, rules, regulations, ordinances, codes, standards, and orders of any and all governmental bodies, agencies, authorities, and courts having jurisdiction. Contractor also shall comply with all rules and policies of Union.

9. INSURANCE. Contractor shall comply with the insurance requirements set forth in Exhibit A, attached and incorporated herein by reference.

No workers' compensation insurance shall be obtained by Union concerning Contractor or the employees of Contractor. Contractor shall comply with the workers' compensation law concerning Contractor and the employees of Contractor.

10. TAXES. Contractor shall be responsible for paying all taxes, fees, assessments and premiums of any kind payable on its employees and operations. Contractor shall substantiate, on demand by Union, that all taxes and other charges are being properly paid.

Pursuant to N.C.G.S. § 105-164.14, Union is eligible for sales and use tax refunds on all materials which become a permanent part of the construction. Contractor agrees to provide Union such documentation as may be necessary to meet the requirements of the North Carolina Department of Revenue regarding requests for refund of sales and use taxes. Such requirements include those described in the North Carolina Department of Revenue Sales and Use Tax Technical Bulletins § 18-2(F), outlined below:

To substantiate a refund claim for sales or use taxes paid on purchases of building materials, supplies, fixtures, and equipment by a contractor, Union must secure from a contractor certified statements setting forth the specific required information. A "certified statement" is a statement signed by a contractor's Union, a corporate officer of a contractor, or an employee of a contractor who is authorized to provide information set forth in the statement. The certified statement must include all of the following information:

- a. The date the property was purchased;
- b. The type of property purchased;
- c. The cost of property purchased and the amount of sales and use taxed paid thereon;
- d. The vendor from whom the property was purchased;
- e. The project for which the property was purchased;
- f. If the property was purchased in the State of North Carolina, the county to which it was delivered, or, if the property was not purchased in the State of North Carolina, the county in which the property was used; and
- g. The invoice number of the purchase.

In the event Contractor makes several purchases from the same vendor, such certified statement must indicate the invoice numbers, the inclusive dates of the invoices, the total amount of the invoices, and the State and local sales and use taxes paid thereon. Such statement must also include the cost of any tangible personal property withdrawn from

Contractor's warehouse stock and the amount of State and local sales or use tax paid thereon by Contractor. Any local sales or use taxes included in Contractor's statements must be shown separately from the State sales or use taxes. Contractor's statements must not contain sales or use taxes paid on purchases of tangible personal property purchased by Contractor for use in performing the Contract which does not annex to, affix to or in some manner become a part of the building or structure that is owned or leased by a governmental agency and is being erected, altered or repaired for use by a governmental entity as defined by N.C.G.S. § 105-164.14(c). Examples of property on which sales or use tax has been paid by Contractor and which shall not be included in Contractor's certified statement are scaffolding, forms for concrete, fuel for the operation of machinery and equipment, tools, equipment, equipment repair parts and equipment rentals. Similar certified statements by Subcontractors must be obtained by Contractor and furnished to Union.

Contractor shall submit notarized sales tax certificates which meet the requirements detailed above with each Application for Payment. Payment will not be made until the sales tax certificate(s) have been submitted to Union. Union is the recipient of sales tax refunds and no such funds shall be provided to Contractor, or claim made by Contractor therefor.

11. **WARRANTY OF WORK.** Contractor warrants that all Work shall be new, unless otherwise agreed in this Agreement, and of good quality and performed in a good and workmanlike manner. Contractor shall, at its own expense, at the request of Union, promptly replace or repair any defective or deficient Work for a period of one year after completion of Work. The express warranty contained in this section shall not diminish any of Union's rights against Contractor with respect to the time within which proceedings may be commenced to establish Contractor's liability with respect to Contractor's obligations other than specifically to correct Work.

12. **SAFETY.** Contractor shall establish and enforce safe working procedures at all times during its performance of Work in accordance with all federal, state and local laws, ordinances, rules and regulations pertaining to safety.

13. **AGE LIMITS.** No employee of Contractor under the age of 18 shall be permitted on property owned or leased by Union.

14. **CLEANUP.** Contractor shall keep its work areas clean of debris and excess materials, and at the end of each day will leave its work areas in broom-clean condition. If Contractor fails to clean up as required herein, Union may clean up and deduct the cost from Contractor's payment.

15. **LIABILITY.** Contractor agrees to protect, defend, indemnify and hold Union County, its officers, employees and agents free and harmless from and against any and all losses, penalties, damages, settlements, costs, charges, professional fees or other expenses or liabilities of every kind and character arising out of or relating to any and all claims, liens, demands, obligations, actions, proceedings, or causes of action of every kind in connection with or arising out of this agreement and/or the performance hereof that are due, in whole or in part, to the

negligence of the Contractor, its officers, employees, subcontractors or agents. Contractor further agrees to investigate, handle, respond to, provide defense for, and defend the same at its sole expense and agrees to bear all other costs and expenses related thereto.

16. “RESERVED”

17. LIQUIDATED DAMAGES. Contractor and Union recognize that time is of the essence and that Union will suffer financial loss if the Work is not completed within the times specified in Section 4 herein. The parties also recognize the delays, expense, and difficulties involved in proving in a legal proceeding the actual loss suffered by Union if the Work is not completed on time. Accordingly, instead of requiring any such proof, Union and Contractor agree that as liquidated damages for delay (but not as a penalty), Contractor shall pay Union Two Hundred-Fifty Dollars (\$250.00) for each day that expires after the time specified in Section 4 herein for substantial completion until the Work is substantially complete.

18. DEFAULT/TERMINATION. If Contractor fails or refuses to supply sufficient and properly skilled labor, equipment or materials, or fails in any respect to diligently prosecute Work, or otherwise is in default or breach of any term of this Agreement, Union may terminate this Agreement upon 24 hours' written notice. In the event of such termination, Contractor immediately will stop work and remove its employees from Union's property. Union may complete the Work in whatever way it determines best, and at completion of the Work shall pay Contractor for the value of the Work performed by Contractor (excluding profit) but unpaid prior to the termination, less any costs incurred by Union to correct any deficiencies or defects attributable to Contractor's work.

19. TERMINATION FOR CONVENIENCE. Union may terminate this Agreement at any time upon three (3) days' written notice to Contractor. Such termination shall be effective in the manner specified in such written notice. Upon a termination for convenience, Union shall pay Contractor for Work performed to the date of termination. Contractor shall accept such payment in full and final payment and shall make no claim of any kind against Union, including but not limited to any claim for any additional payment.

20. ASSIGNMENT. Neither this Agreement, nor any payments to be earned pursuant to this Agreement, may be assigned by Contractor without the prior written consent of Union.

21. NO WAIVER. Union's not insisting upon strict compliance with any of the provisions of this Agreement, or not exercising any of its options provided herein, shall not be construed as a waiver of its right thereafter to require such compliance or to exercise any such options.

22. E-VERIFY. E-Verify is the federal program operated by the United States Department of Homeland Security and other federal agencies, or any successor or equivalent program, used to verify the work authorization of newly hired employees pursuant to federal law. Contractor shall ensure that Contractor and any subcontractor performing work under this Agreement: (i) uses E-Verify if required to do so by North Carolina law; and (ii) otherwise complies with the requirements of Article 2 of Chapter 64 of the North Carolina General

Statutes. A breach of this provision by Contractor will be considered a breach of this Agreement, which entitles Union to terminate this Agreement, without penalty, upon notice to Contractor.

23. ENTIRE AGREEMENT. This Agreement represents the entire agreement of the parties, and may not be modified except in writing signed by both parties.

24. GOVERNING LAW. This Agreement shall be construed and enforced in accordance with the laws of the State of North Carolina. The parties to this agreement confer exclusive jurisdiction of all disputes arising hereunder upon the General Courts of Justice of Union County, North Carolina.

25. AUTHORITY. Each signatory below warrants that it has the corporate or other organizational power and authority to execute, deliver and perform this Agreement. Each signatory further warrants that the execution, delivery and performance by it of the Agreement has been duly authorized and approved by all requisite action of the party's management and appropriate governing body.

IN WITNESS WHEREOF, the parties hereto, acting under authority of their respective governing bodies, have hereunto set their hands and seals and caused this Agreement to be duly executed, this the day and year first above written.

UNION COUNTY

[Garmon Mechanical Service Inc]

By: _____ (SEAL)
Brian W. Matthews, County Manager

By: _____ (SEAL)

This instrument has been preaudited in the manner required by The Local Government Budget and Fiscal Control Act.

Approved as to Legal Form _____

Deputy Finance Officer

**RESOLUTION OF THE UNION COUNTY BOARD OF COMMISSIONERS
PROVIDING NOTICE OF THE DETENTION CENTER WALK-IN
FREEZER AND COOLER REPLACEMENT PROJECT**

WHEREAS, pursuant to G.S § 153A-457, a county shall notify property owners and adjacent property owners prior to commencement of any construction project by the county; and

WHEREAS, G.S. § 153A-457 provides that notice of a county construction project is deemed sufficient if notice of the construction project is given in any open meeting of the county prior to the commencement of the construction project; and

WHEREAS, the Union County Board of Commissioners desires to give notice of construction of the **DETENTION CENTER WALK-IN FREEZER AND COOLER REPLACEMENT PROJECT** prior to commencement of project construction as required by G.S. § 153A-457.

NOW, THEREFORE, BE IT RESOLVED BY THE Union County Board of Commissioners that:

1. Union County may commence construction of the **DETENTION CENTER WALK-IN FREEZER AND COOLER REPLACEMENT PROJECT** on property located at 3344 Presson Road, Monroe, NC after the award of the construction contract for the project.
2. This resolution and notice is adopted in accordance with the construction notice requirements of G.S. § 153A-457.

Adopted this the 4th day of May, 2026.

Attest:

Lynn West, Clerk to the Board

Brian Helms, Chairman
Union County Board of Commissioners



Union County, NC

Staff Report

Union County Government
Center
500 North Main Street
Monroe, North Carolina
www.unioncountync.gov

File #: 26-195

Agenda Date: 5/4/2026

TITLE:

Capital Project Ordinance Amendments to Reduce Arbitrage Rebates

INFORMATION CONTACT:

Beverly Liles, Finance, Director, 704-283-3675

ACTION REQUESTED:

1) Adopt Capital Project Ordinance Amendments 211A, 239B, 254A, 273B, 277B, 283C, 284D, 288J, 301D, 305A, 343B, 347E, 349D, 350B, 367D, 369B, 380A, 386A, 388A; and 2) authorize the Finance Director and/or County Manager to appropriate bond proceed investment income to pay arbitrage rebate liabilities to the IRS and transfer any excess investment earnings on bond proceeds not needed for arbitrage rebate payments accumulated in capital projects to the debt service funds to be spent on interest payments due.

PRIOR BOARD ACTIONS:

Capital Project Ordinances were previously approved by the BOCC at various times for projects funded from the 2019C and 2022 General Obligation Bond Issuances.

BACKGROUND:

Arbitrage in tax-exempt bonds is the profit earned by investing proceeds from tax-exempt bonds into higher-yielding taxable investments compared to the interest rate being paid on the bonds debt service payments. Because this exploits the lower interest rates allowed by tax-exempt status, bond issuers must generally rebate these excess earnings back to the IRS. This regulation prevents governments from over-issuing debt just for profit.

Unspent tax-exempt bond proceeds are subject to IRS tax exempt bond arbitrage rebate calculations on an annual basis until all bond proceeds have been spent in full. To mitigate the continuation of annual arbitrage rebate calculations and to reduce any payments due to the IRS the Finance Director is recommending replacing the funding sources on expenditures already paid on projects with the same function as the originally adopted projects to progress the spenddown of bond proceeds in a timelier fashion.

The capital project ordinances will swap funding sources, correct funding sources or close out unneeded funds on the following projects:

Public Safety; Radio Towers, Bi-Directional Antennas at UCPS, E911 TDMA P25, Sheriff's Office Administration Building;

Library; Southwest Regional Library;

General Government; Board of Elections Renovation, UC Jail Block Renovations, UC Jail Land Purchase, Historic Courthouse House Renovations Phase 1 and 2, Government Center Building Repairs, Government Center Electrical Infrastructure, Government County Facility Repairs, and UC Progress Building;

Parks and Recreation; Paving, JHP Park Amenities, JHP Lighting, Cane Creek and P&R R&R;

Community College; SPCC Campus Improvements, SPCC Camera, SPCC Technology, and SPCC Access Controls.

FINANCIAL IMPACT:

No change in funding. The rebate payments due back to the IRS are paid for through investment earnings on the bond proceeds in the bond construction bank accounts. No county dollars are required to cover the rebate payments due to the IRS. This action has the potential to reduce increased arbitrage rebates overtime.

UNION COUNTY, NORTH CAROLINA
2025-2026
CAPITAL PROJECT ORDINANCE #211A

NOW, THEREFORE BE IT ORDAINED BY THE BOARD OF COUNTY COMMISSIONERS OF UNION COUNTY, NORTH CAROLINA:

Section I. That for the purpose of providing funds, together with any other previously appropriated available funds, for the following projects:

Historic Courthouse Phase I

Including the acquisition and construction of new facilities, the acquisition and installation of necessary furnishings and equipment, and the acquisition of interests in real property as required, project funding is hereby reduced by \$140,848, resulting in a revised total project cost of \$1,849,655.

Section II. That it is estimated that the following revenues will be available during the construction period to meet the appropriations in Section I, as set forth in the following schedule:

Transfer from General Fund	\$ 1,849,655
----------------------------	--------------

Section III. The attached CPO #211A chart is incorporated herein showing appropriations to date, additions as of this capital project ordinance, and total appropriation.

Section IV. That the finance officer is authorized from time to time to transfer as a loan from the General Fund or unspent County proceeds in the Capital Projects Funds, cash in an amount necessary to meet obligations until such time as financing is arranged, at which time repayment will be made and the finance officer is authorized to sign the Declaration of Official Intent to Reimburse Expenditures as required by Internal Revenue Service regulations.

Section V. That the finance officer is authorized at the time of project completion to close out the capital project and remove it from the general ledger.

Section VI. This capital project ordinance is adopted and effective this 4th day of May 2026.

ATTEST:

Lynn G. West,
Clerk to the Board

Chair, Union County Board of
Commissioners

CAPITAL PROJECT ORDINANCE AMENDMENT

BUDGET General CIP Fund
 FISCAL YEAR FY 2026

REQUESTED BY Beverly Liles
 DATE May 4, 2026

PROJECT SOURCES

Source Description and Code	Project To Date	Requested Amendment	Revised Project
IFT from General Fund	1,990,503	(140,848)	1,849,655
Total	1,990,503	(140,848)	1,849,655

PROJECT USES

Project Description and Code	Project To Date	Requested Amendment	Revised Project
Historic Courthouse Ph I	1,990,503	(140,848)	1,849,655
Total	1,990,503	(140,848)	1,849,655

EXPLANATION: Change in funding sources to reduce future arbitrage rebate liabilities.

DATE: 5/4/2026

APPROVED BY: _____
 Bd of Comm/County Manager
 Lynn West/Clerk to the Board

FOR FINANCE POSTING PURPOSES ONLY

PROJECT SOURCES

Source Description and Code	Project To Date	Requested Amendment	Revised Project
IFT From General Fund 40080062-4010	1,990,503	(140,848)	1,849,655
Total	1,990,503	(140,848)	1,849,655

PROJECT USES

Project Description and Code	Project To Date	Requested Amendment	Revised Project
Buildings and Improvements 40080062-5580	1,915,503	(140,848)	1,774,655
Professional Services 40080062-5381	75,000		75,000
Total	1,990,503	(140,848)	1,849,655

Prepared By EC
 Posted By _____
 Date _____

Number CPO - 211A

UNION COUNTY, NORTH CAROLINA
2025-2026
CAPITAL PROJECT ORDINANCE #239B

NOW, THEREFORE BE IT ORDAINED BY THE BOARD OF COUNTY COMMISSIONERS OF UNION COUNTY, NORTH CAROLINA:

Section I. That for the purpose of providing funds, together with any other previously appropriated available funds, for the following projects:

Radio Towers – SW Union

Including the replacement of equipment, the acquisition and construction of new facilities, the acquisition and installation of necessary furnishings and equipment, and the acquisition of interests in real property as required, this amendment appropriates a funding source change within the project by reducing bond proceeds in the amount of \$1,156,353 and increasing the transfer from the General Fund by the same amount, resulting in no net change to the total project cost of \$2,220,335.

Section II. That it is estimated that the following revenues will be available during the construction period to meet the appropriations in Section I, as set forth in the following schedule:

Transfer from General Fund	\$1,156,353
GO Bond Proceeds	\$1,063,982

Section III. The attached CPO #239B chart is incorporated herein showing appropriations to date, additions as of this capital project ordinance, and the total appropriation.

Section IV. That the finance officer is authorized from time to time to transfer as a loan from the General Fund or unspent County proceeds in the Capital Projects Funds, cash in an amount necessary to meet obligations until such time as financing is arranged, at which time repayment will be made and the finance officer is authorized to sign the Declaration of Official Intent to Reimburse Expenditures as required by Internal Revenue Service regulations.

Section V. That the finance officer is authorized at the time of project completion to close out the capital project and remove it from the general ledger.

Section VI. This capital project ordinance is adopted and effective this 4th day of May 2026.

ATTEST:

Lynn G. West,
Clerk to the Board

Chair, Union County Board of Commissioners

CAPITAL PROJECT ORDINANCE AMENDMENT

BUDGET General CPO
 FISCAL YEAR FY 2026

REQUESTED BY Beverly Liles
 DATE May 4, 2026

PROJECT SOURCES

Source Description and Code	Project To Date	Requested Amendment	Revised Project
IFT from General Fund	-	1,156,353	1,156,353
GO Bond Proceeds	2,220,335	(1,156,353)	1,063,982
Total	2,220,335	-	2,220,335

PROJECT USES

Project Description and Code	Project To Date	Requested Amendment	Revised Project
Radio Towers	2,220,335	-	2,220,335
			-
Total	2,220,335	-	2,220,335

EXPLANATION: Transfer fundings sources on the Radio Tower project to reduce arbitrage rebate liabilities.

DATE: _____

APPROVED BY: _____
 Bd of Comm/County Manager
 Lynn West/Clerk to the Board

FOR FINANCE POSTING PURPOSES ONLY

PROJECT SOURCES

Source Description and Code	Project To Date	Requested Amendment	Revised Project
40080105-4010 <i>IFT from General Fund</i>	-	1,156,353	1,156,353
40080105-4717 <i>GO Bond Proceeds Premiums</i>	2,220,335	(1,156,353)	1,063,982
Total	2,220,335	-	2,220,335

PROJECT USES

Project Description and Code	Project To Date	Requested Amendment	Revised Project
40080105-5550 Radio Towers	2,220,335	-	2,220,335
Total	2,220,335	-	2,220,335

Prepared By EC
 Posted By _____
 Date _____

Number CPO - 239B

UNION COUNTY, NORTH CAROLINA
2025-2026
CAPITAL PROJECT ORDINANCE #254A

NOW, THEREFORE BE IT ORDAINED BY THE BOARD OF COUNTY COMMISSIONERS OF UNION COUNTY, NORTH CAROLINA:

Section I. That for the purpose of providing funds, together with any other previously appropriated available funds, for the following projects:

County Facility Repairs
CC Park Campground R&R
P&R R&R FY2020

Including the acquisition and construction of new facilities, the acquisition and installation of necessary furnishings and equipment, and the acquisition of interests in real property as required, funding is hereby reallocated within the project by decreasing transfers from the General Fund in the amount of \$2,096,125 and increasing bond proceeds by the same amount, resulting in no change to the total project cost of \$2,496,649.

Section II. That it is estimated that the following revenues will be available during the construction period to meet the appropriations in Section I, as set forth in the following schedule:

Transfer from General Fund	\$400,524
General Obligation Bond Proceeds	\$2,096,125

Section III. The attached CPO #254A chart is incorporated herein showing appropriations to date, additions as of this capital project ordinance, and the total appropriation.

Section IV. That the finance officer is authorized from time to time to transfer as a loan from the General Fund or unspent County proceeds in the Capital Projects Funds, cash in an amount necessary to meet obligations until such time as financing is arranged, at which time repayment will be made and the finance officer is authorized to sign the Declaration of Official Intent to Reimburse Expenditures as required by Internal Revenue Service regulations.

Section V. That the finance officer is authorized at the time of project completion to close out the capital project and remove it from the general ledger.

Section VI. This capital project ordinance is adopted and effective this 4th day of May 2026.

ATTEST:

Lynn G. West, Clerk to the Board

Chair, Union County Board of
Commissioners

UNION COUNTY, NORTH CAROLINA
2025-2026
CAPITAL PROJECT ORDINANCE #273B

NOW, THEREFORE BE IT ORDAINED BY THE BOARD OF COUNTY COMMISSIONERS OF UNION COUNTY, NORTH CAROLINA:

Section I. That for the purpose of providing funds, together with any other previously appropriated available funds, for the following projects:

Sheriff's Office Expansion

Including the replacement of equipment, the acquisition and construction of new facilities, the acquisition and installation of necessary furnishings and equipment, and the acquisition of interests in real property as required, this amendment appropriates a funding source change within the project by reducing bond proceeds in the amount of \$330,742 and increasing the transfer from the General Fund by the same amount, resulting in no net change to the total project cost of \$27,592,166.

Section II. That it is estimated that the following revenues will be available during the construction period to meet the appropriations in Section I, as set forth in the following schedule:

Transfer from General Fund	\$460,742
GO Bond Proceeds	\$26,969,274
Investment Earnings from Bond Proceeds	\$162,150

Section III. The attached CPO #273B chart is incorporated herein showing appropriations to date, additions as of this capital project ordinance, and the total appropriation.

Section IV. That the finance officer is authorized from time to time to transfer as a loan from the General Fund or unspent County proceeds in the Capital Projects Funds, cash in an amount necessary to meet obligations until such time as financing is arranged, at which time repayment will be made and the finance officer is authorized to sign the Declaration of Official Intent to Reimburse Expenditures as required by Internal Revenue Service regulations.

Section V. That the finance officer is authorized at the time of project completion to close out the capital project and remove it from the general ledger.

Section VI. This capital project ordinance is adopted and effective this 4th day of May 2026.

ATTEST:

Lynn G. West,
Clerk to the Board

Chair, Union County Board of Commissioners

CAPITAL PROJECT ORDINANCE AMENDMENT

BUDGET General CIP REQUESTED BY Beverly Liles
 FISCAL YEAR FY 2026 DATE May 4, 2026

PROJECT SOURCES

Source Description and Code	Project To Date	Requested Amendment	Revised Project
IFT from General Fund	130,000	330,742	460,742
General Obligation Bond Proceeds	27,300,016	(330,742)	26,969,274
Investment Earnings from Bond Proceeds	162,150	-	162,150
Total	27,592,166	-	27,592,166

PROJECT USES

Project Description and Code	Project To Date	Requested Amendment	Revised Project
Sheriff's Office Expansion	27,592,166	-	27,592,166
Total	27,592,166	-	27,592,166

EXPLANATION: Change funding source to reduce future arbitrage rebate liabilities.

DATE: _____

APPROVED BY: _____

Bd of Comma/County Manager
Lynn West/Clerk to the Board

FOR FINANCE POSTING PURPOSES ONLY

PROJECT SOURCES

Source Description and Code	Project To Date	Requested Amendment	Revised Project
Sheriff's Office Expansion			
IFT from General Fund 40080080-4010	130,000	330,742	460,742
GO Bond Proceeds 40080080-4710	27,300,016	(330,742)	26,969,274
Investment Earnings from Bond Proceeds 40080080-4812	162,150	-	162,150
Total	27,592,166	-	27,592,166

PROJECT USES

Project Description and Code	Project To Date	Requested Amendment	Revised Project
Sheriff's Office Expansion			
Professional Services 40080080-5381	80,000	-	80,000
Buildings and Improvements 40080080-5580	27,512,166	-	27,512,166
Total	27,592,166	-	27,592,166

Prepared By EC
 Posted By _____
 Date _____

Number CPO - 273B

UNION COUNTY, NORTH CAROLINA
2025-2026
CAPITAL PROJECT ORDINANCE #277B

NOW, THEREFORE BE IT ORDAINED BY THE BOARD OF COUNTY COMMISSIONERS OF UNION COUNTY, NORTH CAROLINA:

Section I. That for the purpose of providing funds, together with any other previously appropriated available funds, for the following projects:

BOE Renovations

Including the acquisition and construction of new facilities, the acquisition and installation of necessary furnishings and equipment, and the acquisition of interests in real property as required, the sum of \$152,640 is hereby reduced, resulting in a revised total project cost of \$4,725,034.

Section II. That it is estimated that the following revenues will be available during the construction period to meet the appropriations in Section I, as set forth in the following schedule:

Transfer from General Fund	\$23,918
General Obligation Bond Proceeds	\$4,525,000
General Obligation Bond Proceeds Premiums	\$73,442
Investment Earnings	\$102,674

Section III. The attached CPO #277B chart is incorporated herein showing appropriations to date, additions as of this capital project ordinance, and the total appropriation.

Section IV. That the finance officer is authorized from time to time to transfer as a loan from the General Fund or unspent County proceeds in the Capital Projects Funds, cash in an amount necessary to meet obligations until such time as financing is arranged, at which time repayment will be made and the finance officer is authorized to sign the Declaration of Official Intent to Reimburse Expenditures as required by Internal Revenue Service regulations.

Section V. That the finance officer is authorized at the time of project completion to close out the capital project and remove it from the general ledger.

Section VI. This capital project ordinance is adopted and effective this 4th day of May 2026.

ATTEST:

Lynn G. West, Clerk to the Board

Chair, Union County Board of
Commissioners

CAPITAL PROJECT ORDINANCE AMENDMENT

BUDGET General CIP Fund
 FISCAL YEAR FY 2026

REQUESTED BY Beverly Liles
 DATE May 4, 2026

PROJECT SOURCES

Source Description and Code	Project To Date	Requested Amendment	Revised Project
IFT from General Fund	100,000	(76,082)	23,918
GO Bond Proceeds	4,525,000	-	4,525,000
Invest Earnings -Debt Funds	102,674	-	102,674
GO Bond Proceeds Premiums	150,000	(76,558)	73,442
Total	4,877,674	(152,640)	4,725,034

PROJECT USES

Project Description and Code	Project To Date	Requested Amendment	Revised Project
BOE Renovations	4,877,674	(152,640)	4,725,034
Total	4,877,674	(152,640)	4,725,034

EXPLANATION: Changes in funding sources to reduce future arbitrage rebate liabilities.

DATE: 5/4/2026

APPROVED BY: _____
 Bd of Comma/County Manager
 Lynn West/Clerk to the Board

FOR FINANCE POSTING PURPOSES ONLY

PROJECT SOURCES

Source Description and Code	Project To Date	Requested Amendment	Revised Project
BOE Renovations IFT from General Fund 40080107-4010	100,000	(76,082)	23,918
GO Bond Proceeds 40080107-4710	4,525,000	-	4,525,000
Investment Earnings 40080107-4812	102,674	-	102,674
GO Bond Proceeds Premiums 40080107-4717	150,000	(76,558)	73,442
Total	4,877,674	(152,640)	4,725,034

PROJECT USES

Project Description and Code	Project To Date	Requested Amendment	Revised Project
BOE Renovations Building and Improvements 40080107-5580	4,877,674	(152,640)	4,725,034
Total	4,877,674	(152,640)	4,725,034

Prepared By EC
 Posted By _____
 Date _____

Number CPO - 277B

UNION COUNTY, NORTH CAROLINA
2025-2026
CAPITAL PROJECT ORDINANCE #283C

NOW, THEREFORE BE IT ORDAINED BY THE BOARD OF COUNTY COMMISSIONERS OF UNION COUNTY, NORTH CAROLINA:

Section I. That for the purpose of providing funds, together with any other available funds, for the following projects:

Annual Operating R&R Projects

- Facilities Operating Capital
- Facilities Replacement & Renewal
- UCSO Operating Capital
- UCSO Replacement & Renewal
- Parks and Rec Replacement & Renewal
- Cane Creek Campground
- Library Replacement & Renewal
- SPCC Maintenance
- SPCC Technology
- SPCC HVAC, Security, Other

Including the acquisition and construction of new facilities, the acquisition and installation of necessary furnishings and equipment, and the acquisition of interests in real property as required, funding is hereby reallocated within the project by decreasing transfers from the General Fund in the amount of \$225,000 and increasing bond proceeds by the same amount, resulting in no change to the total project cost of \$2,078,351.

Section II. That it is estimated that the following revenues will be available during the construction period to meet the appropriations in Section I, as set forth in the following schedule:

Interfund Transfer from:	
General Fund	\$ 1,853,351
GO Bond Proceeds	\$ 225,000

Section III. The attached CPO #283C chart is incorporated herein showing appropriations to date, additions as of this capital project ordinance, and the total appropriation.

Section IV. That the finance officer is authorized from time to time to transfer as a loan from the General Fund or unspent County proceeds in the Capital Projects Funds, cash in an amount necessary to meet obligations until such time as financing is arranged, at which time repayment will be made and the finance officer is authorized to sign the Declaration of Official Intent to Reimburse Expenditures as required by Internal Revenue Service regulations.

Section V. This capital project ordinance is adopted and effective this 4th day of May 2026.

ATTEST:

Lynn G. West,
Clerk to the Board

Chair, Union County Board of
Commissioners

CAPITAL PROJECT ORDINANCE AMENDMENT

BUDGET General CIP Fund
 FISCAL YEAR FY 2026

REQUESTED BY Beverly Liles
 DATE May 4, 2026

PROJECT SOURCES

Source Description and Code	Project To Date	Requested Amendment	Revised Project
IFT from General Fund	2,078,351	(225,000)	1,853,351
GO Bond Proceeds	-	225,000	225,000
			-
Total	2,078,351	-	2,078,351

PROJECT USES

Project Description and Code	Project To Date	Requested Amendment	Revised Project
R&R projects for General Capital	1,703,351	-	1,703,351
R&R projects for SPCC	375,000	-	375,000
			-
Total	2,078,351	-	2,078,351

EXPLANATION: Changes in funding source to reduce future arbitrage liabilities.

DATE: 5/4/2026

APPROVED BY: _____
 Bd of Comma/County Manager
 Lynn West/Clerk to the Board

FOR FINANCE POSTING PURPOSES ONLY

PROJECT SOURCES

Source Description and Code	Project To Date	Requested Amendment	Revised Project
Facilities Operating Capital			
IFT from General Fund 40080131-4010-52022	518,351	-	518,351
Facilities Replacement & Renewal			
IFT from General Fund 40080069-4010-52022	685,000	-	685,000
UCSO Operating Capital			
IFT from General Fund 40080132-4010-52022	150,000	-	150,000
UCSO Replacement & Renewal			
IFT from General Fund 40080135-4010-52022	100,000	-	100,000
Parks and Rec Replacement & Renewal			
IFT from General Fund 40080134-4010-52022	125,000	(125,000)	-
GO Bonds Proceeds 40080134-4710-52022	-	125,000	125,000
Cane Creek Campground			
IFT from General Fund 40080120-4010-52022	100,000	(100,000)	-
GO Bonds Proceeds 40080120-4710-52022	-	100,000	100,000
Library Replacement & Renewal			
IFT from General Fund 40080130-4010-52022	25,000	-	25,000
SPCC Maintenance			
IFT from General Fund 40080067-4010-52022	100,000	-	100,000
SPCC Technology			
IFT from General Fund 40080076-4010-52022	175,000	-	175,000
SPCC HVAC, Security, Other			
IFT from General Fund 40080077-4010-52022	100,000	-	100,000
Total	2,078,351	-	2,078,351

PROJECT USES

Project Description and Code	Project To Date	Requested Amendment	Revised Project
Facilities Operating Capital			
Building & Improvements 40080131-5580-52022	518,351	-	518,351
Facilities Replacement & Renewal			
Building & Improvements 40080069-5580-52022	685,000	-	685,000
UCSO Operating Capital			
Building & Improvements 40080132-5580-52022	150,000	-	150,000
UCSO Replacement & Renewal			
Building & Improvements 40080135-5580-52022	100,000	-	100,000
Parks and Rec Replacement & Renewal			
Building & Improvements 40080134-5580-52022	125,000	-	125,000
Cane Creek Campground			
Building & Improvements 40080120-5580-52022	100,000	-	100,000
Library Replacement & Renewal			
Building & Improvements 40080130-5580-52022	25,000	-	25,000
SPCC Maintenance			
Payment to Other Gov't Agencies 40080067-5630-52022	100,000	-	100,000
SPCC Technology			
Payment to Other Gov't Agencies 40080076-5630-52022	175,000	-	175,000
SPCC HVAC, Security, Other			
Payment to Other Gov't Agencies 40080077-5630-52022	100,000	-	100,000
Total	2,078,351	-	2,078,351

Prepared By EC
 Posted By _____
 Date _____

Number CPO - 283C

UNION COUNTY, NORTH CAROLINA
2025-2026
CAPITAL PROJECT ORDINANCE #284D

NOW, THEREFORE BE IT ORDAINED BY THE BOARD OF COUNTY COMMISSIONERS OF UNION COUNTY, NORTH CAROLINA:

Section I. That for the purpose of providing funds, together with any other available funds, for the following projects:

Critical Infrastructure Projects

- Agriculture Center - Generator & Infrastructure
- Government Center - Electrical Improvements
- UPS Infrastructure Upgrades and Replacements
- Radio Towers - HVAC System Replacement (6 Towers)
- UC Public Schools Administration Building - Replace Generator
- Judicial Center - Generator Replacement
- Animal Shelter - Replace UPS System
- Government Center - Replace Liebert Unit 3rd Floor Server Room
- Judicial Center - Server Room Split System Renewal

Including the replacement of equipment, the acquisition and construction of new facilities, the acquisition and installation of necessary furnishings and equipment, and the acquisition of interests in real property as required, this amendment appropriates a funding source change within the project by decreasing the transfers from the General Fund in the amount of \$399,305 and increasing bond proceeds by the same amount, with no change to the total project cost of \$1,885,649.

Section II. That it is estimated that the following revenues will be available during the construction period to meet the appropriations in Section I, as set forth in the following schedule:

Interfund Transfer from:	
General Fund	\$1,885,649

Section III. The attached CPO #284D chart is incorporated herein showing appropriations to date, additions as of this capital project ordinance, and the total appropriation.

Section IV. That the finance officer is authorized from time to time to transfer as a loan from the General Fund or unspent County proceeds in the Capital Projects Funds, cash in an amount necessary to meet obligations until such time as financing is arranged, at which time repayment will be made and the finance officer is authorized to sign the Declaration of Official Intent to Reimburse Expenditures as required by Internal Revenue Service regulations.

Section V. This capital project ordinance is adopted and effective this 4th day of May 2026.

ATTEST:

Lynn G. West, Clerk to the Board
Commissioners

Chairman, Union County Board of

CAPITAL PROJECT ORDINANCE AMENDMENT

BUDGET General CIP Fund
 FISCAL YEAR FY 2026

REQUESTED BY Beverly Liles
 DATE May 4, 2026

PROJECT SOURCES

Source Description and Code	Project To Date	Requested Amendment	Revised Project
IFT from General Fund	1,885,649	-	1,885,649
			-
			-
Total	1,885,649	-	1,885,649

PROJECT USES

Project Description and Code	Project To Date	Requested Amendment	Revised Project
General Fund Critical Infrastructure Needs	1,885,649	-	1,885,649
			-
			-
Total	1,885,649	-	1,885,649

EXPLANATION: Changes to funding sources to reduce future arbitrage rebate liabilities.

DATE: 5/4/2026

APPROVED BY: _____
 Bd of Comma/County Manager
 Lynn West/Clerk to the Board

FOR FINANCE POSTING PURPOSES ONLY

PROJECT SOURCES

Source Description and Code	Project To Date	Requested Amendment	Revised Project
Agriculture Center - Generator & Infrastructure			
IFT From General Fund 40080146-4010	350,000	-	350,000
Government Center - Electrical Improvements			
IFT From General Fund 40080142-4010	1,040,000	(399,305)	640,695
GO Bond Proceeds 40080142-4710	-	399,305	399,305
UPS Infrastructure Upgrades and Replacements			
IFT From General Fund 40080168-4010	150,000	-	150,000
Radio Towers - HVAC System Replacement (6 Towers)			
IFT From General Fund 40080169-4010	64,000	-	64,000
UC Public Schools - Replace Generator			
IFT From General Fund 40080174-4010	121,649	-	121,649
Judicial Center - Generator Replacement			
IFT From General Fund 40080170-4010	-	-	-
Animal Shelter - Replace UPS System			
IFT From General Fund 40080171-4010	30,000	-	30,000
Government Center - Replace Liebert Unit 3rd Floor Server Room			
IFT From General Fund 40080147-4010	40,000	-	40,000
Judicial Center - Server Room Split System Renewal			
IFT From General Fund 40080172-4010	90,000	-	90,000
Total	1,885,649	-	1,885,649

PROJECT USES

Project Description and Code	Project To Date	Requested Amendment	Revised Project
Agriculture Center - Generator & Infrastructure			
Building & Improvements 40080146-5580	350,000	-	350,000
Government Center - Electrical Improvements			
Building & Improvements 40080142-5580	1,040,000	-	1,040,000
UPS Infrastructure Upgrades and Replacements			
Other Equipment 40080168-5550	150,000	-	150,000
Radio Towers - HVAC System Replacement (6 Towers)			
Other Equipment 40080169-5550	64,000	-	64,000
UC Public Schools - Replace Generator			
Other Equipment 40080174-5550	121,649	-	121,649
Judicial Center - Generator Replacement			
Other Equipment 40080170-5550	-	-	-
Animal Shelter - Replace UPS System			
Other Equipment 40080171-5550	30,000	-	30,000
Government Center - Replace Liebert Unit 3rd Floor Server Room			
Building & Improvements 40080147-5580	40,000	-	40,000
Judicial Center - Server Room Split System Renewal			
Other Equipment 40080172-5550	90,000	-	90,000
Total	1,885,649	-	1,885,649

Prepared By EC
 Posted By _____
 Date _____

Number CPO - 284D

**UNION COUNTY, NORTH CAROLINA
MAJOR INFRASTRUCTURE – 2025-2026
CAPITAL PROJECT ORDINANCE #288J**

NOW, THEREFORE BE IT ORDAINED BY THE BOARD OF COUNTY COMMISSIONERS OF UNION COUNTY, NORTH CAROLINA:

Section I. That for the purpose of providing funds, together with any other available funds, for the following projects:

Major Infrastructure Projects

- Union County Lock Project Enhancements
- Union County Jail Block Renovations
- Union County Three Commercial Washer & Dryer Replacement
- Government Center/Judicial – Building Envelope Repairs
- UC Progress Building Renovations
- Parks and Recreation Paving
- Jesse Helms Park- Park Amenities Improvements
- Historic Courthouse Phase 2 Renovation
- Main Library Replace Metal Architectural Panels
- Cane Creek Park Camp Store
- Patton Avenue Radio Shop Renovation
- SPCC Building A Renovation Needs
- SPCC Camera System
- SPCC Access Controls

Including the replacement of equipment, the acquisition and construction of new facilities, the acquisition and installation of necessary furnishings and equipment and the acquisition of interests in real property required therefore, a reduction of \$413,028 is hereby appropriated for total project cost of \$30,153,665.

Section II. That it is estimated that the following revenues will be available during the construction period to meet the appropriations in Section I, as set forth in the following schedule:

Federal Grant	\$104,936
2/3rd GO Bond Proceeds	\$14,823,203
2/3rd GO Bond Proceeds Premiums	\$775,678
Investment Earnings	\$229,381
Interfund Transfer from General Fund	\$5,079,411
Interfund Transfer from EMS Fund	\$100,000
Previous GO Bond Proceeds	\$3,489,380
Installment Financing Proceeds	\$5,551,676

Section III. The attached CPO #288J chart is incorporated herein showing appropriations to date, additions as of this capital project ordinance, and the total appropriation.

Section IV. That the finance officer is authorized from time to time to transfer as a loan from the General Fund or unspent County proceeds in the Capital Projects Funds, cash in an amount necessary to meet obligations until such time as financing is arranged, at which time repayment will be made and the finance officer is authorized to sign the Declaration of Official Intent to Reimburse Expenditures as required by Internal Revenue Service regulations.

Section V. This capital project ordinance is adopted and effective on the 4th day of May 2026.

ATTEST:

Lynn G. West,
Clerk to the Board

Chair, Union County Board of
Commissioners

CAPITAL PROJECT ORDINANCE AMENDMENT

BUDGET General CIP Fund
 FISCAL YEAR FY 2026

REQUESTED BY Beverly Liles
 DATE May 4, 2026

PROJECT SOURCES

Source Description and Code	Project To Date	Requested Amendment	Revised Project
Intergovernmental Revenue	240,000	(240,000)	-
Federal Grant	104,936	-	104,936
2/3rd Go Bond Proceeds	14,823,203	-	14,823,203
2/3rd Go Bond Proceeds Premiums	775,678	-	775,678
IFT From General Fund	2,059,855	3,019,556	5,079,411
IFT From General Fund/Old EMS Fund	100,000	-	100,000
Previous Go Bond Proceeds	6,900,000	(3,410,620)	3,489,380
Installment Financing Proceeds	5,551,676	-	5,551,676
Investment Earnings	11,345	218,036	229,381
Total	30,566,693	(413,028)	30,153,665

PROJECT USES

Project Description and Code	Project To Date	Requested Amendment	Revised Project
General Fund Major Infrastructure Needs	18,939,513	(413,028)	18,526,485
SPCC Major Infrastructure Needs	11,627,180	-	11,627,180
Total	30,566,693	(413,028)	30,153,665

EXPLANATION: Change in funding sources to reduce future arbitrage liabilities.

DATE: 5/4/2026

APPROVED BY: _____

BOCC/County Manager
 Lynn West/Clerk to the Board

FOR FINANCE POSTING PURPOSES ONLY

PROJECT SOURCES

Source Description and Code	Project To Date	Requested Amendment	Revised Project
UC Jail - Door Locks and Controls			
IFT From General Fund	1,170,000	-	1,170,000
40080126-4010			
GO Bond Proceeds	1,585,000	-	1,585,000
40080126-4710			
GO Bond Proceeds Premiums	390,848	-	390,848
40080126-4717			
Investment Earnings	11,345	-	11,345
40080126-4812			
UC Jail - Block Renovations			
IFT From General Fund	-	824,196	824,196
40080112-4010			
GO Bond Proceeds	1,615,000	(1,378,072)	236,928
40080112-4710			
Parks and Recreation Paving			
IFT From General Fund	-	232,460	232,460
40080075-4010			
GO Bond Proceeds	232,460	(232,460)	-
40080075-4710			
Historic Courthouse - Phase 2 Renovation			
IFT From General Fund	-	1,811,709	1,811,709
40080125-4010			
GO Bond Proceeds	1,725,000	(1,670,861)	54,139
40080125-4710			
Jesse Helms Park - Park Amenities Improvements			
GO Bond Proceeds	-	480,500	480,500
40080167-4010			
GO Bond Proceeds	500,000	(480,500)	19,500
40080167-4710			
Main Library - Replace Metal Architectural Panels			
GO Bond Proceeds	568,000	-	568,000
40080156-4710			
GO Bond Proceeds Premiums	74,712	-	74,712
40080156-4717			
IFT From General Fund	215,000	-	215,000
40080156-4010			
Cane Creek Park - New Camp Store			
GO Bond Proceeds	850,000	-	850,000
40080100-4710			
GO Bond Proceeds Premiums	100,000	-	100,000
40080100-4717			
Patton Avenue - Radio Shop Renovation			
IFT From General Fund	58,455	-	58,455
40080160-4010			
GO Bond Proceeds	935,000	-	935,000
40080160-4710			
UC Jail - Replace 3 Commercial Washers And Dryers			
GO Bond Proceeds	299,963	-	299,963
40080173-4710			
IFT From EMS Fund	100,000	-	100,000
40080173-4020			
Government Center/Judicial Center - Building Envelope Repairs - Phase 1 + 2			
IFT From General Fund	250,000	662,935	912,935

PROJECT USES

Project Description and Code	Project To Date	Requested Amendment	Revised Project
UC Jail - Door Locks and Controls			
Building & Improvements	3,157,193	-	3,157,193
40080126-5580			
UC Jail - Block Renovations			
Building & Improvements	1,615,000	(553,876)	1,061,124
40080112-5580			
Parks and Recreation Paving			
Land and Improvements	232,460	-	232,460
40080075-5570			
Historic Courthouse - Phase 2 Renovation			
Building & Improvements	1,725,000	140,848	1,865,848
40080125-5580			
Jesse Helms Park - Park Amenities Improvements			
Building & Improvements	500,000	-	500,000
40080167-5580			
Main Library - Replace Metal Architectural Panels			
Building & Improvements	857,712	-	857,712
40080156-5580			
Cane Creek Park - New Camp Store			
Building & Improvements	950,000	-	950,000
40080100-5580			
Patton Avenue - Radio Shop Renovation			
Other Equipment	993,455	-	993,455
40080160-5550			
UC Jail - Replace 3 Commercial Washers And Dryers			
Other Equipment	399,963	-	399,963
40080173-5550			
Government Center/Judicial Center - Building Envelope Repairs - Phase 1 + 2			
Building & Improvements	1,600,000	-	1,600,000

40080123-4010				40080123-5580			
GO Bond Proceeds	1,350,000	(662,935)	687,065				
40080123-4710							
UC Progress Building				UC Progress Building			
GO Bond Proceeds	675,000	301,248	976,248	Building & Improvements	6,777,560	-	6,777,560
40080159-4710				40080159-5580			
Installment Financing Proceeds	5,551,676	-	5,551,676	Building & Improvements	131,170	-	131,170
40080159-4730				40080159-5260-14022			
Intergovernmental Revenue	240,000	(240,000)	-				
40080159-4280							
IFT From General Fund	100,766	(61,248)	39,518				
40080159-4010							
GO Bond Proceeds Premiums	210,118	-	210,118				
40080159-4717							
Federal Grant	104,936	-	104,936				
40080159-4315-14022							
IFT From General Fund	26,234	-	26,234				
40080159-4010-14022							
SPCC Building A Renovation Needs				SPCC Building A Renovation Needs			
GO Bond Proceeds	10,740,000	-	10,740,000	Payments to Other Governments	10,740,000	-	10,740,000
40080093-4710				40080093-5630			
SPCC Camera System				SPCC Camera System			
IFT From General Fund	218,036	(218,036)	-	Payments to Other Governments	218,036	-	218,036
40080161-4010				40080161-5630			
Investment Earnings	-	218,036	218,036				
40080161-4812							
SPCC Access Controls				SPCC Access Controls			
IFT From General Fund	21,364	-	21,364	Payments to Other Governments	669,144	-	669,144
40080162-4010				40080162-5630			
GO Bond Proceeds	647,780	-	647,780				
40080162-4710							
Total	30,566,693	(413,028)	30,153,665	Total	30,566,693	(413,028)	30,153,665

Prepared By EC
 Posted By _____
 Date _____

Number CPO - 288J

UNION COUNTY, NORTH CAROLINA
2025-2026
CAPITAL PROJECT ORDINANCE #301D

NOW, THEREFORE BE IT ORDAINED BY THE BOARD OF COUNTY COMMISSIONERS OF UNION COUNTY, NORTH CAROLINA:

Section I. That for the purpose of providing funds, together with any other available funds, for the following projects:

Southwest Regional Library

Including the purchase of equipment and software, the acquisition, expansion, and construction of new facilities, the acquisition and installation of necessary furnishings and equipment, and the acquisition of interests in real property as required, investment earnings on bond proceeds are hereby increased by \$81,503 and donations are hereby reduced by \$300,000, resulting in total appropriations of \$14,598,917.

Section II. That it is estimated that the following revenues will be available until completion of these projects to meet the appropriations in Section I, as set forth in the following schedule:

Transfer from General Fund	\$ 3,500,000
North Carolina State Grant	\$ 300,000
GO Bond Proceeds	\$10,310,000
GO Bond Proceeds Premium	\$ 192,500
Invest Earnings on Bond Proceeds	\$ 296,417

Section III. The attached CPO #301D chart is incorporated herein showing appropriations to date, additions as of this capital project ordinance, and the total appropriation.

Section IV. That the finance officer is authorized from time to time to transfer as a loan from the General Fund or unspent County proceeds in the Capital Projects Funds, cash in an amount necessary to meet obligations until such time as financing is arranged, at which time repayment will be made and the finance officer is authorized to sign the Declaration of Official Intent to Reimburse Expenditures as required by Internal Revenue Service regulations.

Section V. That the finance officer is authorized at the time of project completion to close out the capital project and remove it from the general ledger.

Section VI. This capital project ordinance is adopted and effective this 4th day of May 2026.

ATTEST:

Lynn G. West, Clerk to the Board

Chair, Union County Board of
Commissioners

CAPITAL PROJECT ORDINANCE AMENDMENT

BUDGET General Capital Project Fund
 FISCAL YEAR FY 2026

REQUESTED BY Beverly Liles
 DATE May 4, 2026

PROJECT SOURCES

Source Description and Code	Project To Date	Requested Amendment	Revised Project
Donations	300,000	(300,000)	-
State Grant	300,000		300,000
GO Bond Proceeds	10,310,000		10,310,000
GO Bond Proceeds Premium	192,500		192,500
Investment Earnings on Bond Proceeds	214,914	81,503	296,417
IFT from General Fund	3,500,000		3,500,000
Total	14,817,414	(218,497)	14,598,917

PROJECT USES

Project Description and Code	Project To Date	Requested Amendment	Revised Project
Southwest Regional Library	14,817,414	(218,497)	14,598,917
Total	14,817,414	(218,497)	14,598,917

EXPLANATION: Change funding source to reduce future arbitrage rebate liabilities.

DATE: 5/4/2026

APPROVED BY: _____
 BOCC Chairman/County Manager
 Lynn West/Clerk to the Board

FOR FINANCE POSTING PURPOSES ONLY

PROJECT SOURCES

Source Description and Code	Project To Date	Requested Amendment	Revised Project
Southwest Regional Library			
State Revenue	300,000	-	300,000
40080096-4431-11810			
GO Bond Proceeds	10,310,000	-	10,310,000
40080096-4710			
GO Bond Proceeds Premium	192,500	-	192,500
40080096-4717			
Investment Earnings on Bond Proceeds	214,914	81,503	296,417
40080096-4812			
IFT from General Fund	3,500,000	-	3,500,000
40080096-4010			
Donations	300,000	(300,000)	-
40080096-4840			
Total	14,817,414	(218,497)	14,598,917

PROJECT USES

Project Description and Code	Project To Date	Requested Amendment	Revised Project
Southwest Regional Library			
ARCHITECTURAL & ENGINEERING	624,892	-	624,892
40080096-5594			
PROFESSIONAL SERVICES	522,359	-	522,359
40080096-5381			
CONSTRUCTION			
40080096-5580	13,370,163	(218,497)	13,151,666
40080096-5580-11810 (State Grant)	300,000	-	300,000
Total	14,817,414	(218,497)	14,598,917

Prepared By EC
 Posted By _____
 Date _____

Number CPO - 301D

UNION COUNTY, NORTH CAROLINA
2025-2026
CAPITAL PROJECT ORDINANCE #305A

NOW, THEREFORE BE IT ORDAINED BY THE BOARD OF COUNTY COMMISSIONERS OF UNION COUNTY, NORTH CAROLINA:

Section I. That for the purpose of providing funds, together with any other available funds, for the following projects:

Annual Operating R&R Projects

- Facilities Operating Capital
- Facilities Replacement & Renewal
- UCSO Operating Capital
- UCSO Replacement & Renewal
- Parks and Rec Replacement & Renewal
- Cane Creek Campground
- SPCC Maintenance
- SPCC Technology
- SPCC HVAC, Security, Other

Including the replacement of equipment, the acquisition and construction of new facilities, the acquisition and installation of necessary furnishings and equipment, and the acquisition of interests in real property as required, this amendment provides for a reallocation of funding within the project by decreasing transfers from the General Fund in the amount of \$250,000 and increasing general obligation bond proceeds by the same amount, with no change to the total project cost of \$2,500,000.

Section II. That it is estimated that the following revenues will be available during the construction period to meet the appropriations in Section I, as set forth in the following schedule:

Interfund Transfer from:	
General Fund	\$ 2,250,000
GO Bond Proceeds	\$ 250,000

Section III. The attached CPO #305A chart is incorporated herein showing appropriations to date, additions as of this capital project ordinance, and the total appropriation.

Section IV. That the finance officer is authorized from time to time to transfer as a loan from the General Fund or unspent County proceeds in the Capital Projects Funds, cash in an amount necessary to meet obligations until such time as financing is arranged, at which time repayment will be made and the finance officer is authorized to sign the Declaration of Official Intent to Reimburse Expenditures as required by Internal Revenue Service regulations.

Section V. That the finance officer is authorized at the time of project completion to close out the capital project and remove it from the general ledger.

Section VI. This capital project ordinance is adopted and effective this 4th day of May 2026.

ATTEST:

Lynn G. West, Clerk to the Board

Chair, Union County Board of
Commissioners

CAPITAL PROJECT ORDINANCE AMENDMENT

BUDGET General CIP Fund

REQUESTED BY Beverly Liles

FISCAL YEAR FY 2026

DATE May 4, 2026

PROJECT SOURCES

Source Description and Code	Project To Date	Requested Amendment	Revised Project
IFT from General Fund	2,500,000	(250,000)	2,250,000
GO Bond Proceeds	-	250,000	250,000
Total	2,500,000	-	2,500,000

PROJECT USES

Project Description and Code	Project To Date	Requested Amendment	Revised Project
R&R projects for General Capital	2,125,000	(250,000)	1,875,000
R&R projects for SPCC	375,000	-	375,000
Total	2,500,000	(250,000)	2,250,000

EXPLANATION: Change funding sources to reduce the future arbitrage rebate liabilities.

DATE: _____

APPROVED BY: _____
Bd of Comma/County Manager
Lynn West/Clerk to the Board

FOR FINANCE POSTING PURPOSES ONLY

PROJECT SOURCES

Source Description and Code	Project To Date	Requested Amendment	Revised Project
Facilities Operating Capital			
IFT from General Fund 40080131-4010-52023	575,000	-	575,000
Facilities Replacement & Renewal			
IFT from General Fund 40080069-4010-52023	950,000	-	950,000
UCSO Operating Capital			
IFT from General Fund 40080132-4010-52023	175,000	-	175,000
UCSO Replacement & Renewal			
IFT from General Fund 40080135-4010-52023	175,000	-	175,000
Parks and Rec Replacement & Renewal			
IFT from General Fund 40080134-4010-52023	150,000	(150,000)	-
IFT from General Fund 40080134-4710-52023	-	150,000	150,000
Cane Creek Campground			
IFT from General Fund 40080120-4010-52023	100,000	(100,000)	-
IFT from General Fund 40080120-4710-52023	-	100,000	100,000
SPCC Maintenance			
IFT from General Fund 40080067-4010-52023	100,000	-	100,000
SPCC Technology			
IFT from General Fund 40080076-4010-52023	175,000	-	175,000
SPCC HVAC, Security, Other			
IFT from General Fund 40080077-4010-52023	100,000	-	100,000
Total	2,500,000	-	2,500,000

PROJECT USES

Project Description and Code	Project To Date	Requested Amendment	Revised Project
Facilities Operating Capital			
Building & Improvements 40080131-5580-52023	575,000	-	575,000
Facilities Replacement & Renewal			
Building & Improvements 40080069-5580-52023	950,000	-	950,000
UCSO Operating Capital			
Building & Improvements 40080132-5580-52023	175,000	-	175,000
UCSO Replacement & Renewal			
Building & Improvements 40080135-5580-52023	175,000	-	175,000
Parks and Rec Replacement & Renewal			
Building & Improvements 40080134-5580-52023	150,000	-	150,000
Cane Creek Campground			
Building & Improvements 40080120-5580-52023	100,000	-	100,000
SPCC Maintenance			
Payment to Other Gov't Agencies 40080067-5630-52023	100,000	-	100,000
SPCC Technology			
Payment to Other Gov't Agencies 40080076-5630-52023	175,000	-	175,000
SPCC HVAC, Security, Other			
Payment to Other Gov't Agencies 40080077-5630-52023	100,000	-	100,000
Total	2,500,000	-	2,500,000

Prepared By EC
Posted By _____
Date _____

Number CPO - 305A

UNION COUNTY, NORTH CAROLINA
2025-2026
CAPITAL PROJECT ORDINANCE #343B

NOW, THEREFORE BE IT ORDAINED BY THE BOARD OF COUNTY COMMISSIONERS OF UNION COUNTY, NORTH CAROLINA:

Section I. That for the purpose of providing funds, together with any other previously appropriated available funds, for the following projects:

- SPCC - Campus Improvements Phase I
- SPCC - Building A Restrooms
- SPCC - HVAC Controls - Braswell Building

Including the acquisition and construction of new facilities, the acquisition and installation of necessary furnishings and equipment, and the acquisition of interests in real property as required, this amendment provides for a reallocation of funding within the project by decreasing general obligation bond premium in the amount of \$271,129, decreasing general obligation bond premium investment earnings by \$461,791, and increasing transfers from the General Fund by \$732,920, with no change to the total project cost of \$1,179,273.

Section II. That it is estimated that the following revenues will be available during the construction period to meet the appropriations in Section I, as set forth in the following schedule:

General Obligation Bond Proceeds Premium	\$227,466
Investment Earnings	\$218,887
IFT from General Fund	\$732,920

Section III. The attached CPO #343B chart is incorporated herein showing appropriations to date, additions as of this capital project ordinance, and the total appropriation.

Section IV. That the finance officer is authorized from time to time to transfer as a loan from the General Fund or unspent County proceeds in the Capital Projects Funds, cash in an amount necessary to meet obligations until such time as financing is arranged, at which time repayment will be made and the finance officer is authorized to sign the Declaration of Official Intent to Reimburse Expenditures as required by Internal Revenue Service regulations.

Section V. That the finance officer is authorized at the time of project completion to close out the capital project and remove it from the general ledger.

Section VI. This capital project ordinance is adopted and effective this 4th day of May 2026.

ATTEST:

Lynn G. West, Clerk to the Board

Chair, Union County Board of
Commissioners

CAPITAL PROJECT ORDINANCE AMENDMENT

BUDGET General Capital Fund REQUESTED BY Beverly Liles
 FISCAL YEAR FY 2026 DATE May 4, 2026

PROJECT SOURCES

Source Description and Code	Project To Date	Requested Amendment	Revised Project
General Capital Fund			-
General Obligation Bond Premium	498,595	(271,129)	227,466
General Obligation Bond Investment Earnings	680,678	(461,791)	218,887
IFT from General Fund	-	732,920	732,920
Total	1,179,273	-	1,179,273

PROJECT USES

Project Description and Code	Project To Date	Requested Amendment	Revised Project
General Capital Fund			
SPCC - Campus Improvements Phase I	765,004	-	765,004
SPCC - Building A Restrooms	238,000	-	238,000
SPCC - HVAC Controls - Braswell Building	176,269	-	176,269
Total	1,179,273	-	1,179,273

EXPLANATION: Change funding sources to reduce future arbitrage rebate liabilities.

DATE: 5/4/2026

APPROVED BY: _____
 Bd of Comm/County Manager
 Lynn West/Clerk to the Board

FOR FINANCE POSTING PURPOSES ONLY

PROJECT SOURCES

Source Description and Code	Project To Date	Requested Amendment	Revised Project
SPCC - Campus Improvements Phase I			
GO Bond Proceeds Premium 40080184-4717	271,129	(271,129)	-
SPCC Investment Earnings 40080184-4812	493,875	(461,791)	32,084
IFT from General Fund 40080184-4010	-	732,920	732,920
SPCC - Building A Restrooms			
SPCC GO Bond Proceeds Premium 40080185-4717	100,626	-	100,626
SPCC Investment Earnings 40080185-4812	137,374	-	137,374
SPCC - HVAC Controls - Braswell Building			
GO Bond Proceeds Premium 40080186-4717	126,840	-	126,840
SPCC Investment Earnings 40080186-4812	49,429	-	49,429
Total	1,179,273	-	1,179,273

PROJECT USES

Project Description and Code	Project To Date	Requested Amendment	Revised Project
SPCC - Campus Improvements Phase I			
Payments to Other Govt Units 40080184-5630	765,004	-	765,004
SPCC - Building A Restrooms			
Payments to Other Govt Units 40080185-5630	238,000	-	238,000
SPCC - HVAC Controls - Braswell Building			
Payments to Other Govt Units 40080186-5630	176,269	-	176,269
Total	1,179,273	-	1,179,273

Prepared By EC
 Posted By _____
 Date _____

Number CPO - 343B

UNION COUNTY, NORTH CAROLINA
2025-2026
CAPITAL PROJECT ORDINANCE #347E

NOW, THEREFORE BE IT ORDAINED BY THE BOARD OF COUNTY COMMISSIONERS OF UNION COUNTY, NORTH CAROLINA:

Section I. That for the purpose of providing funds, together with any other available funds, for the following projects:

Annual Operating R&R Projects

- Facilities Operating Capital
- Facilities Replacement & Renewal
- UCSO Operating Capital
- UCSO Replacement & Renewal
- Parks and Rec Replacement & Renewal
- Cane Creek Campground
- SPCC Maintenance
- SPCC Technology
- SPCC HVAC, Security, Other

Including the replacement of equipment, the acquisition and construction of new facilities, the acquisition and installation of necessary furnishings and equipment, and the acquisition of interests in real property as required, this amendment provides for a reallocation of funding within the project by decreasing transfers from the General Fund in the amount of \$153,973 and increasing general obligation bond proceeds by the same amount, with no change to the total project cost of \$3,164,915.

Section II. That it is estimated that the following revenues will be available during the construction period to meet the appropriations in Section I, as set forth in the following schedule:

Interfund Transfer from General Fund	\$ 2,984,182
USDA	\$ 26,760
GO Bond Proceeds	\$ 153,973

Section III. The attached CPO #347E chart is incorporated herein showing appropriations to date, reduction to UCSO Operating Capital as of this capital project ordinance, and the total appropriation.

Section IV. That the finance officer is authorized from time to time to transfer as a loan from the General Fund or unspent County proceeds in the Capital Projects Funds, cash in an amount necessary to meet obligations until such time as financing is arranged, at which time repayment will be made and the finance officer is authorized to sign the Declaration of Official Intent to Reimburse Expenditures as required by Internal Revenue Service regulations.

Section V. That the finance officer is authorized at the time of project completion to close out the capital project and remove it from the general ledger.

Section VI. This capital project ordinance is adopted and effective on this 4th day of May 2026.

ATTEST:

Lynn G. West,
Clerk to the Board

Chair,
Union County Board of Commissioners

CAPITAL PROJECT ORDINANCE AMENDMENT

BUDGET General CIP Fund REQUESTED BY Beverly Liles
 FISCAL YEAR FY 2026 DATE May 4, 2026

PROJECT SOURCES

Source Description and Code	Project To Date	Requested Amendment	Revised Project
IFT from General Fund	3,138,155	(153,973)	2,984,182
USDA Funding	26,760	-	26,760
GO Bond Proceeds	-	153,973	153,973
Total	3,164,915	-	3,164,915

PROJECT USES

Project Description and Code	Project To Date	Requested Amendment	Revised Project
R&R projects for General Capital	2,789,915	-	2,789,915
R&R projects for SPCC	375,000	-	375,000
Total	3,164,915	-	3,164,915

EXPLANATION: Change funding sources to reduce future arbitrage rebate liabilities.

DATE: 5/4/2026

APPROVED BY: _____
 BOCC/County Manager
 Lynn West/Clerk to the Board

FOR FINANCE POSTING PURPOSES ONLY

PROJECT SOURCES

Source Description and Code	Project To Date	Requested Amendment	Revised Project
Facilities Operating Capital			
IFT from General Fund 40080131-4010-52024	575,000	-	575,000
IFT from General Fund 40080131-4860-52024	26,760	-	26,760
Facilities Replacement & Renewal			
IFT from General Fund 40080069-4010-52024	950,000	-	950,000
UCSO Operating Capital			
IFT from General Fund 40080132-4010-52024	20,422	-	20,422
UCSO Replacement & Renewal			
IFT from General Fund 40080135-4010-52024	113,733	-	113,733
UCSO Replacement & Renewal			
IFT from General Fund 40080135-4010-52023	175,000	-	175,000
UCSO Replacement & Renewal			
IFT from General Fund 40080135-4010-52022	100,000	-	100,000
UCSO Replacement & Renewal			
IFT from General Fund 40080135-4010	579,000	-	579,000
Parks and Rec Replacement & Renewal			
IFT from General Fund 40080134-4010-52024	150,000	(150,000)	-
GO Bond Proceeds 40080134-4710-52024	-	150,000	150,000
Cane Creek Campground			
IFT from General Fund 40080120-4010-52024	100,000	(3,973)	96,027
GO Bond Proceeds 40080120-4710-52024	-	3,973	3,973
SPCC Maintenance			
IFT from General Fund 40080067-4010-52024	100,000	-	100,000
SPCC Technology			
IFT from General Fund 40080076-4010-52024	175,000	-	175,000
SPCC HVAC, Security, Other			
IFT from General Fund 40080077-4010-52024	100,000	-	100,000
Total	3,164,915	-	3,164,915

PROJECT USES

Project Description and Code	Project To Date	Requested Amendment	Revised Project
Facilities Operating Capital			
Building & Improvements 40080131-5351-52024	26,760	-	26,760
Building & Improvements 40080131-5580-52024	575,000	-	575,000
Facilities Replacement & Renewal			
Building & Improvements 40080069-5580-52024	950,000	-	950,000
UCSO Operating Capital			
Building & Improvements 40080132-5580-52024	20,422	-	20,422
UCSO Replacement & Renewal			
Building & Improvements 40080135-5580-52024	113,733	-	113,733
UCSO Replacement & Renewal			
Building & Improvements 40080135-5580-52023	175,000	-	175,000
UCSO Replacement & Renewal			
Building & Improvements 40080135-5580-52022	100,000	-	100,000
UCSO Replacement & Renewal			
Building & Improvements 40080135-5580	579,000	-	579,000
Parks and Rec Replacement & Renewal			
Building & Improvements 40080134-5580-52024	150,000	-	150,000
Cane Creek Campground			
Building & Improvements 40080120-5580-52024	100,000	-	100,000
SPCC Maintenance			
Payment to Other Gov't Agencies 40080067-5630-52024	100,000	-	100,000
SPCC Technology			
Payment to Other Gov't Agencies 40080076-5630-52024	175,000	-	175,000
SPCC HVAC, Security, Other			
Payment to Other Gov't Agencies 40080077-5630-52024	100,000	-	100,000
Total	3,164,915	-	3,164,915

Prepared By EC
 Posted By _____
 Date _____

Number CPO - 347E

**UNION COUNTY, NORTH CAROLINA
FISCAL YEAR 2025-2026
CAPITAL PROJECT ORDINANCE #349D**

NOW, THEREFORE BE IT ORDAINED BY THE BOARD OF COUNTY COMMISSIONERS OF UNION COUNTY, NORTH CAROLINA:

Section I. That for the purpose of providing funds, together with any other previously appropriated available funds, for the following projects:

Major Capital:

UC Jail
Judicial Center and Government Center Renovations-Phase 1
UC Jail Rooftop HVAC Systems

Including the replacement of equipment, the acquisition and construction of new facilities, the acquisition and installation of necessary furnishings and equipment, and the acquisition of interests in real property as required, this amendment provides for a reallocation of funding within the project by decreasing transfers from the General Fund in the amount of \$1,378,072 and increasing general obligation bond proceeds by the same amount, with no change to the total project cost of \$19,937,214.

Section II. That it is estimated that the following revenues will be available during the construction period to meet the appropriations in Section I, as set forth in the following schedule:

Interfund Transfer from General Fund	\$3,531,506
Special Revenue Fund	\$1,220,422
2/3 Bond Proceeds	\$14,378,072
GO Bond Proceeds	\$807,214

Section III. The attached CPO #349D chart is incorporated herein showing appropriations to date, additions as of this capital project ordinance, and the total appropriation.

Section IV. That the finance officer is authorized from time to time to transfer as a loan from the General Fund or unspent County proceeds in the Capital Projects Funds, cash in an amount necessary to meet obligations until such time as financing is arranged, at which time repayment will be made and the finance officer is authorized to sign the Declaration of Official Intent to Reimburse Expenditures as required by Internal Revenue Service regulations.

Section V. That the finance officer is authorized at the time of project completion to close out the capital project and remove it from the general ledger.

Section VI. This capital project ordinance is adopted and effective on this 4th day of May 2026.

ATTEST:

Lynn G. West, Clerk to the Board

Chair,
Union County Board of Commissioners

CAPITAL PROJECT ORDINANCE AMENDMENT

BUDGET General CIP Fund

REQUESTED BY Beverly Liles

FISCAL YEAR FY 2026

DATE May 4, 2026

PROJECT SOURCES

Source Description and Code	Project To Date	Requested Amendment	Revised Project
IFT from General Fund	4,909,578	(1,378,072)	3,531,506
IFT from Special Revenue Fund (ARPA Investment Earnings)	1,220,422	-	1,220,422
GO Bond Proceeds	13,000,000	1,378,072	14,378,072
2/3rd Go Bond Premiums	807,214	-	807,214
Total	19,937,214	-	19,937,214

PROJECT USES

Project Description and Code	Project To Date	Requested Amendment	Revised Project
Major Capital Projects	18,337,214	-	18,337,214
Land	1,600,000	-	1,600,000
Total	19,937,214	-	19,937,214

EXPLANATION: Change funding source to reduce future arbitrage rebate liabilities.

DATE: 5/4/2026

APPROVED BY: _____
BOCC/County Manager
Lynn West/Clerk to the Board

FOR FINANCE POSTING PURPOSES ONLY

PROJECT SOURCES

Source Description and Code	Project To Date	Requested Amendment	Revised Project
UC Jail			
IFT From General Fund 40080188-4010	2,379,578	(1,378,072)	1,001,506
IFT From Special Revenue Fund 40080188-4031	1,220,422	-	1,220,422
GO Bond Proceeds 40080188-4710	-	1,378,072	1,378,072
Judicial Center and Government Administration Facilities			
IFT From General Fund 40080190-4010	1,800,000	-	1,800,000
2/3rds GO Bond Premiums 40080190-4717	807,214	-	807,214
GO Bond Proceeds 40080190-4710	13,000,000	-	13,000,000
UC Jail Rooftop HVAC Systems			
IFT From General Fund 40080189-4010	730,000	-	730,000
Total	19,937,214	-	19,937,214

PROJECT USES

Project Description and Code	Project To Date	Requested Amendment	Revised Project
UC Jail			
Building & Improvements 40080188-5580	2,000,000	-	2,000,000
Land and Improvements 40080188-5570	1,600,000	-	1,600,000
Judicial Center and Government Administration Facilities			
Building & Improvements 40080190-5550	15,607,214	-	15,607,214
UC Jail Rooftop HVAC Systems			
Building & Improvements 40080189-5580	730,000	-	730,000
Total	19,937,214	-	19,937,214

Prepared By EC
Posted By _____
Date _____

Number CPO-349D

**UNION COUNTY, NORTH CAROLINA
PUBLIC SAFETY PROJECTS YEAR 2025-2026
CAPITAL PROJECT ORDINANCE #350B**

NOW, THEREFORE BE IT ORDAINED BY THE BOARD OF COUNTY COMMISSIONERS OF UNION COUNTY, NORTH CAROLINA:

Section I. That for the purpose of providing funds, together with any other previously appropriated available funds, for the following projects:

Public Safety:
Radio Replacement and Maintenance
TOMA Radio Infrastructure Upgrade VHF Paging System
Union EMS Capital FY 2024
VFD Air Packs FY 2024

Including the replacement of equipment, the acquisition and construction of new facilities, the acquisition and installation of necessary furnishings and equipment, and the acquisition of interests in real property as required, this amendment provides for a reallocation of funding within the project by decreasing transfers from the General Fund in the amount of \$1,739,095 and increasing general obligation bond proceeds by the same amount, with no change to the total project cost of \$5,999,153.

Section II. That it is estimated that the following revenues will be available during the construction period to meet the appropriations in Section I, as set forth in the following schedule:

IFT from General Fund	\$4,260,058
GO Bond Proceeds	\$1,739,095

Section III. The attached CPO #350B chart is incorporated herein showing appropriations to date, additions as of this capital project ordinance, and the total appropriation.

Section IV. That the finance officer is authorized from time to time to transfer as a loan from the General Fund or unspent County proceeds in the Capital Projects Funds, cash in an amount necessary to meet obligations until such time as financing is arranged, at which time repayment will be made and the finance officer is authorized to sign the Declaration of Official Intent to Reimburse Expenditures as required by Internal Revenue Service regulations.

Section V. That the finance officer is authorized at the time of project completion to close out the capital project and remove it from the general ledger.

Section VI. This capital project ordinance is adopted and effective this 4th day of May 2026.

ATTEST:

Lynn G. West, Clerk to the Board

Chair, Union County Board of
Commissioners

CAPITAL PROJECT ORDINANCE AMENDMENT

BUDGET General CIP Fund

REQUESTED BY Beverly Liles

FISCAL YEAR FY 2026

DATE May 4, 2026

PROJECT SOURCES

Source Description and Code	Project To Date	Requested Amendment	Revised Project
IFT from General Fund	5,999,153	(1,739,095)	4,260,058
GO Bond Proceeds	-	1,739,095	1,739,095
Total	5,999,153	-	5,999,153

PROJECT USES

Project Description and Code	Project To Date	Requested Amendment	Revised Project
Public Safety Capital Projects	5,999,153	-	5,999,153
Total	5,999,153	-	5,999,153

EXPLANATION: Change funding sources to reduce future arbitrage rebate liabilities.

DATE: 5/4/2026

APPROVED BY: _____
BOCC/County Manager
Lynn West/Clerk to the Board

FOR FINANCE POSTING PURPOSES ONLY

PROJECT SOURCES

Source Description and Code	Project To Date	Requested Amendment	Revised Project
Communications- E911			
Radio Replacement and Maintenance			
IFT From General Fund 40080157-4010-52024	300,000	-	300,000
TDMA Radio Infrastructure Upgrade			
IFT From General Fund 40080194-4010	2,372,398	(1,739,095)	633,303
GO Bond Proceeds 40080194-4710	-	1,739,095	1,739,095
VHF Paging System			
IFT From General Fund 40080195-4010	474,755	-	474,755
Union EMS Capital FY 2024			
IFT From General Fund 40080193-4010-52024	2,300,000	-	2,300,000
VFD Air Packs FY 2024			
IFT From General Fund 40080164-4010-52024	552,000	-	552,000
Total	5,999,153	-	5,999,153

PROJECT USES

Project Description and Code	Project To Date	Requested Amendment	Revised Project
Communications- E911			
Radio Replacement and Maintenance			
Other Equipment 40080157-5550-52024	300,000	-	300,000
TDMA Radio Infrastructure Upgrade			
Other Equipment 40080194-5550	2,372,398	-	2,372,398
VHF Paging System			
Other Equipment 40080195-5550	474,755	-	474,755
Union EMS- E911			
Union EMS Capital FY 2024			
Payments to Outside Agencies 40080193-5699-52024	2,300,000	-	2,300,000
VFDs			
VFD Air Packs FY 2024			
Payments to Outside Agencies 40080164-5699-52024	552,000	-	552,000
Total	5,999,153	-	5,999,153

Prepared By EC
Posted By _____
Date _____

Number CPO-350B

**UNION COUNTY, NORTH CAROLINA
FISCAL YEAR 2025-2026
CAPITAL PROJECT ORDINANCE #367D**

NOW, THEREFORE BE IT ORDAINED BY THE BOARD OF COUNTY COMMISSIONERS OF UNION COUNTY, NORTH CAROLINA:

Section I. That for the purpose of providing funds, together with any other available funds, for the following projects:

Annual Operating R&R Projects

- Facilities Operating Capital
- Facilities Replacement & Renewal
- UCSO Operating Capital
- UCSO Replacement & Renewal
- Parks and Rec Replacement & Renewal
- SPCC Maintenance
- SPCC Technology
- SPCC HVAC, Security, Other

Including the replacement of equipment, the acquisition and construction of new facilities, the acquisition and installation of necessary furnishings and equipment, and the acquisition of interests in real property as required, this amendment provides for a reallocation of funding within the project by decreasing transfers from the General Fund in the amount of \$90,869, increasing general obligation bond proceeds by \$15,203, and increasing general obligation bond premium by \$75,666, with no change to the total project cost of \$2,440,900.

Section II. That it is estimated that the following revenues will be available during the construction period to meet the appropriations in Section I, as set forth in the following schedule:

Interfund Transfer from:	
General Fund	\$ 2,350,031
GO Bond Proceeds	\$ 15,203
GO Bond Proceeds Premium	\$ 75,666

Section III. The attached CPO #367D chart is incorporated herein showing appropriations to date, additions as of this capital project ordinance, and the total appropriation.

Section IV. That the finance officer is authorized from time to time to transfer as a loan from the General Fund or unspent County proceeds in the Capital Projects Funds, cash in an amount necessary to meet obligations until such time as financing is arranged, at which time repayment will be made and the finance officer is authorized to sign the Declaration of Official Intent to Reimburse Expenditures as required by Internal Revenue Service regulations.

Section V. That the finance officer is authorized at the time of project completion to close out the capital project and remove it from the general ledger.

Section VI. This capital project ordinance is adopted and effective this 4th day of May 2026.

ATTEST:

Lynn G. West,
Clerk to the Board

Chair
Union County Board of Commissioners

CAPITAL PROJECT ORDINANCE AMENDMENT

BUDGET General CIP Fund
 FISCAL YEAR FY 2026

REQUESTED BY Beverly Liles
 DATE May 4, 2026

PROJECT SOURCES

Source Description and Code	Project To Date	Requested Amendment	Revised Project
IFT from General Fund	2,440,900	(90,869)	2,350,031
GO Bonds Proceeds	-	15,203	15,203
GO Bond Proceeds Premiums	-	75,666	75,666
Total	2,440,900	-	2,440,900

PROJECT USES

Project Description and Code	Project To Date	Requested Amendment	Revised Project
R&R projects for General Capital	2,050,000	-	2,050,000
R&R projects for SPCC	390,900	-	390,900
Total	2,440,900	-	2,440,900

EXPLANATION: Change funding sources to reduce future arbitrage rebate liabilities.

DATE: 5/4/2026

APPROVED BY: _____
 BOCC/County Manager
 Lynn West/Clerk to the Board

FOR FINANCE POSTING PURPOSES ONLY

PROJECT SOURCES

Source Description and Code	Project To Date	Requested Amendment	Revised Project
Facilities Operating Capital			
IFT from General Fund 40080131-4010-52025	630,000	-	630,000
Facilities Replacement & Renewal			
IFT from General Fund 40080069-4010-52025	1,120,000	-	1,120,000
UCSO Operating Capital			
IFT from General Fund 40080132-4010-52025	-	-	-
UCSO Replacement & Renewal			
IFT from General Fund 40080135-4010-52025	-	-	-
Parks and Rec Replacement & Renewal			
IFT from General Fund 40080134-4010-52025	175,000	(90,869)	84,131
GO Bond Proceeds 40080134-4710-52025	-	15,203	15,203
GO Bond Proceeds Premiums 40080134-4717-52025	-	75,666	75,666
CC Campground Replacement & Renewal			
IFT from General Fund 40080120-4010-52025	125,000	-	125,000
SPCC Maintenance			
IFT from General Fund 40080067-4010-52025	115,900	-	115,900
SPCC Technology			
IFT from General Fund 40080076-4010-52025	175,000	(175,000)	-
Investment Earnings 40080076-4812-52025	-	175,000	175,000
SPCC HVAC, Security, Other			
IFT from General Fund 40080077-4010-52025	100,000	-	100,000
Total	2,440,900	-	2,440,900

PROJECT USES

Project Description and Code	Project To Date	Requested Amendment	Revised Project
Facilities Operating Capital			
Building & Improvements 40080131-5580-52025	630,000	-	630,000
Facilities Replacement & Renewal			
Building & Improvements 40080069-5580-52025	1,120,000	-	1,120,000
UCSO Operating Capital			
Building & Improvements 40080132-5580-52025	-	-	-
UCSO Replacement & Renewal			
Building & Improvements 40080135-5580-52025	-	-	-
Parks and Rec Replacement & Renewal			
Building & Improvements 40080134-5580-52025	175,000	-	175,000
CC Campground Replacement & Renewal			
Building & Improvements 40080120-5580-52025	125,000	-	125,000
SPCC Maintenance			
Payment to Other Gov't Agencies 40080067-5630-52025	115,900	-	115,900
SPCC Technology			
Payment to Other Gov't Agencies 40080076-5630-52025	175,000	-	175,000
SPCC HVAC, Security, Other			
Payment to Other Gov't Agencies 40080077-5630-52025	100,000	-	100,000
Total	2,440,900	-	2,440,900

Prepared By EC
 Posted By _____
 Date _____

Number CPO - 367D

**UNION COUNTY, NORTH CAROLINA
FISCAL YEAR 2025-2026
CAPITAL PROJECT ORDINANCE #369B**

NOW, THEREFORE BE IT ORDAINED BY THE BOARD OF COUNTY COMMISSIONERS OF UNION COUNTY, NORTH CAROLINA:

Section I. That for the purpose of providing funds, together with any other previously appropriated available funds, for the following projects:

Major Capital:
UC Parks ADA Improvements
JHP Lighting

Including the replacement of equipment, the acquisition and construction of new facilities, the acquisition and installation of necessary furnishings and equipment, and the acquisition of interests in real property as required, this amendment provides for a reallocation of funding within the project by increasing transfers from the General Fund in the amount of \$393,206, decreasing general obligation bond proceeds by \$317,540, and decreasing general obligation bond premium by \$75,666, with no change to the total project cost of \$750,000.

Section II. That it is estimated that the following revenues will be available during the construction period to meet the appropriations in Section I, as set forth in the following schedule:

Interfund Transfer from General Fund	\$743,206
General Obligation Bond Premiums	\$ 6,794

Section III. The attached CPO #369B chart is incorporated herein showing appropriations to date, additions as of this capital project ordinance, and the total appropriation.

Section IV. That the finance officer is authorized from time to time to transfer as a loan from the General Fund or unspent County proceeds in the Capital Projects Funds, cash in an amount necessary to meet obligations until such time as financing is arranged, at which time repayment will be made and the finance officer is authorized to sign the Declaration of Official Intent to Reimburse Expenditures as required by Internal Revenue Service regulations.

Section V. That the finance officer is authorized at the time of project completion to close out the capital project and remove it from the general ledger.

Section VI. This capital project ordinance is adopted and effective this 4th day of May 2026.

ATTEST:

Lynn G. West, Clerk to the Board

Chair,
Union County Board of Commissioners

CAPITAL PROJECT ORDINANCE AMENDMENT

BUDGET General CIP Fund

REQUESTED BY Beverly Liles

FISCAL YEAR FY 2026

DATE May 4, 2026

PROJECT SOURCES

Source Description and Code	Project To Date	Requested Amendment	Revised Project
IFT from General Fund	350,000	393,206	743,206
General Obligation Bonds	317,540	(317,540)	-
General Obligation Bond Premiums	82,460	(75,666)	6,794
Total	750,000	-	750,000

PROJECT USES

Project Description and Code	Project To Date	Requested Amendment	Revised Project
Major Capital Projects	750,000	-	750,000
Total	750,000	-	750,000

EXPLANATION: Change funding sources to reduce future arbitrage rebate liabilities.

DATE: 5/4/2026

APPROVED BY: _____
BOCC/County Manager
Lynn West/Clerk to the Board

FOR FINANCE POSTING PURPOSES ONLY

PROJECT SOURCES

Source Description and Code	Project To Date	Requested Amendment	Revised Project
UC Parks ADA Improvements			
IFT From General Fund 40080211-4010	350,000	-	350,000
JHP Lighting			
IFT From General Fund 40080212-4010	-	393,206	393,206
General Obligation Bonds (recode from JHP Support Building) 40080212-4710	317,540	(317,540)	-
General Obligation Bond Premiums (recode from JHP Support Building) 40080212-4717	82,460	(75,666)	6,794
Total	750,000	-	750,000

PROJECT USES

Project Description and Code	Project To Date	Requested Amendment	Revised Project
UC Parks ADA Improvements			
Building & Improvements 40080211-5580	350,000	-	350,000
JHP Lighting			
Building & Improvements 40080212-5580	400,000	-	400,000
Total	750,000	-	750,000

Prepared By EC
Posted By _____
Date _____

Number CPO-369B

**UNION COUNTY, NORTH CAROLINA
FISCAL YEAR 2025-2026
CAPITAL PROJECT ORDINANCE #380A**

NOW, THEREFORE BE IT ORDAINED BY THE BOARD OF COUNTY COMMISSIONERS OF UNION COUNTY, NORTH CAROLINA:

Section I. That for the purpose of providing funds, together with any other available funds, for the following projects:

Bookstore/Library Conversion

Including the replacement of equipment, the acquisition and construction of new facilities, the acquisition and installation of necessary furnishings and equipment, and the acquisition of interests in real property as required, this amendment provides for a reallocation of funding within the project by decreasing transfers from the General Fund in the amount of \$303,440, increasing general obligation bond proceeds by \$271,129, and increasing investment earnings by \$32,311, with no change to the total project cost of \$303,440.

Section II. That it is estimated that the following revenues will be available until completion of these projects to meet the appropriations in Section I, as set forth in the following schedule:

GO Bond Proceeds	\$271,129
Investment Earnings	\$ 32,311

Section III. The attached CPO #380A chart is incorporated herein showing appropriations to date, additions as of this capital project ordinance, and the total appropriation.

Section IV. That the finance officer is authorized from time to time to transfer as a loan from the General Fund or unspent County proceeds in the Capital Projects Funds, cash in an amount necessary to meet obligations until such time as financing is arranged, at which time repayment will be made and the finance officer is authorized to sign the Declaration of Official Intent to Reimburse Expenditures as required by Internal Revenue Service regulations.

Section V. That the finance officer is authorized at the time of project completion to close out the capital project and remove it from the general ledger.

Section VI. This capital project ordinance is adopted and effective this 4th day of May 2026.

ATTEST:

Lynn G. West, Clerk to the Board

Chair,
Union County Board of Commissioners

CAPITAL PROJECT ORDINANCE AMENDMENT

BUDGET General Capital Fund

REQUESTED BY Beverly Liles

FISCAL YEAR FY 2026

DATE May 4, 2026

PROJECT SOURCES

Source Description and Code	Project To Date	Requested Amendment	Revised Project
General CIP Fund			
IFT from General Fund	303,440	(303,440)	-
GO Bond Proceeds	-	271,129	271,129
Investment Earnings	-	32,311	32,311
Total	303,440	-	303,440

PROJECT USES

Project Description and Code	Project To Date	Requested Amendment	Revised Project
General CIP Fund			
Bookstore/Library Conversion	303,440.00	-	303,440
			-
			-
Total	303,440	-	303,440

EXPLANATION: Change funding sources to reduce future arbitrage rebate liabilities.

DATE: 5/4/2026

APPROVED BY: _____
Bd of Comm/County Manager
Lynn West/Clerk to the Board

FOR FINANCE POSTING PURPOSES ONLY

PROJECT SOURCES

Source Description and Code	Project To Date	Requested Amendment	Revised Project
General CIP Fund			
Bookstore/Library Conversion			
IFT From General Fund 40080223-4010	303,440	(303,440)	-
GO Bond Proceeds 40080223-4710	-	271,129	271,129
Investment Earnings 40080223-4812	-	32,311	32,311
Total	303,440	-	303,440

PROJECT USES

Project Description and Code	Project To Date	Requested Amendment	Revised Project
General CIP Fund			
Bookstore/Library Conversion			
Payment to Other Gov't Agencies 40080223-5630	303,440	-	303,440
Total	303,440	-	303,440

Prepared By EC
Posted By _____
Date _____

Number CPO - 380A

**UNION COUNTY, NORTH CAROLINA
FISCAL YEAR 2025-2026
CAPITAL PROJECT ORDINANCE #386A**

NOW, THEREFORE BE IT ORDAINED BY THE BOARD OF COUNTY COMMISSIONERS OF UNION COUNTY, NORTH CAROLINA:

Section I. That for the purpose of providing funds, together with any other available funds, for the following projects:

Annual Operating R&R Projects

- Facilities Operating Capital
- Facilities Replacement & Renewal
- UCSO Replacement & Renewal
- Parks and Rec Replacement & Renewal
- SPCC Maintenance
- SPCC Technology
- SPCC HVAC, Security, Other

Including the replacement of equipment, the acquisition and construction of new facilities, the acquisition and installation of necessary furnishings and equipment, and the acquisition of interests in real property as required, this amendment appropriates a reallocation of funding within the project by decreasing transfers from the General Fund in the amount of \$36,444 and increasing investment earnings by the same amount, with no change to the total project cost of \$2,900,900.

Section II. That it is estimated that the following revenues will be available during the construction period to meet the appropriations in Section I, as set forth in the following schedule:

Interfund Transfer from:	
General Fund	\$ 2,864,456
Investment Earnings	\$ 36,444

Section III. The attached CPO #386A chart is incorporated herein showing appropriations to date, additions as of this capital project ordinance, and the total appropriation.

Section IV. That the finance officer is authorized from time to time to transfer as a loan from the General Fund or unspent County proceeds in the Capital Projects Funds, cash in an amount necessary to meet obligations until such time as financing is arranged, at which time repayment will be made and the finance officer is authorized to sign the Declaration of Official Intent to Reimburse Expenditures as required by Internal Revenue Service regulations.

Section V. That the finance officer is authorized at the time of project completion to close out the capital project and remove it from the general ledger.

Section VI. This capital project ordinance is adopted and effective this 4th day of May 2026.

ATTEST:

Lynn G. West, Clerk to the Board

Chair, Union County Board of
Commissioners

CAPITAL PROJECT ORDINANCE AMENDMENT

BUDGET General CIP Fund
 FISCAL YEAR FY 2026

REQUESTED BY Beverly Liles
 DATE May 4, 2026

PROJECT SOURCES

Source Description and Code	Project To Date	Requested Amendment	Revised Project
IFT from General Fund	2,900,900	(36,444)	2,864,456
Investment Earnings		36,444	36,444
			-
Total	2,900,900	-	2,900,900

PROJECT USES

Project Description and Code	Project To Date	Requested Amendment	Revised Project
R&R projects for General Capital	2,525,000	-	2,525,000
R&R projects for SPCC	375,900	-	375,900
			-
Total	2,900,900	-	2,900,900

EXPLANATION: Change funding sources to reduce future arbitrage rebate liabilities.

DATE: _____

APPROVED BY: _____

BOCC/County Manager
 Lynn West/Clerk to the Board

FOR FINANCE POSTING PURPOSES ONLY

PROJECT SOURCES

Source Description and Code	Project To Date	Requested Amendment	Revised Project
Facilities Operating Capital			
IFT from General Fund 40080131-4010-52026	800,000	-	800,000
Facilities Replacement & Renewal			
IFT from General Fund 40080069-4010-52026	1,250,000	-	1,250,000
UCSO Replacement & Renewal			
IFT from General Fund 40080135-4010-52026	100,000	-	100,000
Parks and Rec Replacement & Renewal			
IFT from General Fund 40080134-4010-52026	375,000	-	375,000
SPCC Maintenance			
IFT from General Fund 40080067-4010-52026	115,000	-	115,000
SPCC Technology			
IFT from General Fund 40080076-4010-52026	175,900	(36,444)	139,456
Investment Earnings 40080076-4812-52026	-	36,444	36,444
SPCC HVAC, Security, Other			
IFT from General Fund 40080077-4010-52026	85,000	-	85,000
Total	2,900,900	-	2,900,900

PROJECT USES

Project Description and Code	Project To Date	Requested Amendment	Revised Project
Facilities Operating Capital			
Building & Improvements 40080131-5580-52026	800,000	-	800,000
Facilities Replacement & Renewal			
Building & Improvements 40080069-5580-52026	1,250,000	-	1,250,000
UCSO Replacement & Renewal			
Building & Improvements 40080135-5580-52026	100,000	-	100,000
Parks and Rec Replacement & Renewal			
Building & Improvements 40080134-5580-52026	375,000	-	375,000
SPCC Maintenance			
Payment to Other Gov't Agencies 40080067-5630-52026	115,000	-	115,000
SPCC Technology			
Payment to Other Gov't Agencies 40080076-5630-52026	175,900	-	175,900
SPCC HVAC, Security, Other			
Payment to Other Gov't Agencies 40080077-5630-52026	85,000	-	85,000
Total	2,900,900	-	2,900,900

Prepared By EC
 Posted By _____
 Date _____

Number CPO - 386A

**UNION COUNTY, NORTH CAROLINA
FISCAL YEAR 2025-2026
CAPITAL PROJECT ORDINANCE #388A**

NOW, THEREFORE BE IT ORDAINED BY THE BOARD OF COUNTY COMMISSIONERS OF UNION COUNTY, NORTH CAROLINA:

Section I. That for the purpose of providing funds, together with any other previously appropriated available funds, for the following projects:

Public Safety:
Bi-Directional Antennas at UCPS
Radio Replacements
Union EMS Capital FY 2026
VFD Air Packs FY 2026

Including the replacement of equipment, the acquisition and construction of new facilities, the acquisition and installation of necessary furnishings and equipment, and the acquisition of interests in real property as required, General Obligation bond proceeds are reduced by \$252,000, and transfers from the General Fund is increased accordingly. The total appropriation remains unchanged at \$1,246,918.

Section II. That it is estimated that the following revenues will be available during the construction period to meet the appropriations in Section I, as set forth in the following schedule:

Interfund Transfer from General Fund	\$ 1,198,918
GO Bond Proceeds	\$ 48,000

Section III. The attached CPO #388A chart is incorporated herein showing appropriations to date, additions as of this capital project ordinance, and the total appropriation.

Section IV. That the finance officer is authorized from time to time to transfer as a loan from the General Fund or unspent County proceeds in the Capital Projects Funds, cash in an amount necessary to meet obligations until such time as financing is arranged, at which time repayment will be made and the finance officer is authorized to sign the Declaration of Official Intent to Reimburse Expenditures as required by Internal Revenue Service regulations.

Section V. That the finance officer is authorized at the time of project completion to close out the capital project and remove it from the general ledger.

Section VI. This capital project ordinance is adopted and effective this 4th day of May 2026.

ATTEST:

Lynn G. West,
Clerk to the Board

Chair
Union County Board of Commissioners

CAPITAL PROJECT ORDINANCE AMENDMENT

BUDGET General CIP Fund
 FISCAL YEAR FY 2026

REQUESTED BY Beverly Liles
 DATE May 4, 2026

PROJECT SOURCES

Source Description and Code	Project To Date	Requested Amendment	Revised Project
IFT from General Fund	946,918	252,000	1,198,918
GO Bond Proceeds	300,000	(252,000)	48,000
			-
Total	1,246,918	-	1,246,918

PROJECT USES

Project Description and Code	Project To Date	Requested Amendment	Revised Project
Public Safety Capital Projects	1,246,918	-	1,246,918
			-
Total	1,246,918	-	1,246,918

EXPLANATION: Change funding sources to reduce future arbitrage rebate liabilities.

DATE: 5/4/2026

APPROVED BY: _____

BOCC/County Manager
 Lynn West/Clerk to the Board

FOR FINANCE POSTING PURPOSES ONLY

PROJECT SOURCES

Source Description and Code	Project To Date	Requested Amendment	Revised Project
Bi-Directional Antennas at UCPS			
GO Bond Proceeds 40080224-4717	252,000	(252,000)	-
IFT From General Fund 40080224-4010	-	252,000	252,000
Radio Replacement and Maintenance			
IFT From General Fund 40080157-4010-52026	102,000	-	102,000
GO Bond Proceeds 40080157-4717-52026	48,000	-	48,000
Union EMS Capital FY 2026			
IFT From General Fund 40080193-4010-52026	532,918	-	532,918
VFD Air Packs FY 2026			
IFT From General Fund 40080164-4010-52026	312,000	-	312,000
Total	1,246,918	-	1,246,918

PROJECT USES

Project Description and Code	Project To Date	Requested Amendment	Revised Project
Bi-Directional Antennas at UCPS			
Other Equipment 40080224-5550	252,000	-	252,000
Radio Replacement and Maintenance			
Other Equipment 40080157-5550-52026	150,000	-	150,000
Union EMS Capital FY 2026			
Payments to Outside Agencies 40080193-5699-52026	532,918	-	532,918
VFD Air Packs FY 2026			
Payments to Outside Agencies 40080164-5699-52026	312,000	-	312,000
Total	1,246,918	-	1,246,918

Prepared By EC
 Posted By _____
 Date _____

Number CPO-388A



Union County, NC

Staff Report

Union County Government
Center
500 North Main Street
Monroe, North Carolina
www.unioncountync.gov

File #: 26-224

Agenda Date: 5/4/2026

TITLE:

Juvenile Crime Prevention Council (JCPC) Discretionary Funding Award

INFORMATION CONTACT:

Beverly Liles, Finance, Director, 704-283-3675

ACTION REQUESTED:

1) Approve discretionary awards for FY 2025-2026, 2) authorize the Finance Director to approve an updated funding plan, grant agreements and documents related to these additional funds during their terms, and 3) approve Budget Amendment #22.

PRIOR BOARD ACTIONS:

None.

BACKGROUND:

JCPC is a Board appointed by Commissioners, as defined by State Statutes. JCPC provides funding and monitors Community Based alternatives to juvenile incarceration and provides funding for substance abuse prevention strategies and programs.

Funding for JCPC programs is generally adopted in the State Budget and assigned to County programs by a formula grant.

The JCPC budget is normally approved as a "pass through" line item in the County budget, meaning that the amount approved by the State is received by the County and then used for the JCPC program.

Union County has not approved JCPC programs in line-item detail in the past; rather, the JCPC Board normally negotiates, approves, and monitors line-item detail within the amount of funds allocated to the program, and provides a recommended budget to Commissioners.

JCPC has been awarded discretionary funding for the Transforming Youth program for \$2,450 to use for the remainder of FY 2026.

FINANCIAL IMPACT:

No county funding is required. Any local match will be provided by the Transforming Youth JCPC Program.

BUDGET AMENDMENT

BUDGET Finance REQUESTED BY Beverly Liles

FISCAL YEAR FY 2026 DATE May 04, 2026

INCREASE

Description

JCPC State Grant 2450
 Payment to Outside Agency - Transform Youth 2450

DECREASE

Description

Explanation: To appropriate funds received by the JCPC Discretionary Funds award to Transforming Youth.

DATE _____

APPROVED BY _____
 Bd of Comm/County Manager
 Lynn West/Clerk to the Board

FOR POSTING PURPOSES ONLY

DEBIT

<u>Code</u>	<u>Account</u>	<u>Amount</u>
10114450-5699-17611	Pmt to Outside Agency	2,450
_____	_____	_____
_____	_____	_____
_____	_____	_____
_____	_____	_____

CREDIT

<u>Code</u>	<u>Account</u>	
10114450-4441-17611	JCPC State Grant	2,450
_____	_____	_____
_____	_____	_____
_____	_____	_____
_____	_____	_____

Total 2,450

Total 2,450

Prepared By MEG
 Posted By _____
 Date _____

Number 22



North Carolina Department of Public Safety

Division of Juvenile Justice and Delinquency Prevention Juvenile Community Programs Section

Josh Stein, Governor
J. Jeffrey Smythe, Secretary

William L. Lassiter, Chief Deputy Secretary
Cindy Porterfield, Director

April 8, 2026

Dear Reggie,

Congratulations! The Juvenile Community Programs Section is pleased to announce that **TRANSFORMING YOUTH MOVEMENT / TRANSFORMING FUTURES** has been awarded discretionary funding for FY 2025-2026. This award is to fund (or partially fund) the following:

Agency Request(s)	Awarded Discretionary Funds
<ul style="list-style-type: none"> • Replacement tires for Ford E350 XLT • Maintenance, alternator and windshield replacement 	\$2,450

As a reminder, discretionary awards for FY 2025-2026 are treated as additional JCPC dollars and equipment or capital outlay, valued at \$500 or more with a useful life in excess of one year, must have a cash match. In order to complete the award process, please access NCALLIES, complete a JCPC Program Agreement Revision, and prompt your Area Consultant via email once the revision is completed. If you have any questions or need technical assistance to complete the revision process, please contact your consultant.

We are providing this notification of discretionary fund award to your agency to ensure that all local approval by the JCPC and local county commission boards may be accomplished. Please check with your local county government officials to ensure that all local actions taken to complete this process are in accordance with locally approved/adjusted protocols. Please note the following timeline to ensure timely disbursement of discretionary fund awards:

- **No later than April 24, 2026:** Programs/JCPCs awarded discretionary funds must submit a JCPC Program Agreement Revision in NCALLIES for Area Consultant review (prompt your consultant via email once completed).
- **No later than May 22, 2026:** All JCPC approval actions must be finalized. County approval is required before the disbursement of discretionary funds.

Note: Administrative Code 14B NCAC 11B.0106 states that prior county approval is required for discretionary funds. It does not indicate the specific protocols of the approval.

MAILING ADDRESS:
4212 Mail Service Center
Raleigh, NC 27699-4212

www.ncdps.gov



An Equal Opportunity Employer

OFFICE LOCATION:
3010 Hammond Business Place
Raleigh, NC 27603
Telephone: (919) 733-3388

Our DPS JCPC Policy sets forth local JCPC approval processes. However, the Department is allowing local discretion as to how counties approve requests.

- **May 29, 2026 (by close of business)**: All JCPC Program Agreement Revisions must be locally approved **and signed (not just submitted)** in NCALLIES via DocuSign for a **June 2026** disbursement.

Note: Failure to meet the May 29, 2026 signature deadline may result in termination of the award of discretionary fund

Thank you for your continued investment in the youth and families of North Carolina through the valuable services that you offer for them. It is our hope that this discretionary fund award will further enhance and offer the support needed for your agency to provide continuity of services for our youth and their families.

Kind regards,



Cindy Porterfield, Director
Juvenile Community Programs

cc: JCPC Chairperson
County Finance Officer
DPS Area Consultant



Union County, NC

Staff Report

Union County Government
Center
500 North Main Street
Monroe, North Carolina
www.unioncountync.gov

File #: 26-232

Agenda Date: 5/4/2026

TITLE:

March 2026 NCVTS Motor Vehicle Tax Report

INFORMATION CONTACT:

Vann Harrell, Tax Administration, Tax Administrator, 704-283-3748; Kristen Foxworth, Tax Administration, Deputy Tax Administrator, 704-283-3591

ACTION REQUESTED:

Approve the March 2026 NCVTS Motor Vehicle Tax Refund Report.

PRIOR BOARD ACTIONS:

None.

BACKGROUND:

The refunds included in this report represent adjustments made to tax bills that resulted in refunds of motor vehicle taxes paid under the Tax and Tag Together program operated jointly between the counties and the state.

FINANCIAL IMPACT:

\$895.16



North Carolina Vehicle Tax System

Pending Refund Report

Payee Name	Primary Owner	Secondary Owner	Address 1	Address 2	Address 3	Refund Type	Bill #	Plate Number	Status	Transaction #	Refund Description	Refund Reason	Create Date	Authorization Date	Tax Jurisdiction	Levy Type	Change	Interest Change	Total Change															
CARNEY, THOMAS RICHARD	CARNEY, THOMAS RICHARD		5300 RAVENGLASS CT		MARVIN, NC 28173	Adjustment >=\$100	0089563735	MBL8609	PENDING	1095997266	Refund Generated due to adjustment on Bill #0089563735-2025-2025-0000	Situs error	3/13/2026		001	TAX	\$0.00	\$0.00	\$0.00															
															200	TAX	(\$87.41)	\$0.00	(\$87.41)															
															200	VEHICLE FEE	(\$30.00)	\$0.00	(\$30.00)															
															970	TAX	\$4.47	\$0.00	\$4.47															
															015	TAX	\$9.42	\$0.00	\$9.42															
															003	TAX	\$0.00	\$0.00	\$0.00															
															005	TAX	\$0.00	\$0.00	\$0.00															
															004	TAX	\$0.00	\$0.00	\$0.00															
															002	TAX	\$0.00	\$0.00	\$0.00															
															Refund																		\$103.52	
															POLICKI, APRIL MARIE	POLICKI, APRIL MARIE		4311 ETHEL SUSTAR		MONROE, NC 28110	Adjustment >=\$100	0089508966	MBR4549	PENDING	973960696	Refund Generated due to adjustment on Bill #0089508966-2025-2025-0000	Situs error	3/12/2026		001	TAX	\$0.00	\$0.00	\$0.00
200	TAX	(\$136.85)	\$0.00	(\$136.85)																														
200	VEHICLE FEE	(\$30.00)	\$0.00	(\$30.00)																														
023	TAX	\$13.28	\$0.00	\$13.28																														
003	TAX	\$0.00	\$0.00	\$0.00																														
005	TAX	\$0.00	\$0.00	\$0.00																														
004	TAX	\$0.00	\$0.00	\$0.00																														
002	TAX	\$0.00	\$0.00	\$0.00																														
Refund																														\$153.57				
RILEY, LINDA ELLEN	RILEY, LINDA ELLEN	RILEY, MICHAEL CHARLES	10915 SYCAMORE CLUB DR		MINT HILL, NC 28227	Adjustment >=\$100	0089291725	KFD4513	PENDING	973960872	Refund Generated due to adjustment on Bill #0089291725-2025-2025-0000	Situs error	3/12/2026																	001	TAX	\$0.00	\$0.00	\$0.00
																														200	TAX	(\$133.67)	\$0.00	(\$133.67)
															200	VEHICLE FEE	(\$30.00)	\$0.00	(\$30.00)															
															016	TAX	\$17.16	\$0.00	\$17.16															
															003	TAX	\$0.00	\$0.00	\$0.00															
															005	TAX	\$0.00	\$0.00	\$0.00															
															004	TAX	\$0.00	\$0.00	\$0.00															
															002	TAX	\$0.00	\$0.00	\$0.00															
															Refund																		\$146.51	
															VICTORY GLASS LLC	VICTORY GLASS LLC		2040 INDEPENDENCE COMMERCE	STE B	MATTHEWS, NC 28104	Adjustment >=\$100	0089790130	LHD2439	PENDING	973961256	Refund Generated due to adjustment on Bill #0089790130-2025-2025-0000	Situs error	3/12/2026		001	TAX	\$0.00	\$0.00	\$0.00
																														200	TAX	(\$107.93)	\$0.00	(\$107.93)
200	VEHICLE FEE	(\$30.00)	\$0.00	(\$30.00)																														
020	TAX	\$11.33	\$0.00	\$11.33																														
003	TAX	\$0.00	\$0.00	\$0.00																														
005	TAX	\$0.00	\$0.00	\$0.00																														
004	TAX	\$0.00	\$0.00	\$0.00																														
002	TAX	\$0.00	\$0.00	\$0.00																														
Refund																														\$126.60				
WHITLEY, ETHAN MICHAEL	WHITLEY, ETHAN MICHAEL		7426 NORTH CAROLINA 218 E		MARSHVILLE, NC 28103	Adjustment >=\$100	0089490101	VY4320	PENDING	973960768	Refund Generated due to adjustment on Bill #0089490101-2025-2025-0000	Situs error	3/12/2026																	001	TAX	\$0.00	\$0.00	\$0.00
																														200	TAX	(\$399.74)	\$0.00	(\$399.74)
															200	VEHICLE FEE	(\$30.00)	\$0.00	(\$30.00)															
															017	TAX	\$64.78	\$0.00	\$64.78															
															003	TAX	\$0.00	\$0.00	\$0.00															
															005	TAX	\$0.00	\$0.00	\$0.00															
															004	TAX	\$0.00	\$0.00	\$0.00															
															002	TAX	\$0.00	\$0.00	\$0.00															
															Refund																		\$364.96	
															Refund Total																		\$895.16	



Union County, NC

Staff Report

Union County Government
Center
500 North Main Street
Monroe, North Carolina
www.unioncountync.gov

File #: 26-254

Agenda Date: 5/4/2026

TITLE:

Compensation Adjustment for the Sheriff

INFORMATION CONTACT:

Julie Broome, Human Resources, Director, 704-283-3869

ACTION REQUESTED:

Authorize the County Manager to take such action as necessary to provide an increase in compensation of \$5,375 to the Sheriff, retroactive to January 1, 2026.

BACKGROUND:

Pursuant to G.S.153A-92(a), the Board of Commissioners shall fix or approve the schedule of pay, expense allowance and other compensation of all county officers and employees, whether elected or appointed. Any increase in the compensation of elected officials (Sheriff) is done so at the discretion of the Board of Commissioners.

FINANCIAL IMPACT:

No additional funding required. Sufficient funding is included in the FY26 budget.



Union County, NC

Staff Report

Union County Government
Center
500 North Main Street
Monroe, North Carolina
www.unioncountync.gov

File #: 26-255

Agenda Date: 5/4/2026

TITLE:

Compensation Adjustment for the Register of Deeds

INFORMATION CONTACT:

Julie Broome, Human Resources, Director, 704-283-3869

ACTION REQUESTED:

Authorize the County Manager to take such action as necessary to provide an increase in compensation of \$10,220 to the Register of Deeds, retroactive to January 1, 2026.

BACKGROUND:

Pursuant to G.S.153A-92(a), the Board of Commissioners shall fix or approve the schedule of pay, expense allowance and other compensation of all county officers and employees, whether elected or appointed. Any increase in the compensation of elected officials (Register of Deeds) is done so at the discretion of the Board of Commissioners.

FINANCIAL IMPACT:

No additional funding required. Sufficient funding is included in the FY26 budget.



Union County, NC

Staff Report

Union County Government
Center
500 North Main Street
Monroe, North Carolina
www.unioncountync.gov

File #: 26-250

Agenda Date: 5/4/2026

TITLE:

Resolution - Amend the Board of Commissioners' 2026 Regular Meeting Schedule

INFORMATION CONTACT:

Lynn G. West, Clerk to the Board, 704-283-3853

ACTION REQUESTED:

Adopt the Resolution Amending the Regular Meeting Schedule of the Union County Board of Commissioners for 2026

PRIOR BOARD ACTIONS:

December 8, 2025, Regular Meeting, Agenda Item #25-750 - Adopted the Resolution for the Regular Meeting Schedule of the Union County Board of Commissioners for 2026

BACKGROUND:

On December 8, 2025, the Board of Commissioners adopted its regular meeting schedule for 2026. This resolution amends the previously adopted regular meeting schedule by removing the Monday, June 15, 2026, regular meeting and replacing it with a regular meeting scheduled for the next day, Tuesday, June 16, 2026. The revised regular meeting schedule is shown on Attachment "A" to this Resolution.

FINANCIAL IMPACT:

None.



OFFICE OF THE COMMISSIONERS AND MANAGER

500 N. Main St., Room 921 • Monroe, NC 28112 • Phone (704)283-3810 • Fax (704)282-0121

RESOLUTION AMENDING THE REGULAR MEETING SCHEDULE OF THE UNION COUNTY BOARD OF COMMISSIONERS FOR 2026

THAT WHEREAS, on December 8, 2025, the Union County Board of Commissioners (the “Board”) adopted a resolution entitled “Resolution for the Regular Meeting Schedule of the Union County Board of Commissioners for 2026” (the “Resolution”); which Resolution included adoption of the Board’s regular meeting schedule for 2026; and

WHEREAS, the Board desires to amend its regular meeting schedule for 2026 by deleting the regular meeting of Monday, June 15, 2026, and adding a new regular meeting on Tuesday, June 16, 2026, as shown on Attachment “A” to this Resolution.

NOW, THEREFORE, be it resolved by the Union County Board of Commissioners that it does hereby amend its regular meeting schedule for 2026 by deleting the regular meeting of Monday, June 15, 2026, and adding a regular meeting on a Tuesday, June 16, 2026, as such revised schedule is shown on Attachment “A” to this resolution. Except as herein amended, the Board’s regular meeting schedule for 2026 shall remain in full force and effect.

Adopted this the 4th day of May, 2026.

ATTEST:

Lynn G. West, Clerk to the Board

Brian Helms, Chair



Attachment A (Revised May 4, 2026)

**2026 REGULAR MEETING SCHEDULE
UNION COUNTY BOARD OF COMMISSIONERS
500 North Main Street
Monroe, NC 28112**

MEETING DATE	MEETING TIME
Monday, January 12, 2026 (2nd Monday)	5:15 p.m.
Monday, February 2, 2026	5:15 p.m.
Tuesday, February 17, 2026 (Tuesday meeting)	5:15 p.m.
Monday, March 2, 2026	5:15 p.m.
Monday, March 16, 2026	5:15 p.m.
Monday, April 20, 2026	5:15 p.m.
Monday, May 4, 2026	5:15 p.m.
Monday, May 18, 2026	5:15 p.m.
Monday, June 1, 2026	5:15 p.m.
Tuesday, June 16, 2026 (Tuesday meeting)	5:15 p.m.
Monday, July 20, 2026	5:15 p.m.
Monday, August 17, 2026	5:15 p.m.
Monday, September 21, 2026	5:15 p.m.
Monday, October 5, 2026	5:15 p.m.
Monday, October 19, 2026	5:15 p.m.
Monday, November 2, 2026	5:15 p.m.
Monday, November 16, 2026	5:15 p.m.
Monday, December 7, 2026	5:15 p.m.
Monday, December 21, 2026 (Subject to cancellation due to the holidays)	5:15 p.m.

Regular Meetings are generally held on the 1st and 3rd Monday of the month in the Meeting Chamber on the 1st floor of the Union County Government Center located at 500 North Main Street, Monroe N.C. When a regular meeting would fall on a holiday, the meeting is often held on Tuesday. Above is the official Regular Meeting schedule, with the specific dates and times for each meeting.

*NOTE: The official start time for most Regular Meetings is 5:15 p.m. Unless otherwise indicated on each meeting’s official agenda, the public portion of the meeting is generally held as close to 6:00 p.m. as possible, following Closed Session at 5:15 p.m. Closed Sessions are held in the Commissioner Stony D. Rushing Conference Meeting Room on the 1st floor. As indicated on each meeting’s official agenda, the Board may choose to hold public work sessions from 5:15-6:00 p.m. for certain Regular Meetings.



Union County, NC

Staff Report

Union County Government
Center
500 North Main Street
Monroe, North Carolina
www.unioncountync.gov

File #: 26-263

Agenda Date: 5/4/2026

TITLE:

Resolution - Opioid Settlement Funding Plan (FY2027-FY2030)

INFORMATION CONTACT:

Patrick Niland, County Manager's Office, Deputy County Manager, 704-283-3630

ACTION REQUESTED:

1) Adopt the Resolution to Direct the Expenditure of Opioid Settlement Funds for FY2027-FY2030; and 2) authorize the County Manager to negotiate and execute agreements and related documents consistent with this agenda item.

PRIOR BOARD ACTIONS:

June 19, 2023, Regular Meeting, Agenda Item # 23-367 - Board approval of the first phase of opioid settlement funding.

BACKGROUND:

North Carolina participated in the national opioid settlements, and the North Carolina Association of County Commissioners (NCACC) and the North Carolina Department of Justice (NCDOJ) partnered to help ensure settlement proceeds are distributed to local jurisdictions for programs and services that directly benefit individuals and communities most impacted by the opioid epidemic.

Union County entered into Memorandums of Agreement (MOAs) with the State of North Carolina governing both the amount of settlement funding to be received and the allowable uses of those funds. These agreements also establish the framework for how North Carolina and participating local governments will use proceeds from future national settlements or bankruptcy resolutions involving opioid manufacturers, distributors, and related entities.

Union County is projected to receive approximately \$19.9 million in opioid settlement proceeds over an 18-year period. Under the terms of the MOAs, local governments are required to engage in a collaborative planning process to determine how these funds will be invested.

To meet this requirement, County staff convened community stakeholders beginning in September 2025 and facilitated a four-month strategic planning process to develop recommendations for the FY2027-FY2030 funding period. Those recommendations were presented to and endorsed by the Board of Commissioners at its April 20, 2026, Regular Meeting.

The attached resolution directs the expenditure of opioid settlement funds in accordance with that approved funding plan and authorizes the County Manager to implement the plan through agreements with selected providers and partners.

FINANCIAL IMPACT:

\$7,020,950.39 in opioid settlement funds is proposed for allocation under the FY2027-FY2030 funding plan.



OFFICE OF THE COMMISSIONERS AND MANAGER

500 N. Main St., Room 921 • Monroe, NC 28112 • Phone (704)283-3810 • Fax (704)282-0121

A RESOLUTION BY THE COUNTY OF UNION TO DIRECT THE EXPENDITURE OF OPIOID SETTLEMENT FUNDS

WHEREAS Union County has joined national settlement agreements with companies engaged in the manufacturing, distribution, and dispensing of opioids.

WHEREAS the allocation, use, and reporting of funds stemming from these national settlement agreements and bankruptcy resolutions (“Opioid Settlement Funds”) are governed by the Memorandum of Agreement Between the State of North Carolina and Local Governments on Proceeds Relating to the Settlement of Opioid Litigation (“MOA”), the Supplemental Agreement for Additional Funds from Additional Settlements of Opioid Litigation (“SAAF”), SAAF-2 and SAAF-3;

WHEREAS Union County has received Opioid Settlement Funds pursuant to these national settlement agreements and deposited the Opioid Settlement Funds in a separate special revenue fund as required by section D of the MOA;

WHEREAS section E.6 of the MOA states that, before spending opioid settlement funds, the local government’s governing body must adopt a resolution that:

- (i) indicates that it is an authorization for expenditure of opioid settlement funds; and,
- (ii) states the specific strategy or strategies the county or municipality intends to fund pursuant to Option A or Option B, using the item letter and/or number in Exhibit A or Exhibit B to identify each funded strategy; and,
- (iii) states the amount dedicated to each strategy for a specific period of time.

NOW, THEREFORE BE IT RESOLVED, in alignment with the NC MOA, SAAF, SAAF-2, and SAAF-3 Union County authorizes the expenditure of opioid settlement funds as follows:

1. First strategy authorized
 - a. Name of strategy: **Recovery Support Services (A.3)**: Fund evidence-based recovery support services, including peer support specialists or care

navigators based in local health departments, social service offices, detention facilities, community-based organizations, or other settings that support people in treatment or recovery, or people who use drugs, in accessing addiction treatment, recovery support, harm reduction services, primary healthcare, or other services or supports they need to improve their health or well-being.

- b.** Strategy is included in Exhibit: A
- c.** Item letter and/or number in Exhibit A or Exhibit B to the MOA: Exhibit A.3
- d.** Amount authorized for this strategy: \$ **610,264.00**
- e.** Period of time during which expenditure may take place:
Start date July 1, 2026, through End date June 30, 2030
- f.** Description of the program, project, or activity: Peer Support Services: Two Peer Support Specialists will support Treatment Courts, and Hajee House will partner with the Union County Human Services Recovery Support Program. Hajee peer support staff will provide direct, community-based support.
- g.** Providers: **District Court-Chief District Court Judge Erin Hucks, and Hajee House**

2. Second strategy authorized

- a.** Name of strategy: **Evidence-Based Addiction Treatment (A.2):** Support evidence-based addiction treatment consistent with the American Society of Addiction Medicine’s national practice guidelines for the treatment of opioid use disorder – including Medication-Assisted Treatment (MAT) with any medication approved for this purpose by the U.S. Food and Drug Administration – through Opioid Treatment Programs, qualified providers of Office-Based Opioid Treatment, Federally Qualified Health Centers, treatment offered in conjunction with justice system programs, or other community-based programs offering evidence based addiction treatment. This may include capital expenditures for facilities that offer evidence-based treatment for OUD.
- b.** Strategy is included in Exhibit A
- c.** Item letter and/or number in Exhibit A or Exhibit B to the MOA: Exhibit A.2
- d.** Amount authorized for this strategy: \$ **700,000.00**
- e.** Period of time during which expenditure may take place:
Start date: July 1, 2026, through End date June 30, 2030
- f.** Description of the program, project, or activity: Evidence-Based Addiction Treatment will expand access to proven treatment for Union County residents with opioid use disorder, including medication-assisted treatment, integrated

behavioral health care, and coordinated referral pathways. The program will support timely connection to care through qualified providers

- g. Provider: **New Beginnings of the Southern Piedmont LLC, and McLeod Center for Wellbeing****

3. Third authorized strategy

- a. Name of strategy: **Early Intervention (A.6):**** Fund programs, services, or training to encourage early identification and intervention for children or adolescents who may be struggling with problematic use of drugs or mental health conditions, including Youth Mental Health First Aid, peer-based programs, or similar approaches. Training programs may target parents, family members, caregivers, teachers, school staff, peers, neighbors, health or human services professionals, or others in contact with children or adolescents.
- b. Strategy is included in Exhibit A**
- c. Item letter and/or number in Exhibit A or Exhibit B to the MOA: Exhibit A.6**
- d. Amount authorized for this strategy: **\$1,450,175.00****
- e. Period of time during which expenditure may take place:**
Start date: July 1, 2026, through End date June 30, 2030
- f. Description of the program, project, or activity:** Cameron’s House of Hope and the Human Services Agency’s Behavioral Health Collaborative will support Strategy A.6 by providing early intervention and family-centered services for children, adolescents, and caregivers affected by substance use and behavioral health challenges. The Behavioral Health Collaborative will strengthen prevention, screening, referral, counseling services, while Cameron’s House of Hope will provide tutoring, counseling, mentoring, and family support services to improve access to care and promote long-term stability and recovery for Union County families.
- g. Provider: **Cameron’s House of Hope and Human Services Agency, Behavioral Health Collaborative.****

4. Fourth authorized strategy

- a. Name of strategy: **Prevent Misuses of Opioids (B-G.8):**** Fund evidence-based prevention programs in schools or evidence informed school and community education programs and campaigns for students, families, school employees, school athletic programs, parent-teacher and student associations, and others.
- b. Strategy is included in Exhibit B**
- c. Item letter and/or number in Exhibit A or Exhibit B to the MOA: Exhibit B-G.8**

- d. Amount authorized for this strategy: **\$1,293,038.00**
- e. Period of time during which expenditure may take place:
Start date: July 1, 2026, through End date June 30, 2030
- f. Description of the program, project, or activity: Union County Public Schools will strengthen early prevention and youth programs by expanding a comprehensive K–12 substance use prevention continuum. This expansion will be accomplished through three staff positions: one Lead Substance Abuse Prevention Coordinator and two Substance Abuse Educators. In Year 1, services will be provided at Sun Valley Middle School, Sun Valley High School, Porter Ridge Middle and High, Monroe High School, and the Health Science Academy at Monroe Middle School; in Years 2–4, services will continue at those schools and expand to Shiloh Valley Elementary, Porter Ridge Elementary, and East Elementary. The program will provide age-appropriate instruction on decision-making, goal setting, peer resistance, media literacy, and risk awareness, along with staff development, parent education, early intervention support for at-risk students, and train-the-trainer models to build sustainable school capacity and support long-term student success.
- g. Provider: **Union County Public Schools**

5. Fifth strategy authorized

- a. Name of strategy: **Support People in Treatment and Recovery (B-B.3):**
Provide counseling, peer-support, recovery case management and residential treatment with access to medications for those who need it to persons with OUD and any co-occurring SUD/MH conditions.
- b. Strategy is included in Exhibit B
- c. Item letter and/or number in Exhibit A or Exhibit B to the MOA: Exhibit B-B.3
- d. Amount authorized for this strategy: **\$300,000.00**
- e. Period of time during which expenditure may take place:
Start date: July 1, 2026, through End date June 30, 2030
- f. Description of the program, project, or activity: 30-day drug and alcohol treatment program specializing in evidence-based, counseling-based and abstinence-base treatment for Opioid-Use Disorder patients. Service is provided to Union County residents who typically cannot access state-sponsored care (Medicaid managed care through Partners LME/MCO).
- g. Provider: **Bridge to Recovery Regional Recovery Center**

6. Sixth authorized strategy

- a. Name of strategy: **Address the needs of Criminal-Justice Involved Person (B-D.3)**: Support treatment and recovery courts that provide evidence-based options for persons with OUD and any co-occurring SUD/MH conditions.
- b. Strategy is included in Exhibit B
- c. Item letter and/or number in Exhibit A or Exhibit B to the MOA: Exhibit B-D.3
- d. Amount authorized for this strategy: **\$1,927,626.00**
- e. Period of time during which expenditure may take place:
Start date: July 1, 2026, through End date June 30, 2030
- f. Description of the program, project, or activity: Family Treatment Court and Veterans Treatment Court will support Strategy B-D.3 by addressing the needs of criminal-justice-involved individuals with opioid use disorder and co-occurring substance use or mental health conditions through structured, evidence-based treatment and recovery pathways. These courts provide coordinated oversight, trauma-informed support, peer engagement, and access to treatment, mental health services, and other supportive resources to improve recovery outcomes, reduce recidivism, and promote long-term stability for participants and their families.
- g. Provider: **District Court-Chief District Court Judge Erin Hucks**

7. Seventh strategy authorized

- a. Name of strategy: **Collaborative Strategic Planning (A.1)**: Support collaborative strategic planning to address opioid misuse, addiction, overdose, or related issues, including staff support, facilitation services, or any activity or combination of activities listed in Exhibit C to the MOA (collaborative strategic planning).
- b. Strategy is included in Exhibit A
- c. Item letter and/or number in Exhibit A or Exhibit B to the MOA: Exhibit A.1
- d. Amount authorized for this strategy: **\$300,000.00**
- e. Period of time during which expenditure may take place:
Start date: July 1, 2026, through End date June 30, 2030
- f. Description of the program, project, or activity: Collaborative Strategic Planning, will support the administrative infrastructure needed to manage Union County's opioid settlement investments with accountability and compliance. Administrative costs will include 50% of the salary for the Opioid Settlement Program Manager, annual single-audit expenses, software and data-tracking costs, and other operational expenses necessary to support program oversight, reporting, coordination, and fiscal stewardship.

g. Provider: Union County Manager's Office

8. Eight strategy authorized

- a. Name of strategy: Naloxone Distribution (A.7):** Support programs or organizations that distribute naloxone to persons at risk of overdose or their social networks, such as SSP Programs, post-overdose response teams, programs that provide naloxone to persons upon release from jail or prison, emergency medical service providers or hospital emergency departments that provide naloxone to persons at risk of overdose, or community-based organizations that provide services to people who use drugs. Programs or organizations involved in community distribution of naloxone may, in addition, provide naloxone to first responders.
- b. Strategy is included in Exhibit A**
- c. Item letter and/or number in Exhibit A or Exhibit B to the MOA: Exhibit A.7**
- d. Amount authorized for this strategy: \$140,000.00**
- e. Period of time during which expenditure may take place:**
Start date: July 1, 2026, through End date June 30, 2030
- f. Description of the program, project, or activity:** Naloxone Distribution will support the purchase of naloxone for use by first responders and for broader community distribution to help reduce overdose deaths and improve access to lifesaving resources. This investment will strengthen Union County's ability to respond promptly to opioid-related emergencies and expand availability for residents, families, and community partners. The Union County Recovery Support Services Program staff will work collaboratively with the Health Department Pharmacist to oversee and manage the naloxone distribution
- g. Provider: Union County Human Services Agency**

9. Ninth strategy authorized

- a. Name of strategy: Employee-Related Services (A.5):** Fund programs offering employment support services to people in treatment or recovery, or people who use drugs, such as job training, job skills, job placement, interview coaching, resume review, professional attire, relevant courses at community colleges or vocational schools, transportation services or transportation vouchers to facilitate any of these activities, or similar services or supports.
- b. Strategy is included in Exhibit A**
- c. Item letter and/or number in Exhibit A or Exhibit B to the MOA: Exhibit A.5**

- d. Amount authorized for this strategy: \$200,000.
- e. Period of time during which expenditure may take place:
Start date: July 1, 2026, through End date June 30, 2030
- f. Description of the program, project, or activity: Employment-Related Services, will support people in treatment or recovery by connecting them to employment supports and transportation needed to improve stability and long-term recovery. The Human Services Recovery Support Services Program team will help manage this effort by working with funded agencies and peer support staff to navigate individuals to available resources, including job training, job readiness services, resume assistance, interview preparation, and workforce partners such as Economic Development, the Chamber of Commerce, NC Works, SPCC, staffing agencies, and other community providers. This initiative will also fund transportation vouchers or services to help individuals with substance use disorder access MAT treatment, court-related drug testing appointments, treatment court appointments, job training, and other recovery-related services. This approach will reduce barriers to care and employment, support direct linkage from post-overdose response into treatment, and promote recovery-friendly pathways to long-term success.
- g. Provider: **Union County Human Services Agency**

10. Tenth strategy authorized

- a. Name of strategy: **Prevent Misuse of Opioids (B-G.1)**, Fund media campaigns to prevent opioid misuse
- b. Strategy is included in Exhibit B
- c. Item letter and/or number in Exhibit A or Exhibit B to the MOA: Exhibit B-G.1
- d. Amount authorized for this strategy: \$100,000.00
- e. Period of time during which expenditure may take place:
Start date: July 1, 2026, through End date June 30, 2030
- f. Description of the program, project, or activity: Prevent Misuse of Opioids, will support a public education and awareness initiative that provides clear, reliable information to residents and families about opioid risks, prevention, and the services available in Union County. The campaign will use community-centered messaging and carefully selected personal stories of hope, resilience, and recovery to encourage understanding, reduce barriers to seeking help, and highlight that support is available. It will also improve awareness of where and how to access treatment, recovery support, and

other local resources so individuals and families can connect to care as early as possible.

- g. Provider: Union County Public Communications**

The total dollar amount of Opioid Settlement Funds appropriated across the above named and authorized strategies is **\$7,020,950.38**

Adopted this the 4 day of May 2026.

Brian Helms, Chair
Union County Board of Commissioners

ATTEST:

Lynn West, Clerk to the Board

COUNTY SEAL



Union County, NC

Staff Report

Union County Government
Center
500 North Main Street
Monroe, North Carolina
www.unioncountync.gov

File #: 26-211

Agenda Date: 5/4/2026

TITLE:

Tax Collector's Departmental Report for March 2026

INFORMATION CONTACT:

Kristen Foxworth, Tax Administration, Deputy Tax Administrator, 704-283-3591

ACTION REQUESTED:

None - Information Only.

PRIOR BOARD ACTIONS:

None.

BACKGROUND:

This report reflects the totals of all tax transactions within the Tax Collector's Office for the month of March 2026 as required by NCGS 105-350(7).

FINANCIAL IMPACT:

None.

Memorandum

To: Board of County Commissioners
Brian Matthews, County Manager
Lynn West, Clerk to the Board

From: Vann Harrell
Tax Administrator

Date: April 10, 2026

Re: Departmental Monthly Report

The Tax Collector's monthly/year to date collections report for the month ending March 31, 2026 is attached for your information and review.

Should you desire additional information, I will provide that at your request.

Attachment

VH/JM

**MARCH 2026
PERCENTAGE FOR REGULAR TAX**

MARCH 31, 2026 REGULAR TAX	2026	2025	2024	2023	2022
BEGINNING CHARGE	468,520.37	274,845,912.58	237,279,756.79	226,212,439.28	217,099,719.80
TAX CHARGE					
PUBLIC UTILITIES CHARGE					
DISCOVERIES	74,919.03	227.97			
NON DISCOVERIES		4,863.50	6,204.82	6,091.35	496.22
RELEASES	(7,083.98)	(6,597.93)	(765.84)		
TOTAL CHARGE	536,355.42	274,844,406.12	237,285,195.77	226,218,530.63	217,100,216.02
BEGINNING COLLECTIONS	88,738.58	271,299,952.66	237,124,184.92	226,126,583.29	217,042,380.50
COLLECTIONS	32,665.83	2,052,445.18	11,071.48	10,764.32	4,823.93
TOTAL COLLECTIONS	121,404.41	273,352,397.84	237,135,256.40	226,137,347.61	217,047,204.43
BALANCE OUTSTANDING	414,951.01	1,492,008.28	149,939.37	81,183.02	53,011.59
PERCENTAGE OF REGULAR	22.64%	99.46%	99.94%	99.96%	99.98%
OVERALL CHARGED	536,355.42	274,844,406.12	237,285,195.77	226,218,530.63	217,100,216.02
OVERALL COLLECTED	121,404.41	273,352,397.84	237,135,256.40	226,137,347.61	217,047,204.43
OVERALL PERCENTAGE	22.64%	99.46%	99.94%	99.96%	99.98%

**MARCH 2026
PERCENTAGE FOR REGULAR TAX**

MARCH 31, 2026 REGULAR TAX	2021	2020	2019	2018
BEGINNING CHARGE	208,193,368.98	192,181,155.30	186,540,147.30	180,717,811.44
TAX CHARGE				
PUBLIC UTILITIES CHARGE				
DISCOVERIES				
NON DISCOVERIES				
RELEASES				
TOTAL CHARGE	208,193,368.98	192,181,155.30	186,540,147.30	180,717,811.44
BEGINNING COLLECTIONS	208,144,189.35	192,113,093.66	186,444,538.85	180,661,472.18
COLLECTIONS	42.25	44.21	202.73	142.28
TOTAL COLLECTIONS	208,144,231.60	192,113,137.87	186,444,741.58	180,661,614.46
BALANCE OUTSTANDING	49,137.38	68,017.43	95,405.72	56,196.98
PERCENTAGE OF REGULAR	99.98%	99.96%	99.95%	99.97%
OVERALL CHARGED	208,193,368.98	192,181,155.30	186,540,147.30	180,717,811.44
OVERALL COLLECTED	208,144,231.60	192,113,137.87	186,444,741.58	180,661,614.46
OVERALL PERCENTAGE	99.98%	99.96%	99.95%	99.97%

**MARCH 2026
PERCENTAGE FOR REGULAR TAX**

MARCH 31, 2026 REGULAR TAX	2017	2016
BEGINNING CHARGE	186,663,147.61	176,859,604.37
TAX CHARGE		
PUBLIC UTILITIES CHARGE		
DISCOVERIES		
NON DISCOVERIES		
RELEASES		
TOTAL CHARGE	186,663,147.61	176,859,604.37
BEGINNING COLLECTIONS	186,616,982.76	176,821,901.19
COLLECTIONS	157.28	167.74
TOTAL COLLECTIONS	186,617,140.04	176,822,068.93
BALANCE OUTSTANDING	46,007.57	37,535.44
PERCENTAGE OF REGULAR	99.98%	99.98%
OVERALL CHARGED	186,663,147.61	176,859,604.37
OVERALL COLLECTED	186,617,140.04	176,822,068.93
OVERALL PERCENTAGE	99.98%	99.98%



Union County, NC

Staff Report

Union County Government
Center
500 North Main Street
Monroe, North Carolina
www.unioncountync.gov

File #: 26-231

Agenda Date: 5/4/2026

TITLE:

Tax Refunds, Releases and Prorations Approved by Finance Officer

INFORMATION CONTACT:

Beverly Liles, Finance, Director, 704-283-3675

ACTION REQUESTED:

None - Information Only.

PRIOR BOARD ACTIONS:

None.

BACKGROUND:

On September 8, 2020, the Board of Commissioners adopted a Resolution Delegating Authority for Tax Releases and Refunds of less than \$100 to Union County's Finance Officer. The resolution and NC GS 105-381(b) require such refunds to be reported to the Board regarding actions taken on requests for releases or refunds. All such actions shall be recorded in the Board's minutes. NC GS 105-330.6 authorizes the tax collector to direct an order for a tax refund of prorated taxes to the county finance officer related to surrendering of registered motor vehicle plates. The finance officer shall issue a refund to the vehicle owner. The attached report is for March 2026 NCVTS releases and refunds less than \$100 and prorations approved by the finance officer.

FINANCIAL IMPACT:

None.



North Carolina Vehicle Tax System

Pending Refund Report

Payee Name	Primary Owner	Secondary Owner	Address 1	Address 2	Address 3	Refund Type	Bill #	Plate Number	Status	Transaction #	Refund Description	Refund Reason	Create Date	Authorization Date	Tax Jurisdiction	Levy Type	Change	Interest Change	Total Change
BHARTI, SHIVANAND	BHARTI, SHIVANAND		595 PALMERSTON LN	WAXHAN, NC 28173	Proration	0081064646	YNH6674	AUTHORIZED	731396304	Refund Generated due to proration on Bill #0081064646-2024-2024-0000-00	Vehicle Sold	3/18/2026	3/19/2026	001	TAX	(\$4.98)	\$0.00	(\$4.98)	
														026	TAX	(\$1.22)	\$0.00	(\$1.22)	
														003	TAX	(\$0.53)	\$0.00	(\$0.53)	
														005	TAX	(\$0.12)	\$0.00	(\$0.12)	
														004	TAX	(\$0.89)	\$0.00	(\$0.89)	
														002	TAX	(\$11.42)	\$0.00	(\$11.42)	
Refund																	\$19.16		
BITZ, MEGHAN GRACE	BITZ, MEGHAN GRACE		8 ISLAND RD	PHOENIX, NY 13135	Proration	0076329374	KHX7727	AUTHORIZED	850638719	Refund Generated due to proration on Bill #0076329374-2024-2024-0000-00	Reg. Out of state	3/4/2026	3/5/2026	001	TAX	(\$4.29)	\$0.00	(\$4.29)	
														600	TAX	(\$4.86)	\$0.00	(\$4.86)	
														019	TAX	(\$1.68)	\$0.00	(\$1.68)	
														003	TAX	(\$0.46)	\$0.00	(\$0.46)	
														005	TAX	(\$0.10)	\$0.00	(\$0.10)	
														004	TAX	(\$0.77)	\$0.00	(\$0.77)	
002	TAX	(\$9.84)	\$0.00	(\$9.84)															
Refund																	\$22.00		
BLACK, MYLES DONALD	BLACK, MYLES DONALD		5011 MYERS RD	MONROE, NC 28110	Proration	0083744061	9K4787	AUTHORIZED	851689636	Refund Generated due to proration on Bill #0083744061-2024-2024-0000-00	Vehicle Sold	3/9/2026	3/10/2026	001	TAX	(\$0.45)	\$0.00	(\$0.45)	
														200	TAX	(\$1.38)	\$0.00	(\$1.38)	
														200	VEHICLE FEE	\$0.00	\$0.00	\$0.00	
														003	TAX	(\$0.05)	\$0.00	(\$0.05)	
														005	TAX	(\$0.01)	\$0.00	(\$0.01)	
														004	TAX	(\$0.08)	\$0.00	(\$0.08)	
002	TAX	(\$1.03)	\$0.00	(\$1.03)															
Refund																	\$3.00		
BLYTHE, ELIZABETH DANIELLE	BLYTHE, ELIZABETH DANIELLE		124 HOUSTON BLAIR RD	MATTHEWS, NC 28104	Adjustment < \$100	0089923267	JEC4053	PENDING	976464896	Refund Generated due to adjustment on Bill #0089923267-2025-2025-0000	Situs error	3/23/2026		001	TAX	\$0.00	\$0.00	\$0.00	
														700	TAX	(\$43.41)	\$0.00	(\$43.41)	
														700	VEHICLE FEE	(\$25.00)	\$0.00	(\$25.00)	
														020	TAX	\$0.00	\$0.00	\$0.00	
														003	TAX	\$0.00	\$0.00	\$0.00	
														005	TAX	\$0.00	\$0.00	\$0.00	
004	TAX	\$0.00	\$0.00	\$0.00															
002	TAX	\$0.00	\$0.00	\$0.00															
Refund																	\$68.41		
BRCL0 CAPITAL LLC	BRCL0 CAPITAL LLC		1208 FIRETHORNE CLUB DR	WAXHAN, NC 28173	Proration	0085434294	VS2559	AUTHORIZED	977188872	Refund Generated due to proration on Bill #0085434294-2024-2024-0000-00	Vehicle Sold	3/26/2026	3/27/2026	001	TAX	(\$16.85)	\$0.00	(\$16.85)	
														101	TAX	(\$8.26)	\$0.00	(\$8.26)	
														101	VEHICLE FEE	\$0.00	\$0.00	\$0.00	
														026	TAX	(\$4.11)	\$0.00	(\$4.11)	
														003	TAX	(\$1.81)	\$0.00	(\$1.81)	
														005	TAX	(\$0.40)	\$0.00	(\$0.40)	
004	TAX	(\$3.01)	\$0.00	(\$3.01)															
002	TAX	(\$38.63)	\$0.00	(\$38.63)															
Refund																	\$73.07		
BRENIZE, MATTHEW SCOTT	BRENIZE, MATTHEW SCOTT	BRENIZE, TINA CANADAY	2209 POPLAR RIDGE DR	MONROE, NC 28110	Proration	0089572532	WAT3870	AUTHORIZED	730865664	Refund Generated due to proration on Bill #0089572532-2025-2025-0000-00	Vehicle Sold	3/16/2026	3/17/2026	001	TAX	(\$15.06)	\$0.00	(\$15.06)	
														026	TAX	(\$4.07)	\$0.00	(\$4.07)	
														003	TAX	(\$1.42)	\$0.00	(\$1.42)	
														005	TAX	(\$0.60)	\$0.00	(\$0.60)	
														004	TAX	(\$5.22)	\$0.00	(\$5.22)	
														002	TAX	(\$35.89)	\$0.00	(\$35.89)	
Refund																	\$62.26		
BROCKMANN, WILLIAM PAUL	BROCKMANN, WILLIAM PAUL		1110 REAL QUIET LN	WAXHAN, NC 28173	Proration	0072796857	KBJ9623	AUTHORIZED	733788588	Refund Generated due to proration on Bill #0072796857-2024-2024-0000-00	Vehicle Sold	3/30/2026	3/31/2026	001	TAX	(\$51.79)	(\$2.59)	(\$54.38)	
														026	TAX	(\$12.63)	(\$0.63)	(\$13.26)	
														003	TAX	(\$5.55)	(\$0.28)	(\$5.83)	
														005	TAX	(\$1.24)	(\$0.06)	(\$1.30)	
														004	TAX	(\$9.26)	(\$0.47)	(\$9.73)	
														002	TAX	(\$118.75)	(\$5.93)	(\$124.68)	
Refund																	\$209.18		
BROWN, AARON MICHAEL	BROWN, AARON MICHAEL		4907 SANDTYN DR	WAXHAN, NC 28173	Proration	0089519239	955132	AUTHORIZED	732890970	Refund Generated due to proration on Bill #0089519239-2025-2025-0000-00	Vehicle Sold	3/26/2026	3/27/2026	001	TAX	(\$16.55)	\$0.00	(\$16.55)	
														015	TAX	(\$6.98)	\$0.00	(\$6.98)	
														003	TAX	(\$1.56)	\$0.00	(\$1.56)	
														005	TAX	(\$0.66)	\$0.00	(\$0.66)	
														004	TAX	(\$5.73)	\$0.00	(\$5.73)	
														002	TAX	(\$39.45)	\$0.00	(\$39.45)	
Refund																	\$70.93		
BURG, LOUIS CHARLES	BURG, LOUIS CHARLES	BURG, LINDA SUE	1027 SEVEN SISTERS AVE	MONROE, NC 28110	Proration	0084294229	VD1821	AUTHORIZED	729339528	Refund Generated due to proration on Bill #0084294229-2024-2024-0000-00	Vehicle Sold	3/5/2026	3/6/2026	001	TAX	(\$35.78)	\$0.00	(\$35.78)	
														015	TAX	(\$12.10)	\$0.00	(\$12.10)	
														003	TAX	(\$3.84)	\$0.00	(\$3.84)	
														005	TAX	(\$0.85)	\$0.00	(\$0.85)	
														004	TAX	(\$6.40)	\$0.00	(\$6.40)	
														002	TAX	(\$82.04)	\$0.00	(\$82.04)	
Refund																	\$141.01		
BURNS, CHRISTOPHER CARL	BURNS, CHRISTOPHER CARL		1526 HAWKSTONE DR	WAXHAN, NC 28173	Proration	0079985090	LBT5855	AUTHORIZED	729541092	Refund Generated due to proration on Bill #0079985090-2024-2024-0000-00	Vehicle Sold	3/6/2026	3/9/2026	001	TAX	(\$116.01)	\$0.00	(\$116.01)	
														026	TAX	(\$28.29)	\$0.00	(\$28.29)	
														003	TAX	(\$12.44)	\$0.00	(\$12.44)	
														005	TAX	(\$2.77)	\$0.00	(\$2.77)	
														004	TAX	(\$20.76)	\$0.00	(\$20.76)	
														002	TAX	(\$266.00)	\$0.00	(\$266.00)	
Refund																	\$446.27		



North Carolina Vehicle Tax System

Pending Refund Report

Payee Name	Primary Owner	Secondary Owner	Address 1	Address 2	Address 3	Refund Type	Bill #	Plate Number	Status	Transaction #	Refund Description	Refund Reason	Create Date	Authorization Date	Tax Jurisdiction	Levy Type	Change	Interest Change	Total Change
BYRD, RONALD CURTIS	BYRD, RONALD CURTIS		803 GLADEDALE LN		MONROE, NC 28110	Proration	0083596083	22HCDV	AUTHORIZED	732388770	Refund Generated due to proration on Bill #0083596083-2024-2024-0000-00	Vehicle Sold	3/24/2026	3/25/2026	001	TAX	(\$4.21)	\$0.00	(\$4.21)
															015	TAX	(\$1.42)	\$0.00	(\$1.42)
															003	TAX	(\$0.45)	\$0.00	(\$0.45)
															005	TAX	(\$0.10)	\$0.00	(\$0.10)
															004	TAX	(\$0.75)	\$0.00	(\$0.75)
															002	TAX	(\$9.66)	\$0.00	(\$9.66)
Refund																	\$16.59		
CARPENTER, JANE KNIGHT	CARPENTER, JANE KNIGHT		4034 SAINT JAMES WAY		MONROE, NC 28110	Proration	0079900282	THB5141	AUTHORIZED	850343620	Refund Generated due to proration on Bill #0079900282-2025-2025-0000-00	Vehicle Sold	3/3/2026	3/4/2026	001	TAX	(\$4.21)	(\$0.20)	(\$4.41)
															200	TAX	(\$16.47)	(\$0.82)	(\$17.29)
															200	VEHICLE FEE	\$0.00	\$0.00	\$0.00
															003	TAX	(\$0.40)	(\$0.02)	(\$0.42)
															005	TAX	(\$0.16)	(\$0.01)	(\$0.17)
															004	TAX	(\$1.45)	(\$0.00)	(\$1.55)
002	TAX	(\$10.02)	(\$0.50)	(\$10.52)															
Refund																	\$34.34		
CELENTANO, VINCENT FRANCIS JR	CELENTANO, VINCENT FRANCIS JR		9426 SIR HUON LN		WAXHAM, NC 28173	Proration	0081231146	JMD1947	AUTHORIZED	733840806	Refund Generated due to proration on Bill #0081231146-2025-2025-0000-00	Vehicle Totalled	3/31/2026	4/1/2026	001	TAX	(\$49.67)	\$0.00	(\$49.67)
															026	TAX	(\$13.43)	\$0.00	(\$13.43)
															003	TAX	(\$4.68)	\$0.00	(\$4.68)
															005	TAX	(\$1.99)	\$0.00	(\$1.99)
															004	TAX	(\$17.19)	\$0.00	(\$17.19)
															002	TAX	(\$118.34)	\$0.00	(\$118.34)
Refund																	\$205.30		
CINICOLA, ANTONIO	CINICOLA, ANTONIO		2109 BLUESTONE CT		WAXHAM, NC 28173	Proration	0085322509	TLA8587	AUTHORIZED	973685496	Refund Generated due to proration on Bill #0085322509-2024-2024-0000-00	Vehicle Sold	3/11/2026	3/12/2026	001	TAX	(\$21.56)	\$0.00	(\$21.56)
															500	TAX	(\$50.88)	\$0.00	(\$50.88)
															500	VEHICLE FEE	\$0.00	\$0.00	\$0.00
															028	TAX	(\$6.91)	\$0.00	(\$6.91)
															003	TAX	(\$2.31)	\$0.00	(\$2.31)
															005	TAX	(\$0.51)	\$0.00	(\$0.51)
004	TAX	(\$3.86)	\$0.00	(\$3.86)															
002	TAX	(\$49.45)	\$0.00	(\$49.45)															
Refund																	\$135.48		
CLARK, NATALIE RAE	CLARK, NATALIE RAE	CLARK, JUSTIN EDWARD	6715 MILL GROVE RD		INDIAN TRAIL, NC 28079	Proration	0071657042	CPS6286	AUTHORIZED	733788618	Refund Generated due to proration on Bill #0071657042-2024-2024-0000-00	Vehicle Sold	3/30/2026	3/31/2026	001	TAX	(\$47.24)	\$0.00	(\$47.24)
															023	TAX	(\$14.82)	\$0.00	(\$14.82)
															003	TAX	(\$5.06)	\$0.00	(\$5.06)
															005	TAX	(\$1.13)	\$0.00	(\$1.13)
															004	TAX	(\$8.45)	\$0.00	(\$8.45)
															002	TAX	(\$108.32)	\$0.00	(\$108.32)
Refund																	\$185.02		
COLE, KAYLA WILSON	COLE, KAYLA WILSON		3613 ARTHUR ST		INDIAN TRAIL, NC 28079	Proration	0082717518	FAE2889	AUTHORIZED	728864604	Refund Generated due to proration on Bill #0082717518-2024-2024-0000-00	Vehicle Totalled	3/3/2026	3/4/2026	001	TAX	(\$18.84)	\$0.00	(\$18.84)
															010	TAX	(\$7.37)	\$0.00	(\$7.37)
															003	TAX	(\$2.02)	\$0.00	(\$2.02)
															005	TAX	(\$0.45)	\$0.00	(\$0.45)
															004	TAX	(\$3.37)	\$0.00	(\$3.37)
															002	TAX	(\$43.21)	\$0.00	(\$43.21)
Refund																	\$75.26		
COLLEY, JAMES HARVEY	COLLEY, JAMES HARVEY	COLLEY, GLORIA DELAMAR	PO BOX 2003		INDIAN TRAIL, NC 28079	Adjustment < \$100	0009782172	MBS3169	PENDING	1095997257	Refund Generated due to adjustment on Bill #0009782172-2025-2025-0000	Situs error	3/13/2026		001	TAX	\$0.00	\$0.00	\$0.00
															200	TAX	(\$55.21)	\$0.00	(\$55.21)
															200	VEHICLE FEE	(\$30.00)	\$0.00	(\$30.00)
															800	TAX	\$4.39	\$0.00	\$4.39
															026	TAX	\$3.81	\$0.00	\$3.81
															003	TAX	\$0.00	\$0.00	\$0.00
005	TAX	\$0.00	\$0.00	\$0.00															
004	TAX	\$0.00	\$0.00	\$0.00															
002	TAX	\$0.00	\$0.00	\$0.00															
Refund																	\$77.01		
COURET, RENEE LISA	COURET, RENEE LISA	COURET, CARLOS	2316 MADEIRA CIR		WAXHAM, NC 28173	Proration	0088172576	RDB6112	AUTHORIZED	733841514	Refund Generated due to proration on Bill #0088172576-2025-2025-0000-00	Vehicle Sold	3/31/2026	4/1/2026	001	TAX	(\$25.67)	\$0.00	(\$25.67)
															015	TAX	(\$10.83)	\$0.00	(\$10.83)
															003	TAX	(\$2.42)	\$0.00	(\$2.42)
															005	TAX	(\$1.03)	\$0.00	(\$1.03)
															004	TAX	(\$8.89)	\$0.00	(\$8.89)
															002	TAX	(\$61.17)	\$0.00	(\$61.17)
Refund																	\$110.01		
CRAVEN, LONNIE LAVERN	CRAVEN, LONNIE LAVERN	CRAVEN, DEBBIE WALTERS	218 CANDELLA DR		MATTHEWS, NC 28104	Proration	0084199123	K4KZ	AUTHORIZED	856086287	Refund Generated due to proration on Bill #0084199123-2024-2024-0000-00	Vehicle Sold	3/30/2026	3/31/2026	001	TAX	(\$24.44)	\$0.00	(\$24.44)
															970	TAX	(\$2.47)	\$0.00	(\$2.47)
															026	TAX	(\$5.96)	\$0.00	(\$5.96)
															003	TAX	(\$2.62)	\$0.00	(\$2.62)
															005	TAX	(\$0.58)	\$0.00	(\$0.58)
															004	TAX	(\$4.37)	\$0.00	(\$4.37)
002	TAX	(\$56.04)	\$0.00	(\$56.04)															
Refund																	\$96.48		



North Carolina Vehicle Tax System

Pending Refund Report

Payee Name	Primary Owner	Secondary Owner	Address 1	Address 2	Address 3	Refund Type	Bill #	Plate Number	Status	Transaction #	Refund Description	Refund Reason	Create Date	Authorization Date	Tax Jurisdiction	Levy Type	Change	Interest Change	Total Change															
CRAWFORD, LAMAR WESTERN	CRAWFORD, LAMAR WESTERN		15713 FAIRFIELD DR		MATTHEWS, NC 28184	Proration	0075954854	HD7979R	AUTHORIZED	974487584	Refund Generated due to proration on Bill #0075954854-2025-2025-0000-00	Vehicle Sold	3/16/2026	3/17/2026	001	TAX	(\$6.51)	\$0.00	(\$6.51)															
															700	TAX	(\$10.94)	\$0.00	(\$10.94)															
															700	VEHICLE FEE	(\$25.00)	\$0.00	(\$25.00)															
															023	TAX	(\$2.47)	\$0.00	(\$2.47)															
															003	TAX	(\$0.61)	\$0.00	(\$0.61)															
															005	TAX	(\$0.26)	\$0.00	(\$0.26)															
															004	TAX	(\$2.25)	\$0.00	(\$2.25)															
															002	TAX	(\$15.51)	\$0.00	(\$15.51)															
															Refund																			
															\$63.55																			
CRONIN, RAYMOND ANTHONY	CRONIN, RAYMOND ANTHONY		1634 LOOKOUT CIR		WAXHAW, NC 28173	Proration	0084229044	KKY7127	AUTHORIZED	730470270	Refund Generated due to proration on Bill #0084229044-2024-2024-0000-00	Vehicle Sold	3/12/2026	3/13/2026	001	TAX	(\$91.87)	\$0.00	(\$91.87)															
															026	TAX	(\$22.40)	\$0.00	(\$22.40)															
															003	TAX	(\$9.85)	\$0.00	(\$9.85)															
															005	TAX	(\$2.20)	\$0.00	(\$2.20)															
															004	TAX	(\$16.44)	\$0.00	(\$16.44)															
															002	TAX	(\$210.66)	\$0.00	(\$210.66)															
															Refund																			
															\$353.42																			
															DETOMASO, ANTHONY JOHN II	DETOMASO, ANTHONY JOHN II		2442 OLD CHARLOTTE HWY		MONROE, NC 28110	Proration	0089349944	RLC8397	AUTHORIZED	853580308	Refund Generated due to proration on Bill #0089349944-2025-2025-0000-00	Vehicle Sold	3/19/2026	3/20/2026	001	TAX	(\$3.74)	\$0.00	(\$3.74)
																														200	TAX	(\$14.64)	\$0.00	(\$14.64)
200	VEHICLE FEE	\$0.00	\$0.00	\$0.00																														
003	TAX	(\$0.35)	\$0.00	(\$0.35)																														
005	TAX	(\$0.15)	\$0.00	(\$0.15)																														
004	TAX	(\$1.29)	\$0.00	(\$1.29)																														
002	TAX	(\$8.91)	\$0.00	(\$8.91)																														
Refund																																		
\$29.08																																		
DETOMASO, ANTHONY JOHN II	DETOMASO, ANTHONY JOHN II		2442 OLD CHARLOTTE HWY		MONROE, NC 28110	Proration	0087710243	LEZ5108	AUTHORIZED	853580315	Refund Generated due to proration on Bill #0087710243-2025-2025-0000-00	Vehicle Sold	3/19/2026	3/20/2026																001	TAX	(\$2.75)	\$0.00	(\$2.75)
															200	TAX	(\$10.76)	\$0.00	(\$10.76)															
															200	VEHICLE FEE	\$0.00	\$0.00	\$0.00															
															003	TAX	(\$0.26)	\$0.00	(\$0.26)															
															005	TAX	(\$0.11)	\$0.00	(\$0.11)															
															004	TAX	(\$0.95)	\$0.00	(\$0.95)															
															002	TAX	(\$6.54)	\$0.00	(\$6.54)															
															Refund																			
															\$21.37																			
															DIAS SERVICES LLC	DIAS SERVICES LLC		2000 ALICE FLAGG LANE	12-203	INDIAN TRAIL, NC 28079	Adjustment < \$100	0089525382	MBE5064	PENDING	1095705747	Refund Generated due to adjustment on Bill #0089525382-2025-2025-0000	Situs error	3/12/2026		001	TAX	\$0.00	\$0.00	\$0.00
600	TAX	\$7.65	\$0.00	\$7.65																														
200	TAX	(\$19.80)	\$0.00	(\$19.80)																														
200	VEHICLE FEE	(\$30.00)	\$0.00	(\$30.00)																														
023	TAX	\$1.92	\$0.00	\$1.92																														
003	TAX	\$0.00	\$0.00	\$0.00																														
005	TAX	\$0.00	\$0.00	\$0.00																														
004	TAX	\$0.00	\$0.00	\$0.00																														
002	TAX	\$0.00	\$0.00	\$0.00																														
Refund																																		
\$40.23																																		
DONALDSON, KEVIN DAVID	DONALDSON, KEVIN DAVID		11460 WAKENORTH ST		ORLANDO, FL 32836	Proration	0084224228	KJC2578	AUTHORIZED	731397180	Refund Generated due to proration on Bill #0084224228-2024-2024-0000-00	Reg. Out of state	3/18/2026	3/19/2026	001	TAX	(\$24.94)	\$0.00	(\$24.94)															
															026	TAX	(\$6.08)	\$0.00	(\$6.08)															
															003	TAX	(\$2.67)	\$0.00	(\$2.67)															
															005	TAX	(\$0.60)	\$0.00	(\$0.60)															
															004	TAX	(\$4.46)	\$0.00	(\$4.46)															
															002	TAX	(\$57.19)	\$0.00	(\$57.19)															
															Refund																			
															\$95.94																			
															DURAN, JOSE LUIS FIGUEROA	DURAN, JOSE LUIS FIGUEROA		902 BRUCE THOMAS RD		MONROE, NC 28112	Proration	0084160191	1493CL	AUTHORIZED	731396292	Refund Generated due to proration on Bill #0084160191-2024-2024-0000-00	Vehicle Sold	3/18/2026	3/19/2026	001	TAX	(\$21.90)	\$0.00	(\$21.90)
																														014	TAX	(\$6.82)	\$0.00	(\$6.82)
003	TAX	(\$2.35)	\$0.00	(\$2.35)																														
005	TAX	(\$0.52)	\$0.00	(\$0.52)																														
004	TAX	(\$3.92)	\$0.00	(\$3.92)																														
002	TAX	(\$50.21)	\$0.00	(\$50.21)																														
Refund																																		
\$85.72																																		
ELKAZAZ, USAMA AHMED	ELKAZAZ, USAMA AHMED		211 WILSON ST		MONROE, NC 28112	Adjustment < \$100	0081716936	LFM2505	PENDING	852442304	Refund Generated due to adjustment on Bill #0081716936-2025-2025-0000-00	Over Assessment	3/13/2026																	001	TAX	(\$1.38)	\$0.00	(\$1.38)
																														200	TAX	(\$5.41)	\$0.00	(\$5.41)
															200	VEHICLE FEE	\$0.00	\$0.00	\$0.00															
															003	TAX	(\$0.13)	\$0.00	(\$0.13)															
															005	TAX	(\$0.06)	\$0.00	(\$0.06)															
															004	TAX	(\$0.48)	\$0.00	(\$0.48)															
															002	TAX	(\$3.29)	\$0.00	(\$3.29)															
															Refund																			
															\$10.75																			
															FARRELL, DANA RENEE	FARRELL, DANA RENEE		6105 GRIFFITH RD		MONROE, NC 28112	Proration	0086939344	RKV9675	AUTHORIZED	728865318	Refund Generated due to proration on Bill #0086939344-2025-2025-0000-00	Vehicle Sold	3/3/2026	3/4/2026	001	TAX	(\$0.48)	\$0.00	(\$0.48)
015	TAX	(\$0.20)	\$0.00	(\$0.20)																														
003	TAX	(\$0.05)	\$0.00	(\$0.05)																														
005	TAX	(\$0.02)	\$0.00	(\$0.02)																														
004	TAX	(\$0.17)	\$0.00	(\$0.17)																														
002	TAX	(\$1.14)	\$0.00	(\$1.14)																														
Refund																																		
\$2.06																																		



North Carolina Vehicle Tax System

Pending Refund Report

Payee Name	Primary Owner	Secondary Owner	Address 1	Address 2	Address 3	Refund Type	Bill #	Plate Number	Status	Transaction #	Refund Description	Refund Reason	Create Date	Authorization Date	Tax Jurisdiction	Levy Type	Change	Interest Change	Total Change
FEDAROVICH, ALINA	FEDAROVICH, ALINA		5905 PRESTHICK LN		MONROE, NC 28110	Proration	0089276797	VHX5351	AUTHORIZED	852441457	Refund Generated due to proration on Bill #0089276797-2025-2025-0000-00	Vehicle Sold	3/13/2026	3/16/2026	001	TAX	(\$7.73)	\$0.00	(\$7.73)
															600	TAX	(\$11.69)	\$0.00	(\$11.69)
															023	TAX	(\$2.93)	\$0.00	(\$2.93)
															003	TAX	(\$0.73)	\$0.00	(\$0.73)
															005	TAX	(\$0.31)	\$0.00	(\$0.31)
															004	TAX	(\$2.68)	\$0.00	(\$2.68)
															002	TAX	(\$18.42)	\$0.00	(\$18.42)
Refund																	\$44.49		
FERGUSON, BRANDON WADE	FERGUSON, BRANDON WADE		1565 BANHAM DR		INDIAN TRAIL, NC 28079	Proration	0083354687	RCV6807	AUTHORIZED	851726890	Refund Generated due to proration on Bill #0083354687-2024-2024-0000-00	Vehicle Sold	3/10/2026	3/11/2026	001	TAX	(\$24.84)	\$0.00	(\$24.84)
															200	TAX	(\$76.48)	\$0.00	(\$76.48)
															200	VEHICLE FEE	\$0.00	\$0.00	\$0.00
															003	TAX	(\$2.66)	\$0.00	(\$2.66)
															005	TAX	(\$0.59)	\$0.00	(\$0.59)
															004	TAX	(\$4.44)	\$0.00	(\$4.44)
															002	TAX	(\$56.95)	\$0.00	(\$56.95)
Refund																	\$165.96		
FERNANDEZ, ANDRES RAMON	FERNANDEZ, ANDRES RAMON	FERNANDEZ, CLAUDINE NOEL	2009 YELLOW DAISY DR		MATTHEWS, NC 28104	Proration	0028661145	VZM8809	AUTHORIZED	976517936	Refund Generated due to proration on Bill #0028661145-2025-2025-0000-00	Vehicle Sold	3/24/2026	3/25/2026	001	TAX	(\$1.36)	\$0.00	(\$1.36)
															700	TAX	(\$2.29)	\$0.00	(\$2.29)
															700	VEHICLE FEE	\$0.00	\$0.00	\$0.00
															023	TAX	(\$0.52)	\$0.00	(\$0.52)
															003	TAX	(\$0.13)	\$0.00	(\$0.13)
															005	TAX	(\$0.05)	\$0.00	(\$0.05)
															004	TAX	(\$0.47)	\$0.00	(\$0.47)
002	TAX	(\$3.25)	\$0.00	(\$3.25)															
Refund																	\$8.07		
FREELAND, THOMAS HOOD JR	FREELAND, THOMAS HOOD JR		2900 GOURDVINE DR		MARSHVILLE, NC 28103	Adjustment < \$100	0089535123	RAB7675	PENDING	973960648	Refund Generated due to adjustment on Bill #0089535123-2025-2025-0000	Situs error	3/12/2026		001	TAX	\$0.00	\$0.00	\$0.00
															200	TAX	(\$38.94)	\$0.00	(\$38.94)
															200	VEHICLE FEE	(\$30.00)	\$0.00	(\$30.00)
															018	TAX	\$5.93	\$0.00	\$5.93
															003	TAX	\$0.00	\$0.00	\$0.00
															005	TAX	\$0.00	\$0.00	\$0.00
															004	TAX	\$0.00	\$0.00	\$0.00
002	TAX	\$0.00	\$0.00	\$0.00															
Refund																	\$63.01		
GALVAN DISTRIBUTORS LLC	GALVAN DISTRIBUTORS LLC		TR22 4015 PAGELAND HWY		MONROE, NC 28112	Adjustment < \$100	0089545140	HB02826	PENDING	973960632	Refund Generated due to adjustment on Bill #0089545140-2025-2025-0000	Situs error	3/12/2026		001	TAX	\$0.00	\$0.00	\$0.00
															200	TAX	(\$30.54)	\$0.00	(\$30.54)
															200	VEHICLE FEE	(\$30.00)	\$0.00	(\$30.00)
															014	TAX	\$3.05	\$0.00	\$3.05
															003	TAX	\$0.00	\$0.00	\$0.00
															005	TAX	\$0.00	\$0.00	\$0.00
															004	TAX	\$0.00	\$0.00	\$0.00
002	TAX	\$0.00	\$0.00	\$0.00															
Refund																	\$57.49		
GARCIA, GINIS JOSEPH	GARCIA, GINIS JOSEPH		1008 TOLKA RD		INDIAN TRAIL, NC 28079	Proration	0065361631	DREAMB16	AUTHORIZED	854453068	Refund Generated due to proration on Bill #0065361631-2025-2025-0000-00	Vehicle Sold	3/24/2026	3/25/2026	001	TAX	(\$47.60)	\$0.00	(\$47.60)
															600	TAX	(\$72.00)	\$0.00	(\$72.00)
															026	TAX	(\$12.87)	\$0.00	(\$12.87)
															003	TAX	(\$4.49)	\$0.00	(\$4.49)
															005	TAX	(\$1.91)	\$0.00	(\$1.91)
															004	TAX	(\$16.47)	\$0.00	(\$16.47)
															002	TAX	(\$113.41)	\$0.00	(\$113.41)
Refund																	\$268.75		
GATRELL, DENNIS DEAN	GATRELL, DENNIS DEAN		6117 ABERGELE LN		MATTHEWS, NC 28104	Proration	0063519717	THB9097	AUTHORIZED	976517808	Refund Generated due to proration on Bill #0063519717-2025-2025-0000-00	Vehicle Sold	3/24/2026	3/25/2026	001	TAX	(\$8.54)	\$0.00	(\$8.54)
															700	TAX	(\$14.36)	\$0.00	(\$14.36)
															700	VEHICLE FEE	\$0.00	\$0.00	\$0.00
															023	TAX	(\$3.24)	\$0.00	(\$3.24)
															003	TAX	(\$0.81)	\$0.00	(\$0.81)
															005	TAX	(\$0.34)	\$0.00	(\$0.34)
															004	TAX	(\$2.95)	\$0.00	(\$2.95)
002	TAX	(\$20.35)	\$0.00	(\$20.35)															
Refund																	\$50.59		
GIBSON, KAY HARDLEY	GIBSON, KAY HARDLEY		2675 ROLLING HILLS DR		MONROE, NC 28110	Proration	0081676759	KKH8924	AUTHORIZED	853058766	Refund Generated due to proration on Bill #0081676759-2025-2025-0000-00	Insurance Lapse	3/17/2026	3/18/2026	001	TAX	(\$12.23)	\$0.00	(\$12.23)
															200	TAX	(\$47.88)	\$0.00	(\$47.88)
															200	VEHICLE FEE	\$0.00	\$0.00	\$0.00
															003	TAX	(\$1.15)	\$0.00	(\$1.15)
															005	TAX	(\$0.40)	\$0.00	(\$0.40)
															004	TAX	(\$4.23)	\$0.00	(\$4.23)
															002	TAX	(\$29.14)	\$0.00	(\$29.14)
Refund																	\$95.12		
GOLI, SASIDHAR	GOLI, SASIDHAR		2006 NC-218		INDIAN TRAIL, NC 28079	Adjustment < \$100	0089772090	LF32754	PENDING	1095706143	Refund Generated due to adjustment on Bill #0089772090-2025-2025-0000	Situs error	3/12/2026		001	TAX	\$0.00	\$0.00	\$0.00
															930	TAX	\$2.37	\$0.12	\$2.49
															200	TAX	(\$52.18)	(\$2.61)	(\$54.79)
															200	VEHICLE FEE	(\$30.00)	\$0.00	(\$30.00)
															016	TAX	\$6.70	\$0.34	\$7.04
															003	TAX	\$0.00	\$0.00	\$0.00
															005	TAX	\$0.00	\$0.00	\$0.00
004	TAX	\$0.00	\$0.00	\$0.00															
002	TAX	\$0.00	\$0.00	\$0.00															
Refund																	\$75.26		



North Carolina Vehicle Tax System

Pending Refund Report

Payee Name	Primary Owner	Secondary Owner	Address 1	Address 2	Address 3	Refund Type	Bill #	Plate Number	Status	Transaction #	Refund Description	Refund Reason	Create Date	Authorization Date	Tax Jurisdiction	Levy Type	Change	Interest Change	Total Change															
GOLTI, SASIDHAR	GOLTI, SASIDHAR		2006 NC-218		INDIAN TRAIL, NC 28079	Adjustment < \$100	0081949054	LFJ2754	PENDING	1095706152	Refund Generated due to adjustment on Bill #0081949054-2024-2024-0000	Situs error	3/12/2026		001	TAX	\$0.00	\$0.00	\$0.00															
															930	TAX	\$1.84	\$0.16	\$2.00															
															200	TAX	(\$46.23)	(\$4.05)	(\$50.28)															
															200	VEHICLE FEE	(\$30.00)	\$0.00	(\$30.00)															
															016	TAX	\$5.57	\$0.49	\$6.06															
															003	TAX	\$0.00	\$0.00	\$0.00															
															005	TAX	\$0.00	\$0.00	\$0.00															
															004	TAX	\$0.00	\$0.00	\$0.00															
															002	TAX	\$0.00	\$0.00	\$0.00															
															Refund																	\$72.22		
GONSALVES, DAVID HOWARD JR	GONSALVES, DAVID HOWARD JR		2493 CREEKVIEW DR		WAXHAW, NC 28173	Proration	0071278547	KBN0072	AUTHORIZED	976518384	Refund Generated due to proration on Bill #0071278547-2024-0000-00	Vehicle Sold	3/24/2026	3/25/2026	001	TAX	(\$17.22)	\$0.00	(\$17.22)															
															500	TAX	(\$40.63)	\$0.00	(\$40.63)															
															500	VEHICLE FEE	\$0.00	\$0.00	\$0.00															
															028	TAX	(\$5.52)	\$0.00	(\$5.52)															
															003	TAX	(\$1.85)	\$0.00	(\$1.85)															
															005	TAX	(\$0.41)	\$0.00	(\$0.41)															
															004	TAX	(\$3.08)	\$0.00	(\$3.08)															
															002	TAX	(\$39.49)	\$0.00	(\$39.49)															
															Refund																	\$108.20		
															GOODMAN, PHILIP SCOTT	GOODMAN, PHILIP SCOTT		5096 CAMBRIDGE OAKS DR		MATTHEWS, NC 28104	Proration	0088568121	VHY7307	AUTHORIZED	853811200	Refund Generated due to proration on Bill #0088568121-2025-0000-00	Vehicle Sold	3/20/2026	3/23/2026	001	TAX	(\$178.61)	\$0.00	(\$178.61)
000	TAX	(\$55.62)	\$0.00	(\$55.62)																														
026	TAX	(\$48.31)	\$0.00	(\$48.31)																														
003	TAX	(\$16.84)	\$0.00	(\$16.84)																														
005	TAX	(\$7.15)	\$0.00	(\$7.15)																														
004	TAX	(\$61.81)	\$0.00	(\$61.81)																														
002	TAX	(\$425.55)	\$0.00	(\$425.55)																														
Refund																														\$793.89				
GRIGGS, RANDALL CLIFTON	GRIGGS, RANDALL CLIFTON		310 THREE KNOTTS RD		MONROE, NC 28112	Proration	0088845483	RCGJV	AUTHORIZED	730020528	Refund Generated due to proration on Bill #0088845483-2025-0000-00	Vehicle Sold	3/9/2026	3/10/2026																001	TAX	(\$30.02)	\$0.00	(\$30.02)
																														013	TAX	(\$4.62)	\$0.00	(\$4.62)
															003	TAX	(\$2.83)	\$0.00	(\$2.83)															
															005	TAX	(\$1.20)	\$0.00	(\$1.20)															
															004	TAX	(\$10.39)	\$0.00	(\$10.39)															
															002	TAX	(\$71.54)	\$0.00	(\$71.54)															
															Refund																	\$120.60		
															GRIMM, JOSIAH DANIEL	GRIMM, JOSIAH DANIEL		1039 BEACON AVE		MONROE, NC 28110	Proration	0063014768	FC02881	AUTHORIZED	731191350	Refund Generated due to proration on Bill #0063014768-2025-0000-00	Vehicle Sold	3/17/2026	3/18/2026	001	TAX	(\$3.72)	\$0.00	(\$3.72)
																														026	TAX	(\$1.01)	\$0.00	(\$1.01)
																														003	TAX	(\$0.35)	\$0.00	(\$0.35)
005	TAX	(\$0.15)	\$0.00	(\$0.15)																														
004	TAX	(\$1.29)	\$0.00	(\$1.29)																														
002	TAX	(\$8.88)	\$0.00	(\$8.88)																														
Refund																														\$15.40				
HAGGIN, DAVID SCOTT	HAGGIN, DAVID SCOTT		1713 ROSCOE HOWEY RD	A	WAXHAW, NC 28173	Adjustment < \$100	0089287147	HLA0940	PENDING	973961032	Refund Generated due to adjustment on Bill #0089287147-2025-2025-0000	Situs error	3/12/2026																	001	TAX	\$0.00	\$0.00	\$0.00
																														200	TAX	(\$23.10)	\$0.00	(\$23.10)
																														200	VEHICLE FEE	(\$30.00)	\$0.00	(\$30.00)
															015	TAX	\$2.49	\$0.00	\$2.49															
															003	TAX	\$0.00	\$0.00	\$0.00															
															005	TAX	\$0.00	\$0.00	\$0.00															
															004	TAX	\$0.00	\$0.00	\$0.00															
															002	TAX	\$0.00	\$0.00	\$0.00															
															Refund																	\$50.61		
															HAGGIN, DAVID SCOTT	HAGGIN, DAVID SCOTT		1713 ROSCOE HOWEY RD	A	WAXHAW, NC 28173	Adjustment < \$100	0089287168	EJX4745	PENDING	973961040	Refund Generated due to adjustment on Bill #0089287168-2025-2025-0000	Situs error	3/12/2026		001	TAX	\$0.00	\$0.00	\$0.00
200	TAX	(\$3.52)	(\$0.20)	(\$3.72)																														
200	VEHICLE FEE	(\$30.00)	\$0.00	(\$30.00)																														
015	TAX	\$0.38	\$0.02	\$0.40																														
003	TAX	\$0.00	\$0.00	\$0.00																														
005	TAX	\$0.00	\$0.00	\$0.00																														
004	TAX	\$0.00	\$0.00	\$0.00																														
002	TAX	\$0.00	\$0.00	\$0.00																														
Refund																														\$33.32				
HAMMOND, PATRICIA MARIE	HAMMOND, PATRICIA MARIE		211 WILLOUGHBY RD		MONROE, NC 28110	Proration	0062638112	TH03421	AUTHORIZED	733708102	Refund Generated due to proration on Bill #0062638112-2025-0000-00	Vehicle Sold	3/30/2026	3/31/2026																001	TAX	(\$20.10)	\$0.00	(\$20.10)
															026	TAX	(\$5.44)	\$0.00	(\$5.44)															
															003	TAX	(\$1.90)	\$0.00	(\$1.90)															
															005	TAX	(\$0.80)	\$0.00	(\$0.80)															
															004	TAX	(\$6.95)	\$0.00	(\$6.95)															
															002	TAX	(\$47.80)	\$0.00	(\$47.80)															
															Refund																	\$83.87		
															HANSON, JEFFERY AARON	HANSON, JEFFERY AARON		8909 RED BARONE PL		WAXHAW, NC 28173	Proration	0050395757	7P7136	AUTHORIZED	978452984	Refund Generated due to proration on Bill #0050395757-2024-2024-0000-00	Vehicle Totalled	3/31/2026	4/1/2026	001	TAX	(\$0.30)	\$0.00	(\$0.30)
																														500	TAX	(\$0.70)	\$0.00	(\$0.70)
																														500	VEHICLE FEE	\$0.00	\$0.00	\$0.00
028	TAX	(\$0.10)	\$0.00	(\$0.10)																														
003	TAX	(\$0.03)	\$0.00	(\$0.03)																														
005	TAX	(\$0.01)	\$0.00	(\$0.01)																														
004	TAX	(\$0.05)	\$0.00	(\$0.05)																														
002	TAX	(\$0.68)	\$0.00	(\$0.68)																														
Refund																														\$1.87				



North Carolina Vehicle Tax System

Pending Refund Report

Payee Name	Primary Owner	Secondary Owner	Address 1	Address 2	Address 3	Refund Type	Bill #	Plate Number	Status	Transaction #	Refund Description	Refund Reason	Create Date	Authorization Date	Tax Jurisdiction	Levy Type	Change	Interest Change	Total Change
HAROYAN, VARDUHI	HAROYAN, VARDUHI		5109 CHICKADEE CT	WEDDINGTON, NC 28104	Proration	0057957102	DLF6205	AUTHORIZED	854753144	Refund Generated due to proration on Bill #0057957102-2025-2025-0000-00	Vehicle Sold	3/25/2026	3/26/2026	001	TAX	(\$10.10)	\$0.00	(\$10.10)	
														800	TAX	(\$3.15)	\$0.00	(\$3.15)	
														026	TAX	(\$2.73)	\$0.00	(\$2.73)	
														003	TAX	(\$0.95)	\$0.00	(\$0.95)	
														005	TAX	(\$0.41)	\$0.00	(\$0.41)	
														004	TAX	(\$3.49)	\$0.00	(\$3.49)	
														002	TAX	(\$24.07)	\$0.00	(\$24.07)	
Refund																	\$44.90		
HARRELL, TIMOTHY RYAN	HARRELL, TIMOTHY RYAN		1504 SPRINGFIELD DR	WAXHAW, NC 28173	Proration	0088790007	GPR2EC	AUTHORIZED	850342969	Refund Generated due to proration on Bill #0088790007-2025-2025-0000-00	Vehicle Totalled	3/3/2026	3/4/2026	001	TAX	(\$29.20)	\$0.00	(\$29.20)	
														990	TAX	(\$4.54)	\$0.00	(\$4.54)	
														015	TAX	(\$12.31)	\$0.00	(\$12.31)	
														003	TAX	(\$2.75)	\$0.00	(\$2.75)	
														005	TAX	(\$1.17)	\$0.00	(\$1.17)	
														004	TAX	(\$10.11)	\$0.00	(\$10.11)	
														002	TAX	(\$69.56)	\$0.00	(\$69.56)	
Refund																	\$129.64		
HARRIS, AMY NANCE	HARRIS, AMY NANCE	HARRIS, WILLIAM MILLER JR	9021 BLUJE ROCK RD	INDIAN TRAIL, NC 28079	Proration	0082689078	REA7546	AUTHORIZED	852441968	Refund Generated due to proration on Bill #0082689078-2024-2024-0000-00	Vehicle Totalled	3/13/2026	3/16/2026	001	TAX	(\$8.33)	\$0.00	(\$8.33)	
														990	TAX	(\$1.02)	\$0.00	(\$1.02)	
														016	TAX	(\$3.09)	\$0.00	(\$3.09)	
														003	TAX	(\$0.89)	\$0.00	(\$0.89)	
														005	TAX	(\$0.20)	\$0.00	(\$0.20)	
														004	TAX	(\$1.49)	\$0.00	(\$1.49)	
														002	TAX	(\$19.09)	\$0.00	(\$19.09)	
Refund																	\$34.11		
HARRIS, WILLIAM AMOS JR	HARRIS, WILLIAM AMOS JR	HARRIS, KARY ORMOND	1123 LELAND DR	WESLEY CHAPEL, NC 28104	Proration	0071623852	ZZA4572	AUTHORIZED	852214874	Refund Generated due to proration on Bill #0071623852-2024-2024-0000-00	Vehicle Sold	3/12/2026	3/13/2026	001	TAX	(\$8.53)	(\$0.43)	(\$8.96)	
														970	TAX	(\$0.86)	(\$0.04)	(\$0.90)	
														026	TAX	(\$2.08)	(\$0.18)	(\$2.18)	
														003	TAX	(\$0.92)	(\$0.05)	(\$0.97)	
														005	TAX	(\$0.20)	(\$0.01)	(\$0.21)	
														004	TAX	(\$1.52)	(\$0.07)	(\$1.59)	
														002	TAX	(\$19.57)	(\$0.98)	(\$20.55)	
Refund																	\$35.36		
HELMS, MICHAEL SCOTT	HELMS, MICHAEL SCOTT		3657 HOLLY SCHOOL RD	MARSHVILLE, NC 28103	Proration	0051242292	FMK4230	AUTHORIZED	733786854	Refund Generated due to proration on Bill #0051242292-2024-2024-0000-00	Vehicle Sold	3/30/2026	3/31/2026	001	TAX	(\$4.56)	\$0.00	(\$4.56)	
														017	TAX	(\$1.64)	\$0.00	(\$1.64)	
														003	TAX	(\$0.49)	\$0.00	(\$0.49)	
														005	TAX	(\$0.11)	\$0.00	(\$0.11)	
														004	TAX	(\$0.82)	\$0.00	(\$0.82)	
														002	TAX	(\$10.46)	\$0.00	(\$10.46)	
														Refund					
HILLIARD, ALEX WARREN	HILLIARD, ALEX WARREN		5023 OLD CHARLOTTE HWY	MONROE, NC 28110	Proration	0086809293	9N9316	AUTHORIZED	856148461	Refund Generated due to proration on Bill #0086809293-2025-2025-0000-00	Vehicle Sold	3/31/2026	4/1/2026	001	TAX	(\$5.49)	\$0.00	(\$5.49)	
														000	TAX	(\$0.30)	\$0.00	(\$0.30)	
														019	TAX	(\$2.42)	\$0.00	(\$2.42)	
														003	TAX	(\$0.52)	\$0.00	(\$0.52)	
														005	TAX	(\$0.22)	\$0.00	(\$0.22)	
														004	TAX	(\$1.90)	\$0.00	(\$1.90)	
														002	TAX	(\$13.08)	\$0.00	(\$13.08)	
Refund																	\$31.93		
HOGAN, ASHLEY MEER	HOGAN, ASHLEY MEER		2108 LOUISE DR	MONROE, NC 28112	Proration	0056909744	EED7420	AUTHORIZED	854452949	Refund Generated due to proration on Bill #0056909744-2025-2025-0000-00	Vehicle Sold	3/24/2026	3/25/2026	001	TAX	(\$12.70)	\$0.00	(\$12.70)	
														200	TAX	(\$49.73)	\$0.00	(\$49.73)	
														200	VEHICLE FEE	\$0.00	\$0.00	\$0.00	
														003	TAX	(\$1.20)	\$0.00	(\$1.20)	
														005	TAX	(\$0.51)	\$0.00	(\$0.51)	
														004	TAX	(\$4.39)	\$0.00	(\$4.39)	
														002	TAX	(\$30.27)	\$0.00	(\$30.27)	
Refund																	\$98.80		
HUIZAR, SHANNA MAE	HUIZAR, SHANNA MAE		3103 E BRIEF RD	MONROE, NC 28110	Adjustment < \$100	0083641380	LH47838	PENDING	855322226	Refund Generated due to adjustment on Bill #0083641380-2025-2025-0000-00	Mileage	3/27/2026		001	TAX	(\$7.26)	\$0.00	(\$7.26)	
														930	TAX	(\$1.29)	\$0.00	(\$1.29)	
														016	TAX	(\$3.65)	\$0.00	(\$3.65)	
														003	TAX	(\$0.69)	\$0.00	(\$0.69)	
														005	TAX	(\$0.29)	\$0.00	(\$0.29)	
														004	TAX	(\$2.51)	\$0.00	(\$2.51)	
														002	TAX	(\$17.31)	\$0.00	(\$17.31)	
Refund																	\$33.00		
HUMM, MARY JANE	HUMM, MARY JANE		3316 TAYLOR MORRISON WAY	MONROE, NC 28110	Proration	0086293062	LKC5344	AUTHORIZED	852675929	Refund Generated due to proration on Bill #0086293062-2025-2025-0000-00	Vehicle Totalled	3/16/2026	3/17/2026	001	TAX	(\$7.00)	\$0.00	(\$7.00)	
														970	TAX	(\$1.40)	\$0.00	(\$1.40)	
														026	TAX	(\$1.89)	\$0.00	(\$1.89)	
														003	TAX	(\$0.66)	\$0.00	(\$0.66)	
														005	TAX	(\$0.28)	\$0.00	(\$0.28)	
														004	TAX	(\$2.42)	\$0.00	(\$2.42)	
														002	TAX	(\$16.67)	\$0.00	(\$16.67)	
Refund																	\$30.32		



North Carolina Vehicle Tax System

Pending Refund Report

Payee Name	Primary Owner	Secondary Owner	Address 1	Address 2	Address 3	Refund Type	Bill #	Plate Number	Status	Transaction #	Refund Description	Refund Reason	Create Date	Authorization Date	Tax Jurisdiction	Levy Type	Change	Interest Change	Total Change															
IMANI, MOHAMMADREZA	IMANI, MOHAMMADREZA	NASR ESFAHANI, BEHNAZ	8210 DENHOLME DR	WAXHAW, NC 28173		Proration	0084253834	LCX3621	AUTHORIZED	977523152	Refund Generated due to proration on Bill #0084253834-2024-2024-0000-00	Vehicle Sold	3/27/2026	3/30/2026	001	TAX	(\$7.66)	\$0.00	(\$7.66)															
															500	TAX	(\$18.06)	\$0.00	(\$18.06)															
															500	VEHICLE FEE	\$0.00	\$0.00	\$0.00															
															028	TAX	(\$2.45)	\$0.00	(\$2.45)															
															003	TAX	(\$0.82)	\$0.00	(\$0.82)															
															005	TAX	(\$0.18)	\$0.00	(\$0.18)															
															004	TAX	(\$1.37)	\$0.00	(\$1.37)															
															002	TAX	(\$17.55)	\$0.00	(\$17.55)															
															Refund																			
															\$48.09																			
ISKENDEROVA, KAMILLA	ISKENDEROVA, KAMILLA		955 HARLONS CROSSING DR	WEDDINGTON, NC 28104		Proration	0051227060	TBP5472	AUTHORIZED	855331932	Refund Generated due to proration on Bill #0051227060-2025-2025-0000-00	Vehicle Sold	3/27/2026	3/30/2026	001	TAX	(\$9.88)	\$0.00	(\$9.88)															
															800	TAX	(\$3.08)	\$0.00	(\$3.08)															
															026	TAX	(\$2.68)	\$0.00	(\$2.68)															
															003	TAX	(\$0.93)	\$0.00	(\$0.93)															
															005	TAX	(\$0.40)	\$0.00	(\$0.40)															
															004	TAX	(\$3.42)	\$0.00	(\$3.42)															
															002	TAX	(\$23.56)	\$0.00	(\$23.56)															
															Refund																			
															\$43.95																			
															JAMISON, GARY DWAYNE	JAMISON, GARY DWAYNE	JAMISON, DELORES GILL	3308 CONTINENTAL DR	MONROE, NC 28110		Proration	0081599821	HET6048	AUTHORIZED	854452662	Refund Generated due to proration on Bill #0081599821-2024-2024-0000-00	Vehicle Sold	3/24/2026	3/25/2026	001	TAX	(\$10.24)	\$0.00	(\$10.24)
200	TAX	(\$31.53)	\$0.00	(\$31.53)																														
200	VEHICLE FEE	\$0.00	\$0.00	\$0.00																														
003	TAX	(\$1.10)	\$0.00	(\$1.10)																														
005	TAX	(\$0.24)	\$0.00	(\$0.24)																														
004	TAX	(\$1.83)	\$0.00	(\$1.83)																														
002	TAX	(\$23.48)	\$0.00	(\$23.48)																														
Refund																																		
\$68.42																																		
JONES, BEVERLY ANN	JONES, BEVERLY ANN		5102 OLD CHARLOTTE HWY	MONROE, NC 28110		Proration	0027337682	CAP9001	AUTHORIZED	853500581	Refund Generated due to proration on Bill #0027337682-2024-2024-0000-00	Vehicle Sold	3/19/2026	3/20/2026																001	TAX	(\$0.81)	\$0.00	(\$0.81)
															600	TAX	(\$0.92)	\$0.00	(\$0.92)															
															019	TAX	(\$0.32)	\$0.00	(\$0.32)															
															003	TAX	(\$0.09)	\$0.00	(\$0.09)															
															005	TAX	(\$0.02)	\$0.00	(\$0.02)															
															004	TAX	(\$0.15)	\$0.00	(\$0.15)															
															002	TAX	(\$1.85)	\$0.00	(\$1.85)															
															Refund																			
															\$4.16																			
															KNIGHT, JENNIFER QUICKEL	KNIGHT, JENNIFER QUICKEL	KNIGHT, CHRISTOPHER BRIAN	223 SEVEN OAKS DR	MONROE, NC 28110		Proration	0040495908	BEF8285	AUTHORIZED	731839728	Refund Generated due to proration on Bill #0040495908-2025-2025-0000-00	Vehicle Sold	3/20/2026	3/23/2026	001	TAX	(\$6.04)	\$0.00	(\$6.04)
019	TAX	(\$2.67)	\$0.00	(\$2.67)																														
003	TAX	(\$0.57)	\$0.00	(\$0.57)																														
005	TAX	(\$0.24)	\$0.00	(\$0.24)																														
004	TAX	(\$2.09)	\$0.00	(\$2.09)																														
002	TAX	(\$14.39)	\$0.00	(\$14.39)																														
Refund																																		
\$26.00																																		
KNOWLES, READ MASTERS	KNOWLES, READ MASTERS	KNOWLES, AMANDA HARTON	1216 S FOREST HILLS SCHOO	MARSHVILLE, NC 28103		Proration	0083502971	JEE7201	AUTHORIZED	730020270	Refund Generated due to proration on Bill #0083502971-2024-2024-0000-01	Vehicle Totalled	3/9/2026	3/10/2026																001	TAX	(\$3.34)	\$0.00	(\$3.34)
																														022	TAX	(\$1.75)	\$0.00	(\$1.75)
															003	TAX	(\$0.36)	\$0.00	(\$0.36)															
															005	TAX	(\$0.08)	\$0.00	(\$0.08)															
															004	TAX	(\$0.60)	\$0.00	(\$0.60)															
															002	TAX	(\$7.67)	\$0.00	(\$7.67)															
															Refund																			
															\$13.80																			
															KORIN, EMAD MANSOR-M	KORIN, EMAD MANSOR-M		9008 MAGNA LNTRAIL DR	INDIAN TRAIL, NC 28079		Adjustment < \$100	0089720703	WAW2602	PENDING	1095706386	Refund Generated due to adjustment on Bill #0089720703-2025-2025-0000	Situs error	3/12/2026		001	TAX	\$0.00	\$0.00	\$0.00
																														600	TAX	\$5.25	\$0.00	\$5.25
200	TAX	(\$13.60)	\$0.00	(\$13.60)																														
200	VEHICLE FEE	(\$30.00)	\$0.00	(\$30.00)																														
026	TAX	\$0.94	\$0.00	\$0.94																														
003	TAX	\$0.00	\$0.00	\$0.00																														
005	TAX	\$0.00	\$0.00	\$0.00																														
004	TAX	\$0.00	\$0.00	\$0.00																														
002	TAX	\$0.00	\$0.00	\$0.00																														
Refund																																		
\$37.41																																		
KORRAPATI, RAJENDRA PRASAD	KORRAPATI, RAJENDRA PRASAD		140 ELLISON WAY	MARVIN, NC 28173		Proration	0072934004	WKF9783	AUTHORIZED	973360320	Refund Generated due to proration on Bill #0072934004-2024-2024-0000-00	Vehicle Sold	3/9/2026	3/10/2026	001	TAX	(\$7.90)	\$0.00	(\$7.90)															
															101	TAX	(\$3.87)	\$0.00	(\$3.87)															
															101	VEHICLE FEE	\$0.00	\$0.00	\$0.00															
															026	TAX	(\$1.92)	\$0.00	(\$1.92)															
															003	TAX	(\$0.85)	\$0.00	(\$0.85)															
															005	TAX	(\$0.19)	\$0.00	(\$0.19)															
															004	TAX	(\$1.41)	\$0.00	(\$1.41)															
															002	TAX	(\$18.12)	\$0.00	(\$18.12)															
															Refund																			
															\$34.26																			
LANG, JOHN ERIC	LANG, JOHN ERIC		5422 SILVER CREEK DR	WAXHAW, NC 28173		Proration	0068233654	EHA3524	AUTHORIZED	855332401	Refund Generated due to proration on Bill #0068233654-2025-2025-0000-00	Vehicle Sold	3/27/2026	3/30/2026	001	TAX	(\$17.19)	\$0.00	(\$17.19)															
															970	TAX	(\$3.44)	\$0.00	(\$3.44)															
															015	TAX	(\$7.24)	\$0.00	(\$7.24)															
															003	TAX	(\$1.62)	\$0.00	(\$1.62)															
															005	TAX	(\$0.69)	\$0.00	(\$0.69)															
															004	TAX	(\$5.95)	\$0.00	(\$5.95)															
															002	TAX	(\$40.95)	\$0.00	(\$40.95)															
															Refund																			
															\$77.08																			



North Carolina Vehicle Tax System

Pending Refund Report

Payee Name	Primary Owner	Secondary Owner	Address 1	Address 2	Address 3	Refund Type	Bill #	Plate Number	Status	Transaction #	Refund Description	Refund Reason	Create Date	Authorization Date	Tax Jurisdiction	Levy Type	Change	Interest Change	Total Change
MANTACH, ILYA ALEXANDROVICH	MANTACH, ILYA ALEXANDROVICH		3560 NIMBELL RD		MONROE, NC 28110	Proration	0086305689	TLE2027	AUTHORIZED	859640140	Refund Generated due to proration on Bill #0086305689-2024-2024-0000-00	Vehicle Sold	3/4/2026	3/5/2026	001	TAX	(\$8.47)	\$0.00	(\$8.47)
															200	TAX	(\$26.09)	\$0.00	(\$26.09)
															200	VEHICLE FEE	\$0.00	\$0.00	\$0.00
															003	TAX	(\$0.91)	\$0.00	(\$0.91)
															005	TAX	(\$0.20)	\$0.00	(\$0.20)
															004	TAX	(\$1.52)	\$0.00	(\$1.52)
															002	TAX	(\$19.43)	\$0.00	(\$19.43)
Refund																	\$56.62		
MARWITZ, KURT ALAN	MARWITZ, KURT ALAN		4004 ALDEN ST		LAKE PARK, NC 28079	Proration	0061330028	TMR4539	AUTHORIZED	855038324	Refund Generated due to proration on Bill #0061330028-2024-2024-0000-00	Vehicle Sold	3/26/2026	3/27/2026	001	TAX	(\$24.12)	\$0.00	(\$24.12)
															900	TAX	(\$31.41)	\$0.00	(\$31.41)
															023	TAX	(\$7.56)	\$0.00	(\$7.56)
															003	TAX	(\$2.58)	\$0.00	(\$2.58)
															005	TAX	(\$0.57)	\$0.00	(\$0.57)
															004	TAX	(\$4.31)	\$0.00	(\$4.31)
															002	TAX	(\$55.30)	\$0.00	(\$55.30)
Refund																	\$125.85		
MASON, JULES	MASON, JULES		8721 BEAMINSTER PL		WAXHAM, NC 28173	Proration	0078655716	VDE7193	AUTHORIZED	733788234	Refund Generated due to proration on Bill #0078655716-2024-2024-0000-00	Vehicle Sold	3/30/2026	3/31/2026	001	TAX	(\$0.92)	\$0.00	(\$0.92)
															026	TAX	(\$0.22)	\$0.00	(\$0.22)
															003	TAX	(\$0.10)	\$0.00	(\$0.10)
															005	TAX	(\$0.02)	\$0.00	(\$0.02)
															004	TAX	(\$0.16)	\$0.00	(\$0.16)
															002	TAX	(\$2.11)	\$0.00	(\$2.11)
															Refund				
MASSEY, RONALD	MASSEY, RONALD		3617 WAXHAM INDIAN TRAIL		WAXHAM, NC 28173	Proration	0078240879	KFF5614	AUTHORIZED	977186784	Refund Generated due to proration on Bill #0078240879-2025-2025-0000-00	Vehicle Totalled	3/26/2026	3/27/2026	001	TAX	(\$14.48)	\$0.00	(\$14.48)
															500	TAX	(\$37.36)	\$0.00	(\$37.36)
															500	VEHICLE FEE	\$0.00	\$0.00	\$0.00
															028	TAX	(\$5.92)	\$0.00	(\$5.92)
															003	TAX	(\$1.37)	\$0.00	(\$1.37)
															005	TAX	(\$0.58)	\$0.00	(\$0.58)
															004	TAX	(\$5.01)	\$0.00	(\$5.01)
002	TAX	(\$34.50)	\$0.00	(\$34.50)															
Refund																	\$99.22		
MATSIASH, ALIAKSANDR	MATSIASH, ALIAKSANDR		2712 AUBREY ST		MONROE, NC 28110	Proration	0088217873	RLC7918	AUTHORIZED	851976244	Refund Generated due to proration on Bill #0088217873-2025-2025-0000-00	Vehicle Sold	3/11/2026	3/12/2026	001	TAX	(\$2.70)	\$0.00	(\$2.70)
															200	TAX	(\$10.56)	\$0.00	(\$10.56)
															200	VEHICLE FEE	\$0.00	\$0.00	\$0.00
															003	TAX	(\$0.25)	\$0.00	(\$0.25)
															005	TAX	(\$0.10)	\$0.00	(\$0.10)
															004	TAX	(\$0.93)	\$0.00	(\$0.93)
															002	TAX	(\$6.43)	\$0.00	(\$6.43)
Refund																	\$20.97		
MCCARTER, FRANKIE MAE	MCCARTER, FRANKIE MAE		300 WILSON ST		MONROE, NC 28112	Proration	0088420478	LMP3822	AUTHORIZED	851690308	Refund Generated due to proration on Bill #0088420478-2025-2025-0000-00	Vehicle Totalled	3/9/2026	3/10/2026	001	TAX	(\$21.82)	\$0.00	(\$21.82)
															200	TAX	(\$85.41)	\$0.00	(\$85.41)
															200	VEHICLE FEE	\$0.00	\$0.00	\$0.00
															003	TAX	(\$2.06)	\$0.00	(\$2.06)
															005	TAX	(\$0.87)	\$0.00	(\$0.87)
															004	TAX	(\$7.55)	\$0.00	(\$7.55)
															002	TAX	(\$51.98)	\$0.00	(\$51.98)
Refund																	\$169.69		
MCCONAUGHY, NEIL ALAN	MCCONAUGHY, NEIL ALAN		2024 CLOVER HILL RD		INDIAN TRAIL, NC 28079	Proration	0072382380	ZVX3466	AUTHORIZED	853811042	Refund Generated due to proration on Bill #0072382380-2024-2024-0000-00	Vehicle Sold	3/20/2026	3/23/2026	001	TAX	(\$24.61)	\$0.00	(\$24.61)
															600	TAX	(\$27.90)	\$0.00	(\$27.90)
															026	TAX	(\$6.00)	\$0.00	(\$6.00)
															003	TAX	(\$2.64)	\$0.00	(\$2.64)
															005	TAX	(\$0.59)	\$0.00	(\$0.59)
															004	TAX	(\$4.40)	\$0.00	(\$4.40)
															002	TAX	(\$56.42)	\$0.00	(\$56.42)
Refund																	\$122.56		
MCKEOWN, DEBORA NANCE	MCKEOWN, DEBORA NANCE	MCKEOWN, EDWIN GLENN	2110 STATON RD		MARSHVILLE, NC 28103	Adjustment < \$100	0089358921	LMT9545	PENDING	730664124	Refund Generated due to adjustment on Bill #0089358921-2025-2025-0000-00	Over Assessment	3/13/2026		001	TAX	(\$3.90)	\$0.00	(\$3.90)
															017	TAX	(\$2.48)	\$0.00	(\$2.48)
															003	TAX	(\$0.37)	\$0.00	(\$0.37)
															005	TAX	(\$0.16)	\$0.00	(\$0.16)
															004	TAX	(\$1.35)	\$0.00	(\$1.35)
															002	TAX	(\$9.29)	\$0.00	(\$9.29)
															Refund				
MENDES SOARES, LUCIANE FELIX	MENDES SOARES, LUCIANE FELIX		3507 BROOKSTONE TRL		INDIAN TRAIL, NC 28079	Adjustment < \$100	0089513915	WAN2516	PENDING	1095705774	Refund Generated due to adjustment on Bill #0089513915-2025-2025-0000-00	Situs error	3/12/2026		001	TAX	\$0.00	\$0.00	\$0.00
															600	TAX	\$20.38	\$0.00	\$20.38
															200	TAX	(\$52.76)	\$0.00	(\$52.76)
															200	VEHICLE FEE	(\$30.00)	\$0.00	(\$30.00)
															023	TAX	\$5.12	\$0.00	\$5.12
															003	TAX	\$0.00	\$0.00	\$0.00
															005	TAX	\$0.00	\$0.00	\$0.00
004	TAX	\$0.00	\$0.00	\$0.00															
002	TAX	\$0.00	\$0.00	\$0.00															
Refund																	\$57.26		



North Carolina Vehicle Tax System

Pending Refund Report

Payee Name	Primary Owner	Secondary Owner	Address 1	Address 2	Address 3	Refund Type	Bill #	Plate Number	Status	Transaction #	Refund Description	Refund Reason	Create Date	Authorization Date	Tax Jurisdiction	Levy Type	Change	Interest Change	Total Change
MERRITT, JOHN STEWART JR	MERRITT, JOHN STEWART JR		554 DOVEFIELD DR		INDIAN TRAIL, NC 28079	Proration	0089797408	MBR6554	AUTHORIZED	855039423	Refund Generated due to proration on Bill #0089797408-2025-2025-0000-00	Other Errors	3/26/2026	3/27/2026	001	TAX	(\$73.08)	\$0.00	(\$73.08)
															970	TAX	(\$14.63)	\$0.00	(\$14.63)
															020	TAX	(\$30.04)	\$0.00	(\$30.04)
															003	TAX	(\$6.89)	\$0.00	(\$6.89)
															005	TAX	(\$2.93)	\$0.00	(\$2.93)
															004	TAX	(\$25.29)	\$0.00	(\$25.29)
															002	TAX	(\$174.11)	\$0.00	(\$174.11)
Refund																	\$326.97		
MIESELL, ROBERT HENRY	MIESELL, ROBERT HENRY		1015 ENDERBURY DR		INDIAN TRAIL, NC 28079	Proration	0079115169	REDDE4D	AUTHORIZED	853057653	Refund Generated due to proration on Bill #0079115169-2025-2025-0000-00	Vehicle Sold	3/17/2026	3/18/2026	001	TAX	(\$12.35)	\$0.00	(\$12.35)
															600	TAX	(\$18.68)	\$0.00	(\$18.68)
															023	TAX	(\$4.69)	\$0.00	(\$4.69)
															003	TAX	(\$1.17)	\$0.00	(\$1.17)
															005	TAX	(\$0.50)	\$0.00	(\$0.50)
															004	TAX	(\$4.28)	\$0.00	(\$4.28)
															002	TAX	(\$29.43)	\$0.00	(\$29.43)
Refund																	\$71.10		
MIESELL, TABITHA MICHELLE	MIESELL, TABITHA MICHELLE	MIESELL, ROBERT HENRY	1015 ENDERBURY DR		INDIAN TRAIL, NC 28079	Proration	0082383193	JDE5871	AUTHORIZED	853294862	Refund Generated due to proration on Bill #0082383193-2024-2024-0000-00	Vehicle Sold	3/18/2026	3/19/2026	001	TAX	(\$4.95)	\$0.00	(\$4.95)
															600	TAX	(\$5.61)	\$0.00	(\$5.61)
															023	TAX	(\$1.55)	\$0.00	(\$1.55)
															003	TAX	(\$0.53)	\$0.00	(\$0.53)
															005	TAX	(\$0.12)	\$0.00	(\$0.12)
															004	TAX	(\$0.88)	\$0.00	(\$0.88)
															002	TAX	(\$11.34)	\$0.00	(\$11.34)
Refund																	\$24.98		
MILLER, JORDAN NOEL	MILLER, JORDAN NOEL		215 LIND POINT LN		MONROE, NC 28110	Proration	0083419765	LCX2795	AUTHORIZED	976516984	Refund Generated due to proration on Bill #0083419765-2024-2024-0000-00	Vehicle Totalled	3/24/2026	3/25/2026	001	TAX	(\$11.81)	\$0.00	(\$11.81)
															500	TAX	(\$27.85)	\$0.00	(\$27.85)
															500	VEHICLE FEE	\$0.00	\$0.00	\$0.00
															028	TAX	(\$3.78)	\$0.00	(\$3.78)
															003	TAX	(\$1.27)	\$0.00	(\$1.27)
															005	TAX	(\$0.28)	\$0.00	(\$0.28)
															004	TAX	(\$2.11)	\$0.00	(\$2.11)
002	TAX	(\$27.07)	\$0.00	(\$27.07)															
Refund																	\$74.17		
MILNER, LANCE WILLIAM	MILNER, LANCE WILLIAM		149 BARCLAY DR		WAXHAW, NC 28173	Proration	0030433418	1065TF	AUTHORIZED	978455512	Refund Generated due to proration on Bill #0030433418-2025-2025-0000-00	Vehicle Sold	3/31/2026	4/1/2026	001	TAX	(\$7.79)	\$0.00	(\$7.79)
															500	TAX	(\$20.09)	\$0.00	(\$20.09)
															500	VEHICLE FEE	\$0.00	\$0.00	\$0.00
															028	TAX	(\$3.19)	\$0.00	(\$3.19)
															003	TAX	(\$0.73)	\$0.00	(\$0.73)
															005	TAX	(\$0.31)	\$0.00	(\$0.31)
															004	TAX	(\$2.69)	\$0.00	(\$2.69)
002	TAX	(\$18.55)	\$0.00	(\$18.55)															
Refund																	\$53.35		
MIOC, CLAUDIU SAMUEL	MIOC, CLAUDIU SAMUEL		1413 MEDLIN RD		MONROE, NC 28112	Proration	0088858695	VHV7170	AUTHORIZED	854453173	Refund Generated due to proration on Bill #0088858695-2025-2025-0000-00	Vehicle Sold	3/24/2026	3/25/2026	001	TAX	(\$7.96)	\$0.00	(\$7.96)
															200	TAX	(\$31.17)	\$0.00	(\$31.17)
															200	VEHICLE FEE	\$0.00	\$0.00	\$0.00
															003	TAX	(\$0.75)	\$0.00	(\$0.75)
															005	TAX	(\$0.32)	\$0.00	(\$0.32)
															004	TAX	(\$2.76)	\$0.00	(\$2.76)
															002	TAX	(\$18.97)	\$0.00	(\$18.97)
Refund																	\$61.93		
MISTRY, RAJENDRAKUMAR ZAVERBHAI	MISTRY, RAJENDRAKUMAR ZAVERBHAI		3001 HAMILTON MILL DR		WAXHAW, NC 28173	Proration	0056951199	TFV8451	AUTHORIZED	977187760	Refund Generated due to proration on Bill #0056951199-2025-2025-0000-00	Vehicle Sold	3/26/2026	3/27/2026	001	TAX	(\$3.99)	\$0.00	(\$3.99)
															500	TAX	(\$10.29)	\$0.00	(\$10.29)
															500	VEHICLE FEE	\$0.00	\$0.00	\$0.00
															028	TAX	(\$1.63)	\$0.00	(\$1.63)
															003	TAX	(\$0.37)	\$0.00	(\$0.37)
															005	TAX	(\$0.16)	\$0.00	(\$0.16)
															004	TAX	(\$1.38)	\$0.00	(\$1.38)
002	TAX	(\$9.50)	\$0.00	(\$9.50)															
Refund																	\$27.32		
MISTRY, RAJENDRAKUMAR ZAVERBHAI	MISTRY, RAJENDRAKUMAR ZAVERBHAI		3001 HAMILTON MILL DR		WAXHAW, NC 28173	Proration	0069008892	TLP8654	AUTHORIZED	977187768	Refund Generated due to proration on Bill #0069008892-2025-2025-0000-00	Vehicle Sold	3/26/2026	3/27/2026	001	TAX	(\$3.00)	\$0.00	(\$3.00)
															500	TAX	(\$9.79)	\$0.00	(\$9.79)
															500	VEHICLE FEE	\$0.00	\$0.00	\$0.00
															028	TAX	(\$1.55)	\$0.00	(\$1.55)
															003	TAX	(\$0.36)	\$0.00	(\$0.36)
															005	TAX	(\$0.15)	\$0.00	(\$0.15)
															004	TAX	(\$1.31)	\$0.00	(\$1.31)
002	TAX	(\$9.05)	\$0.00	(\$9.05)															
Refund																	\$26.01		
MOATS, MATTHEW IAN	MOATS, MATTHEW IAN		317 LEAHY MILL CT		MATTHEWS, NC 28104	Proration	0068572998	JHW7341	AUTHORIZED	854453138	Refund Generated due to proration on Bill #0068572998-2025-2025-0000-00	Vehicle Sold	3/24/2026	3/25/2026	001	TAX	(\$14.44)	\$0.00	(\$14.44)
															800	TAX	(\$4.50)	\$0.00	(\$4.50)
															026	TAX	(\$3.91)	\$0.00	(\$3.91)
															003	TAX	(\$1.36)	\$0.00	(\$1.36)
															005	TAX	(\$0.57)	\$0.00	(\$0.57)
															004	TAX	(\$5.00)	\$0.00	(\$5.00)
															002	TAX	(\$34.41)	\$0.00	(\$34.41)
Refund																	\$64.19		



North Carolina Vehicle Tax System

Pending Refund Report

Payee Name	Primary Owner	Secondary Owner	Address 1	Address 2	Address 3	Refund Type	Bill #	Plate Number	Status	Transaction #	Refund Description	Refund Reason	Create Date	Authorization Date	Tax Jurisdiction	Levy Type	Change	Interest Change	Total Change	
MURILLO ROMO, ROSALIA	MURILLO ROMO, ROSALIA		632 SPRING HILL RD		MATTHEWS, NC 28184	Proration	0089286708	VHX4990	AUTHORIZED	973685536	Refund Generated due to proration on Bill #0089286708-2025-2025-0000-00	Vehicle Sold	3/11/2026	3/12/2026	001	TAX	(\$24.66)	\$0.00	(\$24.66)	
															700	TAX	(\$41.46)	\$0.00	(\$41.46)	
															700	VEHICLE FEE	\$0.00	\$0.00	\$0.00	
															020	TAX	(\$10.14)	\$0.00	(\$10.14)	
															003	TAX	(\$2.33)	\$0.00	(\$2.33)	
															005	TAX	(\$0.99)	\$0.00	(\$0.99)	
															004	TAX	(\$8.53)	\$0.00	(\$8.53)	
															002	TAX	(\$58.74)	\$0.00	(\$58.74)	
															Refund					\$146.85
															001	TAX	(\$15.64)	\$0.00	(\$15.64)	
500	TAX	(\$40.35)	\$0.00	(\$40.35)																
500	VEHICLE FEE	\$0.00	\$0.00	\$0.00																
028	TAX	(\$6.40)	\$0.00	(\$6.40)																
003	TAX	(\$1.48)	\$0.00	(\$1.48)																
005	TAX	(\$0.62)	\$0.00	(\$0.62)																
004	TAX	(\$5.42)	\$0.00	(\$5.42)																
002	TAX	(\$37.26)	\$0.00	(\$37.26)																
Refund					\$107.17															
NALI, LOUIS MATTHEW	NALI, LOUIS MATTHEW		1236 SCREECH OWL RD		WAXHAW, NC 28173	Proration	0087925650	VCH3480	AUTHORIZED	972453440	Refund Generated due to proration on Bill #0087925650-2025-2025-0000-00	Vehicle Totalled	3/5/2026	3/6/2026	001	TAX	\$0.00	\$0.00	\$0.00	
															600	TAX	\$7.18	\$0.36	\$7.54	
															200	TAX	(\$19.50)	(\$0.98)	(\$20.48)	
															200	VEHICLE FEE	(\$30.00)	\$0.00	(\$30.00)	
															023	TAX	\$1.99	\$0.10	\$2.09	
															003	TAX	\$0.00	\$0.00	\$0.00	
															005	TAX	\$0.00	\$0.00	\$0.00	
															004	TAX	\$0.00	\$0.00	\$0.00	
															002	TAX	\$0.00	\$0.00	\$0.00	
															Refund					\$40.85
001	TAX	(\$11.84)	\$0.00	(\$11.84)																
017	TAX	(\$7.51)	\$0.00	(\$7.51)																
003	TAX	(\$1.12)	\$0.00	(\$1.12)																
005	TAX	(\$0.47)	\$0.00	(\$0.47)																
004	TAX	(\$4.10)	\$0.00	(\$4.10)																
002	TAX	(\$28.21)	\$0.00	(\$28.21)																
Refund					\$53.25															
NGUYEN, HUNG PHI	NGUYEN, HUNG PHI		2114 KINDER OAK DR		INDIAN TRAIL, NC 28079	Adjustment < \$100	0086590747	RJE2058	PENDING	1895398082	Refund Generated due to adjustment on Bill #0086590747-2024-2024-0000	Situs error	3/11/2026		001	TAX	(\$9.28)	\$0.00	(\$9.28)	
															970	TAX	(\$1.86)	\$0.00	(\$1.86)	
															026	TAX	(\$2.51)	\$0.00	(\$2.51)	
															003	TAX	(\$0.87)	\$0.00	(\$0.87)	
															005	TAX	(\$0.38)	\$0.00	(\$0.38)	
															004	TAX	(\$3.21)	\$0.00	(\$3.21)	
															002	TAX	(\$22.09)	\$0.00	(\$22.09)	
															Refund					\$40.20
															001	TAX	(\$1.02)	\$0.00	(\$1.02)	
															200	TAX	(\$3.14)	\$0.00	(\$3.14)	
200	VEHICLE FEE	\$0.00	\$0.00	\$0.00																
003	TAX	(\$0.11)	\$0.00	(\$0.11)																
005	TAX	(\$0.02)	\$0.00	(\$0.02)																
004	TAX	(\$0.18)	\$0.00	(\$0.18)																
002	TAX	(\$2.34)	\$0.00	(\$2.34)																
Refund					\$6.81															
OTERO, ELVIN JR	OTERO, ELVIN JR		120 CRIMSON DR		PAGELAND, SC 29728	Proration	0085717363	VFL7084	AUTHORIZED	853295352	Refund Generated due to proration on Bill #0085717363-2024-2024-0000-00	Reg. Out of state	3/18/2026	3/19/2026	001	TAX	(\$2.98)	(\$0.16)	(\$3.14)	
															200	TAX	(\$9.18)	(\$0.46)	(\$9.64)	
															200	VEHICLE FEE	\$0.00	\$0.00	\$0.00	
															003	TAX	(\$0.32)	(\$0.01)	(\$0.33)	
															005	TAX	(\$0.07)	\$0.00	(\$0.07)	
															004	TAX	(\$0.53)	(\$0.03)	(\$0.56)	
															002	TAX	(\$6.84)	(\$0.34)	(\$7.18)	
															Refund					\$20.92
															001	TAX	(\$19.23)	\$0.00	(\$19.23)	
															101	TAX	(\$9.43)	\$0.00	(\$9.43)	
101	VEHICLE FEE	\$0.00	\$0.00	\$0.00																
026	TAX	(\$4.69)	\$0.00	(\$4.69)																
003	TAX	(\$2.06)	\$0.00	(\$2.06)																
005	TAX	(\$0.46)	\$0.00	(\$0.46)																
004	TAX	(\$3.44)	\$0.00	(\$3.44)																
002	TAX	(\$44.09)	\$0.00	(\$44.09)																
Refund					\$83.40															
PAPPALARDO, FREDERICK JOSEPH	PAPPALARDO, FREDERICK JOSEPH		1036 SPYGLASS LN		WAXHAW, NC 28173	Proration	0052623063	HBP5244	AUTHORIZED	973687152	Refund Generated due to proration on Bill #0052623063-2024-2024-0000-00	Vehicle Sold	3/11/2026	3/12/2026	001	TAX	(\$7.59)	\$0.00	(\$7.59)	
															028	TAX	(\$3.11)	\$0.00	(\$3.11)	
															003	TAX	(\$0.71)	\$0.00	(\$0.71)	
															005	TAX	(\$0.31)	\$0.00	(\$0.31)	
															004	TAX	(\$2.63)	\$0.00	(\$2.63)	
															002	TAX	(\$18.09)	\$0.00	(\$18.09)	
															Refund					\$32.44



North Carolina Vehicle Tax System

Pending Refund Report

Payee Name	Primary Owner	Secondary Owner	Address 1	Address 2	Address 3	Refund Type	Bill #	Plate Number	Status	Transaction #	Refund Description	Refund Reason	Create Date	Authorization Date	Tax Jurisdiction	Levy Type	Change	Interest Change	Total Change															
PERRY, MATTHEW EDWARD JR	PERRY, MATTHEW EDWARD JR		4864 HENSHAW RD	WAXHAW, NC 28173		Proration	0044891640	XPL8093	AUTHORIZED	973959976	Refund Generated due to proration on Bill #0044891640-2025-2025-0000-00	Vehicle Sold	3/12/2026	3/13/2026	001	TAX	(\$2.47)	\$0.00	(\$2.47)															
															500	TAX	(\$6.36)	\$0.00	(\$6.36)															
															500	VEHICLE FEE	\$0.00	\$0.00	\$0.00															
															028	TAX	(\$1.01)	\$0.00	(\$1.01)															
															003	TAX	(\$0.23)	\$0.00	(\$0.23)															
															005	TAX	(\$0.10)	\$0.00	(\$0.10)															
															004	TAX	(\$0.85)	\$0.00	(\$0.85)															
															002	TAX	(\$5.87)	\$0.00	(\$5.87)															
															Refund																			
															\$16.89																			
PRICE, JAMES RANDOLPH II	PRICE, JAMES RANDOLPH II		3189 DUCK POINT DR	MONROE, NC 28110		Proration	0057103122	BAD55	AUTHORIZED	854754999	Refund Generated due to proration on Bill #0057103122-2024-2024-0000-00	Vehicle Sold	3/25/2026	3/26/2026	001	TAX	(\$5.76)	\$0.00	(\$5.76)															
															200	TAX	(\$17.74)	\$0.00	(\$17.74)															
															200	VEHICLE FEE	\$0.00	\$0.00	\$0.00															
															003	TAX	(\$0.62)	\$0.00	(\$0.62)															
															005	TAX	(\$0.14)	\$0.00	(\$0.14)															
															004	TAX	(\$1.03)	\$0.00	(\$1.03)															
															002	TAX	(\$13.21)	\$0.00	(\$13.21)															
															Refund																			
															\$38.50																			
															PRICE, SEAN CHRISTOPHER	PRICE, SEAN CHRISTOPHER		1406 CIRCLE 5 RANCH RD	MONROE, NC 28112		Proration	0088039912	VP9502	AUTHORIZED	728864976	Refund Generated due to proration on Bill #0088039912-2025-2025-0000-00	Vehicle Sold	3/3/2026	3/4/2026	001	TAX	(\$0.89)	\$0.00	(\$0.89)
029	TAX	(\$0.21)	\$0.00	(\$0.21)																														
003	TAX	(\$0.09)	\$0.00	(\$0.09)																														
005	TAX	(\$0.03)	\$0.00	(\$0.03)																														
004	TAX	(\$0.31)	\$0.00	(\$0.31)																														
002	TAX	(\$2.13)	\$0.00	(\$2.13)																														
Refund																																		
\$3.66																																		
PRINZ, STEVEN RICHARD	PRINZ, STEVEN RICHARD		3012 CORRONA LN	INDIAN TRAIL, NC 28079		Proration	0072078894	ZAPLW	AUTHORIZED	851727919	Refund Generated due to proration on Bill #0072078894-2024-2024-0000-00	Vehicle Sold	3/10/2026	3/11/2026																001	TAX	(\$8.05)	\$0.00	(\$8.05)
																														600	TAX	(\$9.13)	\$0.00	(\$9.13)
															019	TAX	(\$3.15)	\$0.00	(\$3.15)															
															003	TAX	(\$0.86)	\$0.00	(\$0.86)															
															005	TAX	(\$0.19)	\$0.00	(\$0.19)															
															004	TAX	(\$1.44)	\$0.00	(\$1.44)															
															002	TAX	(\$18.46)	\$0.00	(\$18.46)															
															Refund																			
															\$41.28																			
															RAGHAVAN, BALAJI	RAGHAVAN, BALAJI		1008 SUDBURY LN	MATTHEWS, NC 28104		Proration	0076299724	KFM3349	AUTHORIZED	850343669	Refund Generated due to proration on Bill #0076299724-2024-2024-0000-00	Vehicle Totalled	3/3/2026	3/4/2026	001	TAX	(\$11.02)	\$0.00	(\$11.02)
600	TAX	(\$12.49)	\$0.00	(\$12.49)																														
020	TAX	(\$3.61)	\$0.00	(\$3.61)																														
003	TAX	(\$1.18)	\$0.00	(\$1.18)																														
005	TAX	(\$0.26)	\$0.00	(\$0.26)																														
004	TAX	(\$1.97)	\$0.00	(\$1.97)																														
002	TAX	(\$25.27)	\$0.00	(\$25.27)																														
Refund																																		
\$55.00																																		
REICHMAN, ROBERT H	REICHMAN, ROBERT H		1821 PAINTED HORSE DR	INDIAN TRAIL, NC 28079		Proration	0077912782	K3N2540	AUTHORIZED	853811007	Refund Generated due to proration on Bill #0077912782-2024-2024-0000-00	Vehicle Sold	3/20/2026	3/23/2026																001	TAX	(\$11.89)	\$0.00	(\$11.89)
															600	TAX	(\$13.47)	\$0.00	(\$13.47)															
															023	TAX	(\$3.73)	\$0.00	(\$3.73)															
															003	TAX	(\$1.27)	\$0.00	(\$1.27)															
															005	TAX	(\$0.28)	\$0.00	(\$0.28)															
															004	TAX	(\$2.12)	\$0.00	(\$2.12)															
															002	TAX	(\$27.25)	\$0.00	(\$27.25)															
															Refund																			
															\$60.01																			
															RIVERO SOBRINO, DANNAY	RIVERO SOBRINO, DANNAY	POZO FORTEZA, REENDER	1219 VICKIE LN	MATTHEWS, NC 28104		Adjustment < \$100	0059793412	STEPHA	PENDING	976860936	Refund Generated due to adjustment on Bill #0059793412-2025-2025-0000-00	Mileage	3/25/2026		001	TAX	(\$7.23)	\$0.00	(\$7.23)
700	TAX	(\$12.16)	\$0.00	(\$12.16)																														
700	VEHICLE FEE	\$0.00	\$0.00	\$0.00																														
020	TAX	(\$2.97)	\$0.00	(\$2.97)																														
003	TAX	(\$0.68)	\$0.00	(\$0.68)																														
005	TAX	(\$0.29)	\$0.00	(\$0.29)																														
004	TAX	(\$2.50)	\$0.00	(\$2.50)																														
002	TAX	(\$17.23)	\$0.00	(\$17.23)																														
Refund																																		
\$43.06																																		
SALINAS RUBIO, YUVIA ESMERALDA	SALINAS RUBIO, YUVIA ESMERALDA		2907 OLD PAGELAND MARSHVI	WINGATE, NC 28174		Proration	0069069604	HXS207	AUTHORIZED	728865000	Refund Generated due to proration on Bill #0069069604-2025-2025-0000-00	Vehicle Sold	3/3/2026	3/4/2026	001	TAX	(\$11.86)	(\$0.59)	(\$12.45)															
															024	TAX	(\$6.82)	(\$0.34)	(\$7.16)															
															003	TAX	(\$1.12)	(\$0.05)	(\$1.17)															
															005	TAX	(\$0.47)	(\$0.03)	(\$0.50)															
															004	TAX	(\$4.11)	(\$0.21)	(\$4.32)															
															002	TAX	(\$28.26)	(\$1.41)	(\$29.67)															
															Refund																			
															\$55.27																			
															SCHMID, MICHAEL JOHN	SCHMID, MICHAEL JOHN		1321 SAINT REGIS CT	MONROE, NC 28110		Proration	0078101166	HJT4400	AUTHORIZED	850342850	Refund Generated due to proration on Bill #0078101166-2024-2024-0000-00	Vehicle Sold	3/3/2026	3/4/2026	001	TAX	(\$22.72)	\$0.00	(\$22.72)
																														900	TAX	(\$2.78)	\$0.00	(\$2.78)
021	TAX	(\$9.42)	\$0.00	(\$9.42)																														
003	TAX	(\$2.43)	\$0.00	(\$2.43)																														
005	TAX	(\$0.54)	\$0.00	(\$0.54)																														
004	TAX	(\$4.06)	\$0.00	(\$4.06)																														
002	TAX	(\$52.09)	\$0.00	(\$52.09)																														
Refund																																		
\$94.04																																		



North Carolina Vehicle Tax System

Pending Refund Report

Payee Name	Primary Owner	Secondary Owner	Address 1	Address 2	Address 3	Refund Type	Bill #	Plate Number	Status	Transaction #	Refund Description	Refund Reason	Create Date	Authorization Date	Tax Jurisdiction	Levy Type	Change	Interest Change	Total Change
SCHNEIDERMAN, MICHAEL SETH	SCHNEIDERMAN, MICHAEL SETH	SCHNEIDERMAN, ANNA WADDELL	1006 FORBISHIRE DR		MATTHEWS, NC 28184	Proration	0068571701	HEW9738	AUTHORIZED	856086889	Refund Generated due to proration on Bill #0068571701-2025-2025-0000-00	Vehicle Totalled	3/30/2026	3/31/2026	001	TAX	(\$14.02)	\$0.00	(\$14.02)
															600	TAX	(\$21.21)	\$0.00	(\$21.21)
															026	TAX	(\$3.79)	\$0.00	(\$3.79)
															003	TAX	(\$1.32)	\$0.00	(\$1.32)
															005	TAX	(\$0.56)	\$0.00	(\$0.56)
															004	TAX	(\$4.85)	\$0.00	(\$4.85)
															002	TAX	(\$33.41)	\$0.00	(\$33.41)
Refund																	\$79.16		
SEAY, JAMES EDWARD JR	SEAY, JAMES EDWARD JR	SEAY, MELVA DAVIS	PO BOX 543		WINGATE, NC 28174	Proration	0043464396	XVE7546	AUTHORIZED	977522336	Refund Generated due to proration on Bill #0043464396-2025-2025-0000-00	Vehicle Sold	3/27/2026	3/30/2026	001	TAX	(\$6.34)	\$0.00	(\$6.34)
															300	TAX	(\$14.10)	\$0.00	(\$14.10)
															300	VEHICLE FEE	\$0.00	\$0.00	\$0.00
															022	TAX	(\$4.05)	\$0.00	(\$4.05)
															003	TAX	(\$0.60)	\$0.00	(\$0.60)
															005	TAX	(\$0.26)	\$0.00	(\$0.26)
															004	TAX	(\$2.19)	\$0.00	(\$2.19)
002	TAX	(\$15.11)	\$0.00	(\$15.11)															
Refund																	\$42.65		
SHERADEN, CHRISTOPHER DENNIS	SHERADEN, CHRISTOPHER DENNIS		6003 TREMONT DR		INDIAN TRAIL, NC 28079	Proration	0067419329	T0PS	AUTHORIZED	853295653	Refund Generated due to proration on Bill #0067419329-2025-2025-0000-00	Vehicle Sold	3/18/2026	3/19/2026	001	TAX	(\$45.44)	\$0.00	(\$45.44)
															600	TAX	(\$68.72)	\$0.00	(\$68.72)
															023	TAX	(\$17.26)	\$0.00	(\$17.26)
															003	TAX	(\$4.28)	\$0.00	(\$4.28)
															005	TAX	(\$1.82)	\$0.00	(\$1.82)
															004	TAX	(\$15.72)	\$0.00	(\$15.72)
															002	TAX	(\$108.26)	\$0.00	(\$108.26)
Refund																	\$261.50		
SIMMONS, CARL JR	SIMMONS, CARL JR		2007 HAMIL RIDGE DR		WAXHAW, NC 28173	Proration	0062508221	JH4416	AUTHORIZED	974923992	Refund Generated due to proration on Bill #0062508221-2024-2024-0000-00	Insurance Lapse	3/17/2026	3/18/2026	001	TAX	(\$7.42)	\$0.00	(\$7.42)
															500	TAX	(\$17.50)	\$0.00	(\$17.50)
															500	VEHICLE FEE	\$0.00	\$0.00	\$0.00
															028	TAX	(\$2.38)	\$0.00	(\$2.38)
															003	TAX	(\$0.80)	\$0.00	(\$0.80)
															005	TAX	(\$0.18)	\$0.00	(\$0.18)
															004	TAX	(\$1.33)	\$0.00	(\$1.33)
002	TAX	(\$17.01)	\$0.00	(\$17.01)															
Refund																	\$46.62		
SINGH, SUMEET PAL	SINGH, SUMEET PAL		2605 CATESBY DR		WAXHAW, NC 28173	Proration	0084246117	969YSH	AUTHORIZED	733788240	Refund Generated due to proration on Bill #0084246117-2024-2024-0000-00	Vehicle Sold	3/30/2026	3/31/2026	001	TAX	(\$23.45)	\$0.00	(\$23.45)
															026	TAX	(\$5.72)	\$0.00	(\$5.72)
															003	TAX	(\$2.51)	\$0.00	(\$2.51)
															005	TAX	(\$0.56)	\$0.00	(\$0.56)
															004	TAX	(\$4.20)	\$0.00	(\$4.20)
															002	TAX	(\$53.76)	\$0.00	(\$53.76)
															Refund				
SINGHAL, RITESH	SINGHAL, RITESH		407 DEER BRUSH LN		WAXHAW, NC 28173	Proration	0072485512	RDV1737	AUTHORIZED	732388212	Refund Generated due to proration on Bill #0072485512-2024-2024-0000-00	Vehicle Sold	3/24/2026	3/25/2026	001	TAX	(\$37.13)	\$0.00	(\$37.13)
															026	TAX	(\$9.06)	\$0.00	(\$9.06)
															003	TAX	(\$3.98)	\$0.00	(\$3.98)
															005	TAX	(\$0.89)	\$0.00	(\$0.89)
															004	TAX	(\$6.64)	\$0.00	(\$6.64)
															002	TAX	(\$85.15)	\$0.00	(\$85.15)
															Refund				
SLUSHER, LOGAN TAYLOR	SLUSHER, LOGAN TAYLOR		308 GOLDEN VIEW DR		WAXHAW, NC 28173	Proration	0077321482	HB23463	AUTHORIZED	972451616	Refund Generated due to proration on Bill #0077321482-2024-2024-0000-00	Vehicle Sold	3/5/2026	3/6/2026	001	TAX	(\$8.32)	\$0.00	(\$8.32)
															500	TAX	(\$19.62)	\$0.00	(\$19.62)
															500	VEHICLE FEE	\$0.00	\$0.00	\$0.00
															028	TAX	(\$2.67)	\$0.00	(\$2.67)
															003	TAX	(\$0.89)	\$0.00	(\$0.89)
															005	TAX	(\$0.20)	\$0.00	(\$0.20)
															004	TAX	(\$1.49)	\$0.00	(\$1.49)
002	TAX	(\$19.07)	\$0.00	(\$19.07)															
Refund																	\$52.26		
SMITH, VICKIE WAYNE	SMITH, VICKIE WAYNE	SMITH, JANE WRIGHT	6329 SAINT TIMOTHY RD		MARSHVILLE, NC 28103	Proration	0080306531	PBK1788	AUTHORIZED	729340038	Refund Generated due to proration on Bill #0080306531-2025-2025-0000-00	Vehicle Sold	3/5/2026	3/6/2026	001	TAX	(\$20.94)	\$0.00	(\$20.94)
															017	TAX	(\$13.28)	\$0.00	(\$13.28)
															003	TAX	(\$1.97)	\$0.00	(\$1.97)
															005	TAX	(\$0.83)	\$0.00	(\$0.83)
															004	TAX	(\$7.24)	\$0.00	(\$7.24)
															002	TAX	(\$49.88)	\$0.00	(\$49.88)
															Refund				
SPINKS, WESLEY SCOTT	SPINKS, WESLEY SCOTT	SPINKS, AMANDA DAWN	2219 POTTER DOWNS DR		WAXHAW, NC 28173	Proration	0083395102	HB26102	AUTHORIZED	850342094	Refund Generated due to proration on Bill #0083395102-2024-2024-0000-00	Vehicle Sold	3/3/2026	3/4/2026	001	TAX	(\$8.32)	\$0.00	(\$8.32)
															990	TAX	(\$1.07)	\$0.00	(\$1.07)
															015	TAX	(\$2.81)	\$0.00	(\$2.81)
															003	TAX	(\$0.89)	\$0.00	(\$0.89)
															005	TAX	(\$0.20)	\$0.00	(\$0.20)
															004	TAX	(\$1.49)	\$0.00	(\$1.49)
															002	TAX	(\$19.08)	\$0.00	(\$19.08)
Refund																	\$33.86		



North Carolina Vehicle Tax System

Pending Refund Report

Payee Name	Primary Owner	Secondary Owner	Address 1	Address 2	Address 3	Refund Type	Bill #	Plate Number	Status	Transaction #	Refund Description	Refund Reason	Create Date	Authorization Date	Tax Jurisdiction	Levy Type	Change	Interest Change	Total Change
STARNES, TAYLOR COLE	STARNES, TAYLOR COLE		2721 TRINITY CHURCH RD		MONROE, NC 28112	Proration	0089350131	JMF2493	AUTHORIZED	733141716	Refund Generated due to proration on Bill #0089350131-2025-2025-0000-00	Vehicle Sold	3/27/2026	3/30/2026	001	TAX	(\$14.39)	\$0.00	(\$14.39)
															029	TAX	(\$3.42)	\$0.00	(\$3.42)
															003	TAX	(\$1.36)	\$0.00	(\$1.36)
															005	TAX	(\$0.58)	\$0.00	(\$0.58)
															004	TAX	(\$4.98)	\$0.00	(\$4.98)
															002	TAX	(\$34.29)	\$0.00	(\$34.29)
Refund																			\$59.02
STATON, DEBRA ALLEN	STATON, DEBRA ALLEN	ALLEN, DISHEKA ROCHELLE	PO BOX 557		MARSHVILLE, NC 28103	Proration	0088329773	HEJ7064	AUTHORIZED	851690245	Refund Generated due to proration on Bill #0088329773-2025-2025-0000-00	Vehicle Sold	3/9/2026	3/10/2026	001	TAX	(\$11.57)	\$0.00	(\$11.57)
															400	TAX	(\$48.36)	\$0.00	(\$48.36)
															018	TAX	(\$6.89)	\$0.00	(\$6.89)
															003	TAX	(\$1.09)	\$0.00	(\$1.09)
															005	TAX	(\$0.46)	\$0.00	(\$0.46)
															004	TAX	(\$4.00)	\$0.00	(\$4.00)
002	TAX	(\$27.56)	\$0.00	(\$27.56)															
Refund																			\$99.93
STATON, DEBRA ALLEN	STATON, DEBRA ALLEN	ALLEN, DISHEKA ROCHELLE	PO BOX 557		MARSHVILLE, NC 28103	Proration	0076843658	HEJ7064	AUTHORIZED	851690252	Refund Generated due to proration on Bill #0076843658-2024-2024-0000-00	Vehicle Sold	3/9/2026	3/10/2026	001	TAX	(\$1.48)	(\$0.00)	(\$1.56)
															400	TAX	(\$5.00)	(\$0.25)	(\$5.25)
															018	TAX	(\$0.67)	(\$0.03)	(\$0.70)
															003	TAX	(\$0.16)	(\$0.01)	(\$0.17)
															005	TAX	(\$0.04)	\$0.00	(\$0.04)
															004	TAX	(\$0.27)	(\$0.01)	(\$0.28)
002	TAX	(\$3.40)	(\$0.17)	(\$3.57)															
Refund																			\$11.57
TCHIKABERIDZE, DEA	TCHIKABERIDZE, DEA		6602 CONIFER CIR		INDIAN TRAIL, NC 28079	Proration	0068957134	K087907	AUTHORIZED	851975950	Refund Generated due to proration on Bill #0068957134-2025-2025-0000-00	Vehicle Sold	3/11/2026	3/12/2026	001	TAX	(\$16.38)	\$0.00	(\$16.38)
															900	TAX	(\$23.32)	\$0.00	(\$23.32)
															023	TAX	(\$6.22)	\$0.00	(\$6.22)
															003	TAX	(\$1.55)	\$0.00	(\$1.55)
															005	TAX	(\$0.65)	\$0.00	(\$0.65)
															004	TAX	(\$5.67)	\$0.00	(\$5.67)
002	TAX	(\$39.03)	\$0.00	(\$39.03)															
Refund																			\$92.82
THOMAS, AMY WALLACE	THOMAS, AMY WALLACE		4532 ANSONVILLE RD		MARSHVILLE, NC 28103	Proration	0063523288	JAR7790	AUTHORIZED	610323650	Refund Generated due to proration on Bill #0063523288-2025-2025-0000-00	Vehicle Totalled	3/24/2026	3/25/2026	001	TAX	(\$22.00)	\$0.00	(\$22.00)
															003	TAX	(\$2.07)	\$0.00	(\$2.07)
															005	TAX	(\$0.88)	\$0.00	(\$0.88)
															004	TAX	(\$7.62)	\$0.00	(\$7.62)
															002	TAX	(\$52.41)	\$0.00	(\$52.41)
															Refund				
TITTLE, KELLY MONIQUE	TITTLE, KELLY MONIQUE		1036 COUNSELORS DR		MONROE, NC 28110	Proration	0087895229	LCL8592	AUTHORIZED	853811609	Refund Generated due to proration on Bill #0087895229-2025-2025-0000-00	Vehicle Sold	3/20/2026	3/23/2026	001	TAX	(\$19.59)	\$0.00	(\$19.59)
															600	TAX	(\$29.63)	\$0.00	(\$29.63)
															019	TAX	(\$0.64)	\$0.00	(\$0.64)
															003	TAX	(\$1.85)	\$0.00	(\$1.85)
															005	TAX	(\$0.79)	\$0.00	(\$0.79)
															004	TAX	(\$6.77)	\$0.00	(\$6.77)
002	TAX	(\$46.67)	\$0.00	(\$46.67)															
Refund																			\$113.94
WALTERS, AMY LYNN	WALTERS, AMY LYNN		3906 LAKE PARK RD		INDIAN TRAIL, NC 28079	Proration	0087293728	LLM5497	AUTHORIZED	852675733	Refund Generated due to proration on Bill #0087293728-2025-2025-0000-00	Vehicle Sold	3/16/2026	3/17/2026	001	TAX	(\$158.81)	(\$7.94)	(\$166.75)
															900	TAX	(\$226.06)	(\$11.31)	(\$237.37)
															023	TAX	(\$60.33)	(\$3.02)	(\$63.35)
															003	TAX	(\$14.97)	(\$0.74)	(\$15.71)
															005	TAX	(\$6.36)	(\$0.31)	(\$6.67)
															004	TAX	(\$54.96)	(\$2.75)	(\$57.71)
002	TAX	(\$378.37)	(\$18.92)	(\$397.29)															
Refund																			\$944.85
WARD, DOROTHY	WARD, DOROTHY		2020 TWILIGHT LN		MONROE, NC 28110	Proration	0064607426	HEH1953	AUTHORIZED	856147985	Refund Generated due to proration on Bill #0064607426-2025-2025-0000-00	Vehicle Totalled	3/31/2026	4/1/2026	001	TAX	(\$9.22)	\$0.00	(\$9.22)
															600	TAX	(\$13.96)	\$0.00	(\$13.96)
															019	TAX	(\$4.07)	\$0.00	(\$4.07)
															003	TAX	(\$0.87)	\$0.00	(\$0.87)
															005	TAX	(\$0.37)	\$0.00	(\$0.37)
															004	TAX	(\$3.19)	\$0.00	(\$3.19)
002	TAX	(\$21.98)	\$0.00	(\$21.98)															
Refund																			\$53.66
WARD, SARAH BREWER	WARD, SARAH BREWER		10200 FINK RD		MT PLEASANT, NC 28124	Proration	0080364808	3728ST	AUTHORIZED	972722088	Refund Generated due to proration on Bill #0080364808-2025-2025-0000-00	Vehicle Sold	3/6/2026	3/9/2026	001	TAX	(\$32.18)	\$0.00	(\$32.18)
															700	TAX	(\$54.12)	\$0.00	(\$54.12)
															700	VEHICLE FEE	\$0.00	\$0.00	\$0.00
															020	TAX	(\$13.22)	\$0.00	(\$13.22)
															003	TAX	(\$3.03)	\$0.00	(\$3.03)
															005	TAX	(\$1.29)	\$0.00	(\$1.29)
004	TAX	(\$11.14)	\$0.00	(\$11.14)															
002	TAX	(\$76.68)	\$0.00	(\$76.68)															
Refund																			\$191.66



North Carolina Vehicle Tax System

Pending Refund Report

Payee Name	Primary Owner	Secondary Owner	Address 1	Address 2	Address 3	Refund Type	Bill #	Plate Number	Status	Transaction #	Refund Description	Refund Reason	Create Date	Authorization Date	Tax Jurisdiction	Levy Type	Change	Interest Change	Total Change
WATSON, CORY E	WATSON, CORY E		2302 MONARCH PRESERVE CIR		MONROE, NC 28110	Proration	0082841711	RKE1423	AUTHORIZED	853295310	Refund Generated due to proration on Bill #0082841711-2024-2024-0000-00	Vehicle Sold	3/18/2026	3/19/2026	001	TAX	(\$2.30)	\$0.00	(\$2.30)
															200	TAX	(\$7.07)	\$0.00	(\$7.07)
															200	VEHICLE FEE	\$0.00	\$0.00	\$0.00
															003	TAX	(\$0.25)	\$0.00	(\$0.25)
															005	TAX	(\$0.05)	\$0.00	(\$0.05)
															004	TAX	(\$0.41)	\$0.00	(\$0.41)
															002	TAX	(\$5.26)	\$0.00	(\$5.26)
Refund																	\$15.34		
WATTERS, KIRK PATRICK	WATTERS, KIRK PATRICK		1700 MILLBRIDGE PKWY		WAXHAW, NC 28173	Proration	0087413601	LMP5292	AUTHORIZED	978382232	Refund Generated due to proration on Bill #0087413601-2025-2025-0000-00	Vehicle Totalled	3/30/2026	3/31/2026	001	TAX	(\$31.86)	(\$1.60)	(\$33.46)
															500	TAX	(\$82.21)	(\$4.11)	(\$86.32)
															500	VEHICLE FEE	\$0.00	\$0.00	\$0.00
															028	TAX	(\$13.04)	(\$0.65)	(\$13.69)
															003	TAX	(\$3.00)	(\$0.15)	(\$3.15)
															005	TAX	(\$1.27)	(\$0.07)	(\$1.34)
															004	TAX	(\$11.03)	(\$0.55)	(\$11.58)
002	TAX	(\$75.92)	(\$3.79)	(\$79.71)															
Refund																	\$229.25		
WEATHERS BEE, MARGARET SKIDMORE	WEATHERS BEE, MARGARET SKIDMORE		1004 ARDEN DR		MONROE, NC 28112	Proration	0017926325	BCB9579	AUTHORIZED	850342059	Refund Generated due to proration on Bill #0017926325-2024-2024-0000-00	Vehicle Sold	3/3/2026	3/4/2026	001	TAX	(\$0.58)	\$0.00	(\$0.58)
															200	TAX	(\$1.78)	\$0.00	(\$1.78)
															200	VEHICLE FEE	\$0.00	\$0.00	\$0.00
															003	TAX	(\$0.06)	\$0.00	(\$0.06)
															005	TAX	(\$0.01)	\$0.00	(\$0.01)
															004	TAX	(\$0.10)	\$0.00	(\$0.10)
															002	TAX	(\$1.33)	\$0.00	(\$1.33)
Refund																	\$3.86		
WELCHONS, IRVING BLAIR III	WELCHONS, IRVING BLAIR III		2520 MOUNTAIN FOLK LN		WAXHAW, NC 28173	Proration	0075975307	TS9355	AUTHORIZED	733839750	Refund Generated due to proration on Bill #0075975307-2025-2025-0000-00	Vehicle Sold	3/31/2026	4/1/2026	001	TAX	(\$50.36)	\$0.00	(\$50.36)
															028	TAX	(\$20.61)	\$0.00	(\$20.61)
															003	TAX	(\$4.75)	\$0.00	(\$4.75)
															005	TAX	(\$2.02)	\$0.00	(\$2.02)
															004	TAX	(\$17.43)	\$0.00	(\$17.43)
															002	TAX	(\$119.99)	\$0.00	(\$119.99)
															Refund				
WHARTON, STEPHANIE SUE	WHARTON, STEPHANIE SUE		9314 OLD FERRY RD		MONROE, NC 28110	Proration	0086852875	VHM4005	AUTHORIZED	731396478	Refund Generated due to proration on Bill #0086852875-2025-2025-0000-00	Vehicle Sold	3/18/2026	3/19/2026	001	TAX	(\$14.10)	\$0.00	(\$14.10)
															016	TAX	(\$7.09)	\$0.00	(\$7.09)
															003	TAX	(\$1.33)	\$0.00	(\$1.33)
															005	TAX	(\$0.56)	\$0.00	(\$0.56)
															004	TAX	(\$4.88)	\$0.00	(\$4.88)
															002	TAX	(\$33.59)	\$0.00	(\$33.59)
															Refund				
WHEATON, RICHARD EARL II	WHEATON, RICHARD EARL II		9112 OAK BLUFF CT		MARVIN, NC 28173	Proration	0053006055	HCT4227	AUTHORIZED	971819144	Refund Generated due to proration on Bill #0053006055-2024-2024-0000-00	Vehicle Sold	3/3/2026	3/4/2026	001	TAX	(\$7.40)	\$0.00	(\$7.40)
															101	TAX	(\$3.62)	\$0.00	(\$3.62)
															101	VEHICLE FEE	\$0.00	\$0.00	\$0.00
															026	TAX	(\$1.80)	\$0.00	(\$1.80)
															003	TAX	(\$0.79)	\$0.00	(\$0.79)
															005	TAX	(\$0.17)	\$0.00	(\$0.17)
															004	TAX	(\$1.32)	\$0.00	(\$1.32)
002	TAX	(\$16.96)	\$0.00	(\$16.96)															
Refund																	\$32.06		
WILLIAMS, KIMBERLY ANNE	WILLIAMS, KIMBERLY ANNE		1101 MALLARD LANDING DR		MONROE, NC 28110	Proration	0087818681	VHM3437	AUTHORIZED	850895199	Refund Generated due to proration on Bill #0087818681-2025-2025-0000-00	Vehicle Sold	3/5/2026	3/6/2026	001	TAX	(\$15.30)	\$0.00	(\$15.30)
															200	TAX	(\$59.91)	\$0.00	(\$59.91)
															200	VEHICLE FEE	\$0.00	\$0.00	\$0.00
															003	TAX	(\$1.44)	\$0.00	(\$1.44)
															005	TAX	(\$0.61)	\$0.00	(\$0.61)
															004	TAX	(\$5.30)	\$0.00	(\$5.30)
															002	TAX	(\$36.46)	\$0.00	(\$36.46)
Refund																	\$119.02		
WILLIAMS, TAMEERA LASHELLE	WILLIAMS, TAMEERA LASHELLE		100 EXCHANGE CIRLE	APT 302	INDIAN TRAIL, NC 28079	Adjustment < \$100	0089747188	RLN4729	PENDING	1095706422	Refund Generated due to adjustment on Bill #0089747188-2025-2025-0000	Situs error	3/12/2026		001	TAX	\$0.00	\$0.00	\$0.00
															600	TAX	\$29.92	\$0.00	\$29.92
															200	TAX	(\$77.44)	\$0.00	(\$77.44)
															200	VEHICLE FEE	(\$30.00)	\$0.00	(\$30.00)
															020	TAX	\$0.13	\$0.00	\$0.13
															003	TAX	\$0.00	\$0.00	\$0.00
															005	TAX	\$0.00	\$0.00	\$0.00
004	TAX	\$0.00	\$0.00	\$0.00															
002	TAX	\$0.00	\$0.00	\$0.00															
Refund																	\$69.39		
WILLIFORD, ELEANOR DENT	WILLIFORD, ELEANOR DENT		276 DORCHESTER CIR		CLARKSVILLE, TN 37843	Proration	0065682533	FDM5892	AUTHORIZED	853057891	Refund Generated due to proration on Bill #0065682533-2024-2024-0000-00	Reg. Out of state	3/17/2026	3/18/2026	001	TAX	(\$27.26)	\$0.00	(\$27.26)
															200	TAX	(\$83.94)	\$0.00	(\$83.94)
															200	VEHICLE FEE	\$0.00	\$0.00	\$0.00
															003	TAX	(\$2.92)	\$0.00	(\$2.92)
															005	TAX	(\$0.65)	\$0.00	(\$0.65)
															004	TAX	(\$4.88)	\$0.00	(\$4.88)
															002	TAX	(\$62.51)	\$0.00	(\$62.51)
Refund																	\$182.16		



North Carolina Vehicle Tax System

Pending Refund Report

Payee Name	Primary Owner	Secondary Owner	Address 1	Address 2	Address 3	Refund Type	Bill #	Plate Number	Status	Transaction #	Refund Description	Refund Reason	Create Date	Authorization Date	Tax Jurisdiction	Levy Type	Change	Interest Change	Total Change
ZENOSKI, DONALD MARK	ZENOSKI, DONALD MARK		4108 CITATION OAKS CT		WAXHAW, NC 28173	Proration	0070704113	TMY6712	AUTHORIZED	974219816	Refund Generated due to proration on Bill #0070704113-2025- 2025-0000-00	Vehicle Sold	3/13/2026	3/16/2026	001	TAX	(\$4.23)	\$0.00	(\$4.23)
															500	TAX	(\$10.90)	\$0.00	(\$10.90)
															500	VEHICLE FEE	\$0.00	\$0.00	\$0.00
															002	TAX	(\$1.73)	\$0.00	(\$1.73)
															003	TAX	(\$0.39)	\$0.00	(\$0.39)
															005	TAX	(\$0.16)	\$0.00	(\$0.16)
															004	TAX	(\$1.46)	\$0.00	(\$1.46)
															002	TAX	(\$10.06)	\$0.00	(\$10.06)
Refund																	\$28.93		
ZIMMERMAN, EDWARD JEROME	ZIMMERMAN, EDWARD JEROME	ZIMMERMAN, CHRISTINE COLLINS	3704 BRONTE LN		MONROE, NC 28110	Proration	0084625326	LHZ4712	AUTHORIZED	729541128	Refund Generated due to proration on Bill #0084625326-2024- 2024-0000-00	Vehicle Sold	3/6/2026	3/9/2026	001	TAX	(\$14.31)	\$0.00	(\$14.31)
															015	TAX	(\$4.84)	\$0.00	(\$4.84)
															003	TAX	(\$1.53)	\$0.00	(\$1.53)
															005	TAX	(\$0.34)	\$0.00	(\$0.34)
															004	TAX	(\$2.56)	\$0.00	(\$2.56)
															002	TAX	(\$32.80)	\$0.00	(\$32.80)
Refund																	\$56.38		
ZINGER, STEVEN LOUIS	ZINGER, STEVEN LOUIS		1737 CAVAILLON DR		WAXHAW, NC 28173	Proration	0085774724	RDP5594	AUTHORIZED	730664136	Refund Generated due to proration on Bill #0085774724-2024- 2024-0000-00	Vehicle Sold	3/13/2026	3/16/2026	001	TAX	(\$6.47)	(\$0.32)	(\$6.79)
															026	TAX	(\$1.58)	(\$0.08)	(\$1.66)
															003	TAX	(\$0.69)	(\$0.04)	(\$0.73)
															005	TAX	(\$0.15)	(\$0.01)	(\$0.16)
															004	TAX	(\$1.16)	(\$0.06)	(\$1.22)
															002	TAX	(\$14.84)	(\$0.74)	(\$15.58)
Refund																	\$26.14		
Refund Total																	\$12757.29		



Union County, NC

Staff Report

Union County Government
Center
500 North Main Street
Monroe, North Carolina
www.unioncountync.gov

File #: 26-236

Agenda Date: 5/4/2026

TITLE:

South Piedmont Regional Autopsy Center - April 2026 Quarterly Report

INFORMATION CONTACT:

Stephanie Dudley, County Manager's Office, Business Manager, 704-292-2668

ACTION REQUESTED:

None - Information Only.

PRIOR BOARD ACTIONS:

None.

BACKGROUND:

This is the quarterly progress report on the operations of the South Piedmont Regional Autopsy Center (SPRAC).

FINANCIAL IMPACT:

None.

South Piedmont Regional Autopsy Center

April 2026 Quarterly Report

January 2026-March 2026

The South Piedmont Regional Autopsy Center (SPRAC) continues to perform autopsies at its temporary facility located at Atrium Health Union. Service expanded to include Rowan County on January 1, 2026.

Between January 1, 2026, and March 31, 2026, a total of 110 autopsies were performed. Of those, 24 involved deaths in Union County, two in Anson County, 26 in Cabarrus County, three in Montgomery County, nine in Stanly County, 10 in Richmond County, 10 in Moore County, and 26 in Rowan County.

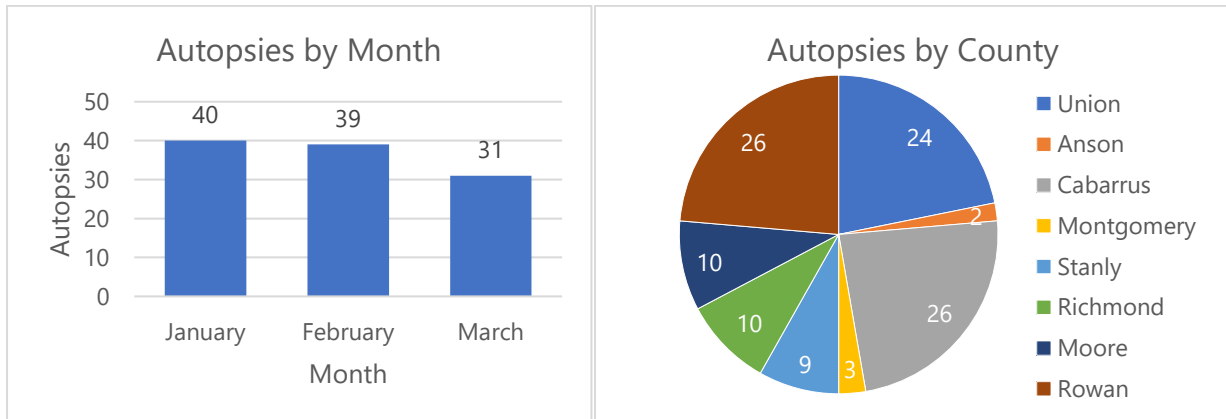

From January through March, 14 cases were connected to criminal investigations, with zero death by distribution cases. This figure is not comprehensive. While the Medical Examiner’s Office works collaboratively with law enforcement, it conducts independent investigations and is not always notified when a criminal investigation occurs.

Planning continues for the permanent facility. Groundbreaking is tentatively scheduled for September 2026. The facility is on track for completion in mid-fiscal year 2028.

SPRAC will continue to evaluate trends in autopsy volume to support efficient operations across all counties served. These insights will guide ongoing decision making as the center expands services and advances planning for the permanent facility.



Union County, NC

Staff Report

Union County Government
Center
500 North Main Street
Monroe, North Carolina
www.unioncountync.gov

File #: 26-243

Agenda Date: 5/4/2026

TITLE:

FY2026 Budget Transfers Reporting - 3rd Quarter

INFORMATION CONTACT:

Blake Hart, Budget & Grants Management, Assistant Director, 704-283-3674

ACTION REQUESTED:

None - Information Only.

PRIOR BOARD ACTIONS:

None.

BACKGROUND:

Per sections XV, XVI, XVII, XVIII, XI, XIX, and XX of the FY 2026 Adopted Operating and Capital Budget Ordinance, management reports the following County Manager Budget Amendments (CMBA) made by the County Manager for the third quarter of fiscal year 2026.

CMBA 11: To transfer funds from the FY 2026 COLA from the central pool for half the fiscal year for General Fund, UC Water, Solid Waste, PC & WC. Approval authority stated in Section XI of the FY 2026 Adopted Operating and Capital Budget Ordinance.

CMBA 12: To transfer funds from Human Services Community Support & Outreach to Facilities Management to correct an overpayment for Christmas Bureau rent and utilities. Approval authority stated in Section XV of the FY 2026 Adopted Operating and Capital Budget Ordinance.

CMBA 13: Recognize and appropriate revenue from the North Carolina Emergency Management (NCEM) State & Local Cybersecurity Grant Program (SLCGP) to purchase a 12-month subscription for penetration testing to identify vulnerabilities and provide clear remediation guidance. Approval authority stated in Section XVIII of the FY 2026 Adopted Operating and Capital Budget Ordinance.

FINANCIAL IMPACT:

None.



Union County, NC

Staff Report

Union County Government
Center
500 North Main Street
Monroe, North Carolina
www.unioncountync.gov

File #: 26-247

Agenda Date: 5/4/2026

TITLE:

Union EMS Quarterly Financial Statements

INFORMATION CONTACT:

Beverly Liles, Finance, Director, 704-283-3675

ACTION REQUESTED:

None - Information Only.

PRIOR BOARD ACTIONS:

None.

BACKGROUND:

Union EMS is required to provide the County with quarterly unaudited financial statements in the terms of the contract agreement with Atrium Health/Union EMS.

FINANCIAL IMPACT:

None.



Union Emergency Medical Services

April 20, 2026

Mr. Brian Matthews, County Manager
Union County
500 North Main St., Suite 901
Monroe N.C. 28112

Mr. Matthews,

In accordance with the Union EMS agreement, enclosed are the unaudited financial statements and the detailed schedules on receivables and liabilities for the period ending March 31, 2026. Please keep in mind when reviewing these statements and schedules that they are prepared on a modified accrual basis. Therefore, there will be timing difference from this basis as compared to a cash basis.

If you have any questions, please contact me at tina.hampton@atriumhealth.org.

Sincerely,

Tina Hampton

Tina Hampton
Director, Financial Services, Atrium Health

CC: Denise White, VP, Facility Executive & Chief Nurse Executive, Atrium Health
Michael Jordan, Chief Operating Officer AHU & AHUW
Kim LaPointe, Area VP Financial Operations NSW Charlotte
David Hyatt, Director, EMS
Beverly Liles, Finance Director
Blake Hart, Budget Director
Patrick Niland, Assistant County Manager

Union Emergency Medical Services

QUARTERLY UNAUDITED FINANCIAL REPORTS

AS OF MARCH 31, 2026

PAGE

1. UNAUDITED STATEMENTS OF ASSETS AND LIABILITIES
2. UNAUDITED COMPARATIVE STATEMENTS OF OPERATIONS
3. UNAUDITED STATEMENTS OF SOURCES AND USES OF CASH
4. ACCOUNT RECEIVABLE AND ACCOUNTS PAYABLE ANALYSIS
5. SCHEDULE OF EXCESS CASH AVAILABLE

UNION EMERGENCY MEDICAL SERVICES
Statements of Assets and Liabilities
March 31, 2026

ASSETS

CURRENT ASSETS	March 2026	June 2025	\$ CHANGE
Cash and cash equivalents	9,049,540	5,727,978	\$3,321,562
Patient accounts receivable - net	1,533,681	1,676,836	(\$143,155)
Other accounts receivable	174,518	14,858	\$159,660
Prepaid expenses	116,574	-	\$116,574
	<u>10,874,313</u>	<u>7,419,672</u>	<u>3,454,641</u>
TOTAL CURRENT ASSETS	<u>10,874,313</u>	<u>7,419,672</u>	<u>3,454,641</u>
TOTAL ASSETS	<u>\$10,874,313</u>	<u>\$7,419,672</u>	<u>\$3,454,641</u>

LIABILITIES AND FUND BALANCE

CURRENT LIABILITIES

Accounts payable	\$3,952,216	\$2,411,102	\$1,541,114
Salaries and Wages Payable	1,438,931	995,009	\$443,922
Curr Port LTD - Notes Payable	-	74,314	(74,314)
Other liabilities and accruals	11,964	57,618	(\$45,654)
Deferred revenue	2,528,890	-	\$2,528,890
	<u>7,932,001</u>	<u>3,538,043</u>	<u>4,393,958</u>
TOTAL CURRENT LIABILITIES	<u>7,932,001</u>	<u>3,538,043</u>	<u>4,393,958</u>
FUND BALANCE			
Unrestricted	2,442,312	3,381,629	(939,317)
Restricted	500,000	500,000	-
	<u>2,942,312</u>	<u>3,881,629</u>	<u>(939,317)</u>
TOTAL FUND BALANCE	<u>2,942,312</u>	<u>3,881,629</u>	<u>(939,317)</u>
TOTAL LIABILITIES AND FUND BALANCE	<u>\$10,874,313</u>	<u>\$7,419,672</u>	<u>\$3,454,641</u>

These statements are prepared on a modified accrual basis and not prepared in accordance with GAAP.

UNION EMERGENCY MEDICAL SERVICES
COMPARATIVE STATEMENTS OF OPERATIONS
For the Month and Year to Date Ended March 31, 2026

CURRENT MONTH			YEAR-TO-DATE			
ACTUAL	BUDGET	%		ACTUAL	BUDGET	%
		CHANGE				CHANGE
OPERATIONS						
OPERATING REVENUE						
\$504,753	\$355,707	42%	Basic Life Support Revenue	\$4,142,806	\$3,201,363	29%
557,592	598,601	-7%	Advanced Life Support Revenue	4,553,320	5,387,409	-15%
225	801	-72%	Other Patient Revenue	4,894	7,209	-32%
167,503	166,090	1%	Mileage Revenue	1,567,398	1,494,810	5%
1,230,073	1,121,199	10%	TOTAL PATIENT REVENUE	10,268,418	10,090,791	2%
577,828	493,317	17%	TOTAL REVENUE DEDUCTIONS	4,390,301	4,439,852	-1%
652,245	627,882	4%	NET PATIENT REVENUE	5,878,117	5,650,939	4%
842,963	842,963	0%	County Funding Revenue	7,586,667	7,586,667	0%
675	2,935	-77%	OTHER OPERATING REVENUE	43,798	26,415	66%
1,495,883	1,473,780	1%	TOTAL OPERATING REVENUE	13,508,582	13,264,021	2%
OPERATING EXPENSES						
947,595	857,129	11%	Salaries & Wages	7,918,429	7,714,161	3%
265,464	293,436	-10%	Benefits	2,013,254	2,640,924	-24%
1,213,059	1,150,565	5%	TOTAL PERSONNEL	9,931,683	10,355,085	-4%
133,230	64,921	105%	Supplies	751,470	584,289	29%
54,385	39,590	37%	Professional Fees	398,357	356,310	12%
16,834	44,600	-62%	Purchased Services	285,848	401,401	-29%
41,531	37,290	11%	Insurance	370,227	335,610	10%
2,454	3,413	-28%	Utilities	41,512	30,717	35%
126,241	133,401	-5%	Other Operating Expense	1,271,979	1,200,609	6%
1,587,734	1,473,780	8%	TOTAL OPERATING EXPENSES	13,051,076	13,264,021	-2%
(91,851)	-	-100%	RESULTS OF OPERATIONS	457,506	-	100%
NON-OPERATING REVENUE (EXPENSE)						
2,292	-	100%	Interest Income	32,399	-	100%
-	-	0%	Interest Expense	(1,931)	-	-100%
2,292	-	100%	TOTAL NON-OPERATING REVENUE (EXPENSE)	30,468	-	100%
CAPITAL						
REVENUE						
-	44,410	-100%	County Funding	-	399,690	-100%
EXPENSES						
-	-	0%	Proceeds from Sale/Disposal of Fixed Assets	38,890	-	100%
(25,216)	-	-100%	Equipment	(402,048)	-	-100%
(569,933)	(44,410)	1183%	Vehicles	(1,064,133)	(399,690)	166%
(595,149)	(44,410)	1240%	Capital Expenses Total	(1,427,291)	(399,690)	257%
(595,149)	-	-100%	TOTAL CAPITAL MARGIN	(1,427,291)	-	-100%
TOTAL MARGIN						
(684,708)	-	-100%	TOTAL MARGIN	(\$939,317)	-	100%
STATISTICS						
1,598	1,480	8%	TRIPS	13,675	13,320	3%

These statements are prepared on a modified accrual basis and not prepared in accordance with GAAP.

UNION EMERGENCY MEDICAL SERVICES

**Statements of Sources and Uses of Cash
For the Year to Date Ended March 31, 2026**

	<u>Y-T-D FY 2026</u>
CASH FLOWS FROM OPERATING ACTIVITIES	
Cash Received from Patients	6,128,116
Cash Received from Union County	10,115,558
Cash Paid for Goods and Services	(4,822,026)
Cash Paid to Employees for Services	(6,635,789)
Net Cash Provided by Operating Activities	<u>4,785,859</u>
CASH FLOWS FROM CAPITAL AND RELATING FINANCING ACTIVITIES	
Purchases of Property and Equipment	(1,466,182)
Proceeds/(Payments) from Notes Payable	(74,314)
Proceeds for Sale of Fixed Assets	38,890
Net Cash Used in Capital and Related Financing Activities	<u>(1,501,606)</u>
CASH FLOWS FROM INVESTING ACTIVITIES	
Interest Income	39,240
Interest Expense	(1,931)
Net Cash Provided by Investing Activities	<u>37,309</u>
NET INCREASE (DECREASE) IN CASH AND CASH EQUIVALENTS	3,321,562
Cash and Equivalents at Beginning of Year	<u>5,727,978</u>
CASH AND CASH EQUIVALENTS - March 31, 2026	<u><u>9,049,540</u></u>
RECONCILIATION OF OPERATING INCOME TO NET CASH PROVIDED BY OPERATING ACTIVITIES	
Operating Income	\$457,506
Adjustments to Reconcile Operating Income to Cash Provided by Operating Activities:	
(Increase) Decrease in Patient Account Receivable, Net	143,155
Change in Other Operating Assets and Liabilities	4,185,198
Net Cash Provided by Operating Activities	<u><u>4,785,859</u></u>

These statements are prepared on a modified accrual basis and not prepared in accordance with GAAP.

Union Emergency Medical Services

MARCH 2026

Quarterly Report on Receivables

Aging of Receivables						
	0-30	31-60	61-90	91-120	over 120	Total
Gross Patient A/R	1,565,962	496,484	307,677	81,495	1,320,678	3,772,296
Other A/R	174,518	-	-	-	-	174,518
Total Receivables	1,740,480	496,484	307,677	81,495	1,320,678	3,946,814
Allowance						(2,238,615)
Net Receivables						1,708,199

Collection Rates		
	Total Billed	Total adjusted Collection Rate
Quarter Ending September 2025	\$3,464,703	58%
Quarter Ending December 2025	\$3,334,989	63%
Quarter Ending March 2026	\$3,468,726	57%
Quarter Ending June 2026	\$0	0%
Fiscal Year to Date	\$10,268,418	59%

Quarterly Report on Payables

Aging of Payables						
	0-30	31-60	61-90	91-120	over 120	Total
Vendor Payables	\$3,952,216	\$0	\$0	\$0	\$0	\$3,952,216
Accrued Payables	\$1,438,931	\$0	\$0	\$0	\$0	\$1,438,931
Current Portion of Notes Payable	\$0	\$0	\$0	\$0	\$0	\$0
Other Liabilities	\$11,964	\$0	\$0	\$0	\$0	\$11,964
Total Liabilities	\$5,403,111	\$0	\$0	\$0	\$0	\$5,403,111

UNION EMS
EXCESS CASH AVAILABLE
For the Month and Year to Date Ended March 31, 2026

Cash & Cash Equivalents	\$9,049,540
Less:	
Accounts Payable	3,952,216
Salaries & Wages Payable	1,438,931
Other Liabilities & Accruals	11,964
Deferred Revenue	2,528,890
TOTAL LIABILITIES	7,932,001
Net Cash from Operations	\$1,117,539
Less: Restricted Fund Balance	500,000
Excess Cash Available Before Capital Committed	\$617,539
2025/2026 Capital Requests:	
Included in Budget	\$532,918
REMAINDER Approved from Excess Funds	
BUDGETED CAPITAL:	
Ambulance - New Builds (Chassis Included) (3)	(\$1,042,626)
Stair Chair (3)	(\$17,100)
Other Misc Equipment	(\$34,347)
Chassis (2)	(\$146,000)
UTV with Trailer	(\$37,028)
EXCESS CASH AVAILABLE	(\$126,644)



Union County, NC

Staff Report

Union County Government
Center
500 North Main Street
Monroe, North Carolina
www.unioncountync.gov

File #: 26-260

Agenda Date: 5/4/2026

TITLE:

Wastewater Treatment Capacity - Monthly Update

INFORMATION CONTACT:

John Shutak, Union County Water, Engineering Director, 704-283-3651

ACTION REQUESTED:

None - Information Only.

PRIOR BOARD ACTIONS:

None.

BACKGROUND:

Union County Water is closely monitoring the wastewater treatment capacities at our Water Reclamation Facilities. Permitting Capacity is evaluated using the Actual Plant Flows plus the Permitted/Obligated Flows (unconnected). Union County Water was asked to provide regular updates. Plant flow information through March 2026 is summarized in the attached table.

Twelve Mile Creek

- Percent of Actual Flows = 69.7%
- Percent of Actual + Permitted Flows = 88.6%
- Actual Flows (MGD) = 5.227
- Actual + Permitted Obligated Flows (MGD) = 6.641

Crooked Creek

- Percent of Actual Flows = 63.7%
- Percent of Actual + Permitted Flows = 88.4%
- Actual Flows (MGD) = 1.211
- Actual + Permitted Obligated Flows (MGD) = 1.680

Olde Sycamore

- Percent of Actual Flows = 26.0%
- Percent of Actual + Permitted Flows = 26.0%
- Actual Flows (MGD) = 0.039
- Actual + Permitted Obligated Flows (MGD) = 0.039

Tallwood

- Percent of Actual Flows = 40.0%

- Percent of Actual + Permitted Flows = 40.0%
- Actual Flows (MGD) = 0.020
- Actual + Permitted Obligated Flows (MGD) = 0.020

Grassy Branch

- Percent of Actual Flows = 76.0%
- Percent of Actual + Permitted Flows = 78.0%
- Actual Flows (MGD) = 0.038
- Actual + Permitted Obligated Flows (MGD) = 0.039

In addition to the wastewater treatment capacities, flow volumes associated with development projects that are in the planning and review process within the Twelve Mile Creek and Crooked Creek WRF service areas are provided for information as well. Development flow volumes through March 2026 are summarized in the attached tables.

FINANCIAL IMPACT:

None.

Water Reclamation Facility Flows

WRF	Permitted Capacity (MGD)	Actual Average Daily Flow ¹ (MGD)	Percent of Actual Flow Used	Actual + Permitted Obligated Flows (MGD)	Percent of Permitted Flow Used	Actual Rainfall (in)
Twelve Mile Creek	7.5	5.227	69.7%	6.641	88.6%	1.3
Crooked Creek	1.9	1.211	63.7%	1.680	88.4%	0.6
Olde Sycamore	0.15	0.039	26.0%	0.039	26.0%	0.7
Tallwood	0.05	0.020	40.0%	0.020	40.0%	0.9
Grassy Branch	0.05	0.038	76.0%	0.039	78.0%	0.9

¹Based on a 12-month rolling average.

Development Flows

12-Mile Creek WRF		
Backlog Type	Number of Projects	Requested Flow (MGD)
Approved – Permit Submittal Pending	5	0.280
Engineering Plan Review	15	0.380
Sketch Plan Review	11	0.363
Totals	31	1.023

Crooked Creek WRF		
Backlog Type	Number of Projects	Requested Flow (MGD)
Approved – Permit Submittal Pending	5	0.129
Engineering Plan Review	5	0.173
Sketch Plan Review	8	0.152
Totals	18	0.454



Union County, NC

Staff Report

Union County Government
Center
500 North Main Street
Monroe, North Carolina
www.unioncountync.gov

File #: 26-261

Agenda Date: 5/4/2026

TITLE:

March 2026 Union County Public Schools Monthly Report

INFORMATION CONTACT:

Beverly Liles, Finance, Director, 704-283-3675

ACTION REQUESTED:

None - Information Only.

PRIOR BOARD ACTIONS:

None.

BACKGROUND:

This is the monthly report from UCPS as required by the Budget Ordinance.

FINANCIAL IMPACT:

None.

FINANCE DIVISION

To: Beverly Liles
From: Shanna McLamb
Date: April 20, 2026
RE: Monthly Reporting – Ordinance Sections XXIII

Pursuant to the requested information included in the BOCC annual budget ordinance, the below information has been provided to satisfy the requirements for monthly reporting. Notes have been provided for each requested item to provide explanation for items that are currently unavailable or incomplete due reporting capabilities related to the state software migration.

FY2026 Ordinance Section XXIII - as it appears in the ordinance document

In accordance with the NCGS §115C-429(c), the Board of County Commissioners calls for, for FY 2026, the books, records, audit reports, and other information bearing on the financial operation of UCPS listed below to be made available to the Board of Commissioners as set forth herein. Each of the monthly reports and counts described below is called for within ten business days of the close of each month, beginning with the close of July 2025.

- (a) A monthly report of monthly and cumulative revenues and expenditures, by function code, for all funds by fund. In addition, the original adopted budget and revised or amended budget for revenues and expenditures, by function code.
- (b) A monthly report of monthly expenditures, by project for appropriations outlined in section XXII and "Capital Projects Ordinance", including a brief summary of the status of the project.
- (c) A monthly report of monthly expenditures, by project for all other capital projects, including a brief summary of the status of the project.
- (d) A monthly report of transfers between function codes for all funds by fund. NOTE: There is no information to provide at this time.
- (e) A monthly personnel count of locally funded employees and state funded employees broken down by function code from which they are paid, furthermore, the Board of County Commissioners requests not to receive the payroll records in response to this request.
- (f) A monthly ADM count.

Thank you.

CC: Andrew G. Houlihan
Brian Matthews

Union County Public Schools
YTD Budget Report
March 31, 2026

FUND	F1	Type2	2digPu	Purpose Description	Values			
					Current Budget	YTD Rev/Exp	Encumb & Req	Rem Budget
10	State	Expense	51	Regular Instructions Services	\$185,528,352.58	\$136,860,935.71	\$932,125.47	\$47,735,291.40
			52	Special Populations Services	\$44,834,642.98	\$34,949,621.91	\$1,086,399.02	\$8,798,622.05
			53	Alternative Programs and Services	\$5,001,792.25	\$2,828,555.54	\$943.34	\$2,172,893.37
			54	School Leadership Services	\$12,725,067.44	\$9,717,944.10	\$1,594.68	\$3,005,528.66
			55	Co-Curricular Services	\$6,987.53	\$0.00	\$0.00	\$6,987.53
			58	School-Based Support Services	\$12,726,237.03	\$14,523,677.28	\$128,328.35	\$1,925,768.60
			61	Support and Development Services	\$350,816.98	\$189,338.17	\$533.75	\$160,945.06
			62	Special Population Support and Development Services	\$346,291.08	\$124,929.05	\$0.00	\$221,362.03
			63	Alternative Programs and Services Support and Development Services	\$4,522.22	\$0.00	\$0.00	\$4,522.22
			64	Technology Support Services	\$2,088,003.73	\$440,276.32	\$26,756.61	\$1,620,970.80
			65	Operational Support Services	\$36,708,302.99	\$25,898,401.18	\$504,817.36	\$10,305,084.45
			66	Financial and Human Resource Services	\$338,362.30	\$130,384.23	\$0.00	\$207,978.07
			67	Accountability Services	\$1,118.63	\$0.00	\$0.00	\$1,118.63
			68	System-Wide Pupil Support Services	\$14,073.29	\$0.00	\$0.00	\$14,073.29
			69	Policy, Leadership and Public Relations Services	\$641,449.09	\$443,725.59	\$0.00	\$197,723.50
			71	Community Services	\$0.00	\$0.00	\$0.00	\$0.00
			72	Nutrition Services	\$1,586.00	\$133,096.66	\$0.00	-\$131,510.66
			81	Payments to Other Governmental Units	\$0.00	-\$8,845.29	\$0.00	\$8,845.29
			84	Unbudgeted Funds	\$0.00	\$0.00	\$0.00	\$0.00
		Expense Total			\$301,317,606.12	\$226,232,040.45	\$2,680,898.58	\$72,404,667.09
		Revenue			-\$301,317,606.12	-\$226,280,127.12	\$0.00	-\$75,037,479.00
		Revenue Total		Other State Allocations for Current Operations	-\$301,317,606.12	-\$226,280,127.12	\$0.00	-\$75,037,479.00
		State Total			\$0.00	-\$48,086.67	\$2,680,898.58	-\$2,632,811.91
10	Total				\$0.00	-\$48,086.67	\$2,680,898.58	-\$2,632,811.91
20	Local	Expense	51	Regular Instructions Services	\$32,962,731.00	\$32,094,895.29	\$3,458,849.79	\$2,591,014.08
			52	Special Populations Services	\$6,100,949.00	\$4,554,680.05	\$21,772.47	\$1,524,496.48
			53	Alternative Programs and Services	\$5,413,543.00	\$2,888,936.25	\$16,316.47	\$2,508,290.28
			54	School Leadership Services	\$15,125,578.50	\$11,037,337.36	\$150,856.58	\$3,937,384.56
			55	Co-Curricular Services	\$2,468,938.00	\$1,711,070.12	\$20,988.82	\$736,879.06
			58	School-Based Support Services	\$10,571,700.12	\$7,927,565.30	\$293,420.54	\$2,350,714.28
			61	Support and Development Services	\$3,177,252.50	\$2,250,728.82	\$12,745.95	\$913,777.73
			62	Special Population Support and Development Services	\$408,978.00	\$468,061.72	\$0.00	-\$59,083.72
			63	Alternative Programs and Services Support and Development Services	\$176,490.00	\$123,831.11	\$0.00	\$52,658.89
			64	Technology Support Services	\$4,400,087.88	\$3,422,775.58	\$47,385.18	\$929,927.12
			65	Operational Support Services	\$29,921,087.00	\$21,536,165.61	\$1,562,720.12	\$6,822,201.27
			66	Financial and Human Resource Services	\$9,360,881.00	\$7,121,925.03	\$399,953.67	\$1,839,002.30
			67	Accountability Services	\$636,630.00	\$368,641.38	\$32,173.53	\$235,815.09
			68	System-Wide Pupil Support Services	\$584,660.00	\$537,641.66	\$52,751.04	-\$5,732.70
			69	Policy, Leadership and Public Relations Services	\$3,804,770.00	\$2,776,212.06	\$116,227.81	\$912,330.13
			71	Community Services	\$135,000.00	\$386.58	\$0.00	\$134,613.42
			72	Nutrition Services	\$442,377.00	\$208,423.38	\$0.00	\$233,953.62
			81	Payments to Other Governmental Units	\$14,517,960.00	\$10,133,886.70	\$0.00	\$4,384,073.30
			86	Educational Foundations	\$0.00	\$0.00	\$0.00	\$0.00
			84	Unbudgeted Funds	\$0.00	\$0.00	\$0.00	\$0.00
		Expense Total			\$140,209,613.00	\$109,163,164.00	\$6,186,161.97	\$24,860,287.03
		Revenue			-\$140,209,613.00	-\$105,411,897.27	\$0.00	-\$34,797,715.73
		Revenue Total		Local Sources - Unrestricted	-\$140,209,613.00	-\$105,411,897.27	\$0.00	-\$34,797,715.73
20	Total				\$0.00	\$3,751,266.73	\$6,186,161.97	-\$9,937,428.70
		State Total			\$0.00	\$3,751,266.73	\$6,186,161.97	-\$9,937,428.70

Union County Public Schools
YTD Budget Report
March 31, 2026

FUND	F1	Type2	2digPu	Purpose Description	Current Budget	YTD Rev/Exp	Encumb & Req	Rem Budget
30	Federal	Expense	51	Regular Instructions Services	\$1,537,706.57	\$770,203.78	\$144,135.12	\$623,367.67
			52	Special Populations Services	\$11,281,112.19	\$4,729,321.76	\$0.00	\$6,551,790.43
			53	Alternative Programs and Services	\$7,038,246.72	\$3,344,299.56	\$365,465.49	\$3,328,481.67
			54	School Leadership Services	\$136,683.17	\$36,683.17	\$0.00	\$100,000.00
			55	Co-Curricular Services	\$0.00	\$0.00	\$0.00	\$0.00
			58	School-Based Support Services	\$1,182,359.02	\$586,534.54	\$125,135.17	\$470,689.31
			61	Support and Development Services	\$35,149.64	\$56,537.87	\$0.00	-\$21,388.23
			62	Special Population Support and Development Services	\$256,169.89	\$157,512.33	\$0.00	\$98,657.56
			63	Alternative Programs and Services Support and Development Services	\$198,901.54	\$92,208.35	\$0.00	\$106,693.19
			64	Technology Support Services	\$0.00	\$0.00	\$0.00	\$0.00
			65	Operational Support Services	\$306,958.91	\$1,958.91	\$0.00	\$305,000.00
			66	Financial and Human Resource Services	\$0.00	\$0.00	\$0.00	\$0.00
			67	Accountability Services	\$0.00	\$0.00	\$0.00	\$0.00
			68	System-Wide Pupil Support Services	\$0.00	\$0.00	\$0.00	\$0.00
			69	Policy, Leadership and Public Relations Services	\$0.00	\$0.00	\$0.00	\$0.00
			71	Community Services	\$0.00	\$0.00	\$0.00	\$0.00
			72	Nutrition Services	\$0.00	\$0.00	\$0.00	\$0.00
			81	Payments to Other Governmental Units	\$890,214.75	\$181,958.95	\$0.00	\$708,255.80
			82	Unbudgeted Funds	\$1,372,811.31	\$0.00	\$0.00	\$1,372,811.31
		Expense Total			\$24,236,313.71	\$9,957,219.22	\$634,735.78	\$13,644,358.71
		Revenue	33	Other State Allocations for Current Operations	-\$24,236,313.71	-\$9,957,250.07	\$0.00	-\$14,279,063.64
		Revenue Total	44	Local Sources - Unrestricted	-\$24,236,313.71	-\$9,957,250.07	\$0.00	-\$14,279,063.64
		Federal Total			\$0.00	-\$30.85	\$634,735.78	-\$634,704.93
30	Total				\$0.00	-\$30.85	\$634,735.78	-\$634,704.93
40	Capital	Expense	51	Regular Instructions Services	\$4,490,753.00	\$2,521,249.05	\$1,766,661.50	\$202,842.45
			52	Special Populations Services	\$0.00	\$3,585.86	\$0.00	-\$3,585.86
			53	Alternative Programs and Services	\$0.00	\$0.00	\$0.00	\$0.00
			54	School Leadership Services	\$0.00	\$0.00	\$0.00	\$0.00
			55	Co-Curricular Services	\$8,108,217.65	\$158,215.66	\$208,098.63	\$7,741,903.36
			58	School-Based Support Services	\$0.00	\$0.00	\$0.00	\$0.00
			64	Technology Support Services	\$0.00	\$98,524.64	\$354,899.77	-\$453,424.41
			65	Operational Support Services	\$6,870,166.94	\$1,444,381.99	\$5,446,401.63	-\$20,616.68
			69	Policy, Leadership and Public Relations Services	\$0.00	\$6,804.29	\$849.35	-\$7,653.64
			72	Nutrition Services	\$250,000.00	\$0.00	\$0.00	\$250,000.00
			90	Capital Outlay	\$104,911,323.67	\$24,168,603.44	\$31,882,772.04	\$48,859,948.19
			83	Unbudgeted Funds	\$0.00	\$0.00	\$0.00	\$0.00
			91	Capital Outlay	\$0.00	\$0.00	\$0.00	\$0.00
			92	Capital Outlay	\$0.00	\$0.00	\$0.00	\$0.00
		Expense Total			\$124,630,461.26	\$28,401,364.93	\$39,659,682.92	\$56,569,413.41
		Revenue	33	Other State Allocations for Current Operations	-\$13,035,701.62	-\$11,043.62	\$0.00	-\$13,024,658.00
		Revenue Total	44	Local Sources - Unrestricted	-\$111,594,759.64	-\$28,810,382.62	\$0.00	-\$82,784,377.02

Union County Public Schools
YTD Budget Report
March 31, 2026

FUND	F1	Type2	2digPu	Purpose Description	Current Budget	YTD Rev/Exp	Encumb & Req	Rem Budget
40	Capital	Revenue Total			-\$124,630,461.26	-\$28,821,426.24	\$0.00	-\$95,809,035.02
	Capital Total				\$0.00	-\$420,061.31	\$39,659,682.92	-\$39,239,621.61
40	Total				\$0.00	-\$420,061.31	\$39,659,682.92	-\$39,239,621.61
50	School Nutritic	Expense	72	Nutrition Services	\$22,583,377.00	\$14,427,958.24	\$0.00	\$8,155,418.76
			81	Payments to Other Governmental Units	\$1,027,946.00	\$0.00	\$0.00	\$1,027,946.00
		Expense Total			\$23,611,323.00	\$14,427,958.24	\$0.00	\$9,183,364.76
		Revenue	33	Other State Allocations for Current Operations	-\$14,145,547.00	-\$7,144,569.46	\$0.00	-\$7,000,977.54
			44	Local Sources - Unrestricted	-\$9,465,776.00	-\$4,603,612.02	\$0.00	-\$4,862,163.98
		Revenue Total			-\$23,611,323.00	-\$11,748,181.48	\$0.00	-\$11,863,141.52
		School Nutrition Total			\$0.00	\$2,679,776.76	\$0.00	-\$2,679,776.76
50	Total				\$0.00	\$2,679,776.76	\$0.00	-\$2,679,776.76
57	After School	Expense	71	Community Services	\$3,550,225.00	\$1,942,341.44	\$38,246.73	\$1,569,636.83
			81	Payments to Other Governmental Units	\$150,000.00	\$0.00	\$0.00	\$150,000.00
		Expense Total			\$3,700,225.00	\$1,942,341.44	\$38,246.73	\$1,719,636.83
		Revenue	33	Other State Allocations for Current Operations	-\$3,000.00	\$0.00	\$0.00	-\$3,000.00
			44	Local Sources - Unrestricted	-\$3,697,225.00	-\$2,044,387.79	\$0.00	-\$1,652,837.21
		Revenue Total			-\$3,700,225.00	-\$2,044,387.79	\$0.00	-\$1,655,837.21
		After School Total			\$0.00	-\$102,046.35	\$38,246.73	\$63,799.62
57	Total				\$0.00	-\$102,046.35	\$38,246.73	\$63,799.62
80	Other Special	Expense	51	Regular Instructions Services	\$3,991,655.72	\$1,183,868.19	\$91,910.98	\$2,715,876.55
			52	Special Populations Services	\$2,932,863.71	\$1,963,663.07	\$237,830.42	\$731,370.22
			53	Alternative Programs and Services	\$1,370,368.49	\$932,483.29	\$8,064.89	\$429,820.31
			54	School Leadership Services	\$0.00	\$0.00	\$0.00	\$0.00
			55	Co-Curricular Services	\$67,235.07	\$22,298.66	\$5,773.46	\$39,162.95
			58	School-Based Support Services	\$1,182,782.85	\$689,659.41	\$85,393.48	\$407,729.96
			61	Support and Development Services	\$6,078.91	\$1,052.18	\$613.81	\$4,412.92
			62	Special Population Support and Development Services	\$4,000.00	\$2,658.58	\$0.00	\$1,341.42
			63	Alternative Programs and Services Support and Development Services	\$0.00	\$0.00	\$0.00	\$0.00
			64	Technology Support Services	\$165,000.00	\$16,668.72	\$68,331.71	\$79,999.57
			65	Operational Support Services	\$726,657.78	\$77,685.68	\$27,787.54	\$621,184.56
			66	Financial and Human Resource Services	\$18,450.00	\$670.76	\$9,337.39	\$8,441.85
			67	Accountability Services	\$9,066.81	\$0.00	\$0.00	\$9,066.81
			68	System-Wide Pupil Support Services	\$0.00	\$0.00	\$0.00	\$0.00
			69	Policy, Leadership and Public Relations Services	\$250.00	\$250.00	\$250.00	-\$250.00
			71	Community Services	\$161,265.14	\$102,274.40	\$1,942.03	\$57,048.71
			72	Nutrition Services	\$0.00	\$2,401.80	\$0.00	-\$2,401.80
			81	Payments to Other Governmental Units	\$29,593.02	\$0.00	\$0.00	\$29,593.02
			82	Unbudgeted Funds	\$0.00	\$0.00	\$0.00	\$0.00
			86	Educational Foundations	\$35,675.00	\$35,675.00	\$0.00	\$0.00
			87	Scholarships	\$96,707.89	\$401.20	\$0.00	\$96,306.69
			84	Unbudgeted Funds	\$0.00	\$0.00	\$0.00	\$0.00
		Expense Total			\$10,797,650.39	\$5,031,710.94	\$537,235.71	\$5,228,703.74
		Revenue	33	Other State Allocations for Current Operations	-\$2,415,626.01	-\$1,544,174.91	\$0.00	-\$871,451.10
			44	Local Sources - Unrestricted	-\$8,382,024.38	-\$3,028,682.04	\$0.00	-\$5,353,342.34
		Revenue Total			-\$10,797,650.39	-\$4,572,856.95	\$0.00	-\$6,224,793.44
		Other Special Total			\$0.00	\$458,853.99	\$537,235.71	-\$996,089.70
80	Total				\$0.00	\$458,853.99	\$537,235.71	-\$996,089.70
	Grand Total				\$0.00	\$6,319,672.30	\$49,736,961.69	-\$56,056,633.99

**Capital Projects
March 2026**

Description	Project Type	Revised Budget	Actuals	Encumbrances	Act/Enc/Req	AvailableBudget
BOND UNALLOCATED SALES TAX	BOND	\$14,247.00	\$0.00	\$0.00	\$0.00	\$14,247.00
EAST ELEMENTARY - NEW SCHOOL	BOND	\$44,092,589.00	\$43,745,976.56	\$14,984.89	\$43,760,961.45	\$331,627.55
EAST UNION MIDDLE PHASE II	BOND	\$28,430,000.00	\$2,840,861.05	\$24,919,098.95	\$27,759,960.00	\$670,040.00
FOREST HILLS HIGH - NEW SCHOOL	BOND	\$104,939,411.00	\$91,728,080.67	\$2,402,478.80	\$94,130,559.47	\$10,808,851.53
PWHS BOND PROJECT - NEW SCH	BOND	\$10,995,000.00	\$46,900.00	\$34,000.00	\$80,900.00	\$10,914,100.00
SUN VALLEY HIGH SCHOOL BOND	BOND	\$8,431,976.47	\$8,431,976.47	\$0.00	\$8,431,976.47	\$0.00
TRANSPORTATION CTR BOND	BOND	\$1,831,049.34	\$1,831,049.34	\$0.00	\$1,831,049.34	\$0.00
WESTERN UNION ELEM BOND	BOND	\$105,500.50	\$105,500.50	\$0.00	\$105,500.50	\$0.00
FY23 BAND UNIFORMS & EQUIP		\$50,000.00	\$49,623.97	\$0.00	\$49,623.97	\$376.03
FY23 BUILDING SYSTEMS		\$8,639,286.00	\$8,318,937.12	\$125,317.58	\$8,444,254.70	\$195,031.30
FY23 EXPANSIONS & RENOV		\$5,833,103.00	\$5,762,497.90	\$62,102.50	\$5,824,600.40	\$8,502.60
FY23 FURNITURE & EQUIPMENT	CIP	\$275,000.00	\$275,000.00	\$0.00	\$275,000.00	\$0.00
FY23 PAINTING	CIP	\$714,000.00	\$714,000.00	\$0.00	\$714,000.00	\$0.00
FY23 ROOFING	CIP	\$1,870,000.00	\$1,870,000.00	\$0.00	\$0.00	\$0.00
FY23 VEHICLES & EQUIPMENT	CIP	\$461,031.00	\$461,031.00	\$0.00	\$461,031.00	\$0.00
FY24 ADA PROJECTS	CIP	\$144,900.10	\$143,985.98	\$0.00	\$143,985.98	\$914.12
FY24 BAND UNIFORMS & EQUIP	CIP	\$50,000.00	\$49,816.20	\$0.00	\$49,816.20	\$183.80
FY24 BUILDING SYSTEMS	CIP	\$8,598,550.00	\$5,616,504.77	\$916,128.23	\$6,532,633.00	\$2,065,917.00
EAST UNION MIDDLE DESIGN	CIP	\$2,721,015.00	\$1,427,294.59	\$459,172.73	\$1,886,467.32	\$834,547.68
FY24 EXPANSION & RENOVATIONS	CIP	\$4,719,548.00	\$3,032,399.35	\$1,168,690.26	\$4,201,089.61	\$518,458.39
FY24 FURNITURE & EQUIPMENT	CIP	\$120,750.00	\$66,388.46	\$53,057.03	\$119,445.49	\$1,304.51
MARVIN RIDGE HIGH HVAC CONTROLS	CIP	\$1,129,013.00	\$383,019.50	\$24,088.13	\$407,107.63	\$721,905.37
FY24 PAINTING	CIP	\$1,298,325.00	\$1,072,954.51	\$19,827.75	\$1,092,782.26	\$205,542.74
FY24 ROOFING	CIP	\$2,307,946.00	\$1,269,857.81	\$72,250.00	\$1,342,107.81	\$965,838.19
FY24 SAFETY & SECURITY	CIP	\$505,943.00	\$397,604.05	\$31,201.16	\$428,805.21	\$77,137.79
FY24 TRANSPORTATION VEH & EQUIP	CIP	\$421,000.00	\$421,000.00	\$0.00	\$421,000.00	\$0.00
FY24 VEHICLES & EQUIPMENT	CIP	\$970,043.00	\$959,677.52	\$10,144.66	\$969,822.18	\$220.82
FY25 BAND UNIFORMS & EQUIP	CIP	\$50,000.00	\$49,998.03	\$0.00	\$49,998.03	\$1.97
FY25 BUILDING SYSTEMS	CIP	\$3,332,600.00	\$1,636,168.14	\$448,871.89	\$2,085,040.03	\$1,247,559.97
FY25 EXPANSION & RENOVATIONS	CIP	\$4,469,410.00	\$2,904,844.37	\$67,254.01	\$2,972,098.38	\$1,497,311.62
FY25 FURNITURE & EQUIPMENT	CIP	\$2,500,000.00	\$788,739.32	\$398,773.24	\$1,187,512.56	\$1,312,487.44
MARVIN RIDGE HIGH CHILLERS	CIP	\$2,640,000.00	\$1,935,006.63	\$25,560.64	\$1,960,567.27	\$679,432.73
FY25 SAFETY & SECURITY	CIP	\$468,600.00	\$395,889.42	\$0.00	\$395,889.42	\$72,710.58
FY25 VEHICLES & EQUIPMENT	CIP	\$3,020,425.00	\$3,003,298.51	\$3,179.34	\$3,006,477.85	\$13,947.15
FY26 VEHICLES & EQUIPMENT	CIP	\$783,000.00	\$642,406.68	\$25,620.00	\$668,026.68	\$114,973.32
LAPTOP LEASES	CIP	\$17,654,112.75	\$15,293,886.05	\$4,009,047.48	\$19,302,933.53	(\$1,648,820.78)
FY26 BAND	CIP	\$50,000.00	\$0.00	\$49,999.98	\$49,999.98	\$0.02
FY26 SCH NUTRITION	CIP	\$250,000.00	\$0.00	\$0.00	\$0.00	\$250,000.00
FY26 SPEC PROJ/ALT FUNDING	CIP	\$607,000.00	\$0.00	\$28,400.00	\$28,400.00	\$578,600.00
FY26 BUILDING SYSTEMS	CIP	\$7,390,375.00	\$2,065.06	\$860,178.61	\$862,243.67	\$6,528,131.33
FY26 EXPANSIONS & RENOV	CIP	\$1,577,000.00	\$0.00	\$17,738.65	\$17,738.65	\$1,559,261.35
FY26 CAPITAL VEH.EQU	CIP	\$783,000.00	642,406.68	25,620.00	\$668,026.68	\$114,973.32
FY26 TRANS VEH.EQ	CIP	\$560,000.00	\$554,148.73	\$0.00	\$554,148.73	\$5,851.27
FY26 PAINTING	CIP	\$1,298,838.00	\$0.00	\$63,800.00	\$63,800.00	\$1,235,038.00
FY26 ROOFING	CIP	\$3,500,000.00	\$0.00	\$0.00	\$0.00	\$3,500,000.00
FY26 SAFETY & SECURITY	CIP	\$294,063.00	\$42,733.40	\$130,279.28	\$173,012.68	\$121,050.32
STATE CAPITAL IMPROVEMENT FUNDS		\$1,811,789.30	\$1,811,043.62	\$0.00	\$1,811,043.62	\$745.68
STATE CAPITAL IMPROVEMENT FUNDS		\$8,000,000.00	\$0.00	\$35,923.75	\$35,923.75	\$7,964,076.25

PURPOSE / FUNCTION	OBJECT CODE	DESCRIPTION	SCHOOL		EXPENSE		GRANT		NUTRITION PROGRAM		REVENUE		GRAND	
			FUND	FUND	FUND	FUND	FUND	FUND	FUND	FUND	FUND	FUND	TOTAL	TOTAL
6900	111 SUPERINTENDENT		1	1									1	1
		Policy, Leadership and Public Relations Services		1										1
	113 DIRECTOR/SUPERVISOR		3	21									24	24
5500		Co-Curricular Services		2										2
6100		Support and Development Services		8										8
6100		Support and Development Services		1										1
6200		Special Population Support and Development Services	1	2										3
6300		Alternative Programs and Services Support and Development Services		1										1
6400		Technology Support Services		2										2
6500		Operational Support Services	1											1
6500		Operational Support Services		1										1
6600		Financial and Human Resource Services		1										1
6800		System-Wide Pupil Support Services		1										1
6900		Policy, Leadership and Public Relations Services		2										2
7200		Nutrition Services	1											1
	114 PRINCIPAL		51	2									53	53
5400		School Leadership Services	51	2										53
	115 FINANCE OFFICER		1										1	1
6600		Financial and Human Resource Services	1											1
	116 ASSISTANT PRINCIPAL(NON TEACH)		46	47									93	93
5400		School Leadership Services	46	47										93
	117 ASSISTANT PRINCIPAL-OTH ASSIGN		3	4									7	7
5400		School Leadership Services	3	4										7
	118 ASSISTANT SUPERINTENDENT		2	3									5	5
6600		Financial and Human Resource Services	2	3										5
6900		Policy, Leadership and Public Relations Services	2	2										4
	121 TEACHER		2204	19								8	2304	2304
5100		Regular Instructions Services	1428	18										1451
5100		Regular Instructions Services		1										1
5100		Regular Instructions Services	167											167
5100		Regular Instructions Services	13											13
5100		Regular Instructions Services	125											125
5100		Regular Instructions Services	119											119
5100		Regular Instructions Services	57											57
5200		Special Populations Services	165					42				2		209
5200		Special Populations Services	21					3						24
5200		Special Populations Services	47											47
5200		Special Populations Services	46											46
5300		Alternative Programs and Services	16											16
5300		Alternative Programs and Services						14						14
5300		Alternative Programs and Services						9						9
														6
														15

122 INTERIM TEACHER							7	7
5100	Regular Instructions Services			7			7	
123 JROTC TEACHER							10	10
5100	Regular Instructions Services			10			10	
124 FOREIGN EXCHANGE (VIF)							116	116
5100	Regular Instructions Services	20					20	
5100	Regular Instructions Services	90					90	
5200	Special Populations Services	5					5	
5200	Special Populations Services	1					1	
127 MASTER TEACHER							11	1
5100	Regular Instructions Services	11		1			12	
131 INSTRUCTIONAL SUPPORT I							192	36
5100	Regular Instructions Services	10				5	7	
5200	Special Populations Services	6	1				7	
5200	Special Populations Services	2				1	3	
5200	Special Populations Services					1	1	
5300	Alternative Programs and Services	4	5		1		10	
5300	Alternative Programs and Services				3		3	
5800	School-Based Support Services	43	5				48	
5800	School-Based Support Services	81	25			1	109	
5800	School-Based Support Services	46				3	49	
132 INSTRUCTIONAL SUPPORT II							41	3
5200	Special Populations Services	40			3		43	
5200	Special Populations Services	1				1	2	
133 PSYCHOLOGIST							16	16
5200	Special Populations Services	16					16	
135 INSTRUCTIONAL FACILITATORS							38	10
5100	Regular Instructions Services	21	10				31	
5100	Regular Instructions Services	4					4	
5200	Special Populations Services	8			2		10	
5200	Special Populations Services	2					2	
5200	Special Populations Services	3					3	
5300	Alternative Programs and Services					4	4	
6100	Support and Development Services					1	1	
142 TEACHER ASSISTANT - NCLB							275	253
5100	Regular Instructions Services	18	239			58	593	
5200	Special Populations Services	221			33		254	
5200	Special Populations Services	26			9		35	
5200	Special Populations Services	2			1		3	
5300	Alternative Programs and Services	6	14				20	
5300	Alternative Programs and Services				8		8	
5300	Alternative Programs and Services				7		14	
5800	School-Based Support Services	2					2	

143 TUTOR							28	67	23	118	
5300	Alternative Programs and Services		28	67	23	118					
144 INTERPRETER, BRAILLIST, TRANSL							6	3	5	14	
5200	Special Populations Services		6			6					
5200	Special Populations Services					2					
5300	Alternative Programs and Services			3		3					
145 THERAPIST							23	5	28		
5800	School-Based Support Services		23	5		28					
146 SPECIALIST (SCHOOL BASED)							32	9	11	54	
5200	Special Populations Services		1		1	1					
5200	Special Populations Services		2			2					
5200	Special Populations Services					1					
5300	Alternative Programs and Services		27	1	4	28					
5300	Alternative Programs and Services				1	4					
5300	Alternative Programs and Services					1					
5800	School-Based Support Services			1		1					
5800	School-Based Support Services				1	1					
5800	School-Based Support Services			6		6					
5800	School-Based Support Services		2	1		3					
5800	School-Based Support Services				4	4					
147 MONITOR							63	1	64		
5800	School-Based Support Services			1		1					
6500	Operational Support Services		63			63					
151 OFFICE SUPPORT							20	183	3	5	214
5400	School Leadership Services		4	47		51					
5400	School Leadership Services		6	51		57					
5800	School-Based Support Services		9	43		52					
5800	School-Based Support Services			10		10					
6100	Support and Development Services			10		10					
6100	Support and Development Services		1			1					
6200	Special Population Support and Development Services			1	3	4					
6500	Operational Support Services			1		1					
6600	Financial and Human Resource Services			11		11					
6600	Financial and Human Resource Services			1		1					
6800	System-Wide Pupil Support Services			1		1					
6900	Policy, Leadership and Public Relations Services										
6900	Policy, Leadership and Public Relations Services			1		1					
6900	Policy, Leadership and Public Relations Services			5		5					
6900	Policy, Leadership and Public Relations Services			1		1					
7100	Community Services				3	3					
7200	Nutrition Services				5	5					
152 TECHNICIAN							42	42	42		
5800	School-Based Support Services				1	1					

6400	Technology Support Services					41			41
6700	Accountability Services								
	153 ADMINISTRATIVE SPECIALIST	56	2	7	1	66			
5800	School-Based Support Services	12							12
6100	Support and Development Services	5							5
6100	Support and Development Services	1							1
6300	Alternative Programs and Services Support and Development Services		2						2
6500	Operational Support Services	1							1
6600	Financial and Human Resource Services	11							11
6600	Financial and Human Resource Services	2							2
6600	Financial and Human Resource Services	1							1
6600	Financial and Human Resource Services	12							12
6600	Financial and Human Resource Services	1							1
6700	Accountability Services	1							1
6800	System-Wide Pupil Support Services	5							5
6900	Policy, Leadership and Public Relations Services	1							1
6900	Policy, Leadership and Public Relations Services	3							3
7100	Community Services				1				1
7200	Nutrition Services			7					7
	171 DRIVER	236	5			241			
6500	Operational Support Services	236							241
	173 CUSTODIAN	246				246			
6500	Operational Support Services	246							246
	174 CAFETERIA WORKER						192		192
7200	Nutrition Services						192		192
	175 SKILLED TRADES	42	130	1	1	174			
6500	Operational Support Services	42	20						62
6500	Operational Support Services		110					1	111
7200	Nutrition Services			1					1
	176 MANAGER			50	11	61			
7100	Community Services				11				11
7200	Nutrition Services			50					50
	178 DAY CARE/BEFORE/AFTER SCH CARE				55	55			
7100	Community Services				55				55
	GRAND TOTAL BY FUND	3696	901	184	255	45	70	45	5151

Student Name	KG	1st	2nd	3rd	4th	5th	6th	7th	8th	9th	10th	11th	12th	13th	Total
Antioch Elementary	109	112	123	147	156	148	0	0	0	0	0	0	0	0	795
Benton Heights Elementary School of the Arts	68	69	75	67	70	68	0	0	0	0	0	0	0	0	417
East Elementary	60	67	70	62	69	73	0	0	0	0	0	0	0	0	401
Fairview Elementary School	77	60	53	82	71	63	0	0	0	0	0	0	0	0	406
Hemby Bridge Elementary School	59	63	85	81	76	101	0	0	0	0	0	0	0	0	465
Indian Trail Elementary School	104	88	117	102	100	102	0	0	0	0	0	0	0	0	613
Kensington Elementary School	96	112	115	132	190	184	0	0	0	0	0	0	0	0	829
Marshville Elementary School	63	63	78	60	57	69	0	0	0	0	0	0	0	0	390
Marvin Elementary School	74	79	95	105	132	141	0	0	0	0	0	0	0	0	626
New Salem Elementary School	44	43	43	35	44	47	0	0	0	0	0	0	0	0	256
New Town Elementary	72	96	106	119	113	135	0	0	0	0	0	0	0	0	641
Poplin Elementary School	92	108	128	150	129	124	0	0	0	0	0	0	0	0	731
Porter Ridge Elementary School	104	106	120	113	145	128	0	0	0	0	0	0	0	0	716
Prospect Elementary School	69	76	60	63	56	63	0	0	0	0	0	0	0	0	387
Rea View Elementary	86	93	104	93	121	116	0	0	0	0	0	0	0	0	613
Rock Rest Elementary School	73	46	79	67	71	65	0	0	0	0	0	0	0	0	401
Rocky River Elementary	88	88	87	108	93	98	0	0	0	0	0	0	0	0	562
Sandy Ridge Elementary School	55	55	75	89	98	109	0	0	0	0	0	0	0	0	481
Sardis Elementary School	64	83	84	70	92	68	0	0	0	0	0	0	0	0	461
Shiloh Valley Elementary School	0	0	0	199	193	155	0	0	0	0	0	0	0	0	547
Shiloh Valley Primary School	161	150	188	0	0	0	0	0	0	0	0	0	0	0	499
Stallings Elementary School	125	122	122	138	148	131	0	0	0	0	0	0	0	0	786
Union Elementary School	53	42	51	38	42	60	0	0	0	0	0	0	0	0	286
Unionville Elementary School	95	92	117	112	136	98	0	0	0	0	0	0	0	0	650
Walter Bickett Elementary School	63	74	81	70	88	84	0	0	0	0	0	0	0	0	460
Waxhaw Elementary School	79	93	85	94	106	103	0	0	0	0	0	0	0	0	560
Wedington Elementary School	69	82	110	104	102	143	0	0	0	0	0	0	0	0	610
Wesley Chapel Elementary School	98	95	115	150	128	135	0	0	0	0	0	0	0	0	721
Western Union Elementary School	80	59	83	90	88	96	0	0	0	0	0	0	0	0	496
Wingate Elementary School	74	60	66	63	69	56	0	0	0	0	0	0	0	0	388
Elementary Total	2354	2376	2715	2803	2983	2963	0	0	0	0	0	0	0	0	16194
Cuthbertson Middle School	0	0	0	0	0	0	410	411	441	0	0	0	0	0	1262
East Union Middle School	0	0	0	0	0	0	213	215	245	0	0	0	0	0	673
Health Sciences Academy at Monroe Middle	0	0	0	0	0	0	233	254	282	0	0	0	0	0	769
Marvin Ridge Middle School	0	0	0	0	0	0	397	406	454	0	0	0	0	0	1257
Parkwood Middle School	0	0	0	0	0	0	250	303	285	0	0	0	0	0	838
Piedmont Middle School	0	0	0	0	0	0	307	294	291	0	0	0	0	0	892
Porter Ridge Middle School	0	0	0	0	0	0	488	518	475	0	0	0	0	0	1481
Sun Valley Middle School	0	0	0	0	0	0	326	302	310	0	0	0	0	0	938
Wedington Middle School	0	0	0	0	0	0	433	428	451	0	0	0	0	0	1312
Middle Total	0	0	0	0	0	0	3057	3131	3234	0	0	0	0	0	9422
Central Academy of Technology and Arts	0	0	0	0	0	0	0	0	0	219	227	222	221	0	889
Cuthbertson High School	0	0	0	0	0	0	0	0	0	462	432	428	440	0	1762
Forest Hills High School	0	0	0	0	0	0	0	0	0	258	225	242	142	0	867
Marvin Ridge High School	0	0	0	0	0	0	0	0	0	461	461	502	490	0	1914
Monroe High School	0	0	0	0	0	0	0	0	0	355	323	274	208	0	1160
Parkwood High School	0	0	0	0	0	0	0	0	0	16	277	278	266	210	1047
Piedmont High School	0	0	0	0	0	0	0	0	0	375	284	309	240	0	1208
Porter Ridge High School	0	0	0	0	0	0	0	0	0	508	442	378	403	0	1731
South Providence	0	0	0	0	0	0	9	13	22	31	12	6	1	0	94
Sun Valley High School	0	0	0	0	0	0	0	0	0	290	299	282	321	0	1192
Union County Early College	0	0	0	0	0	0	0	0	0	75	83	73	61	14	306
Wedington High School	0	0	0	0	0	0	0	0	0	474	506	475	420	0	1875
Wolfe School	0	0	0	0	0	0	0	9	7	6	12	7	14	53	108
High Total	0	0	0	0	0	0	18	20	44	3797	3579	3471	3210	14	14153
District Total															39769



Union County, NC

Staff Report

Union County Government
Center
500 North Main Street
Monroe, North Carolina
www.unioncountync.gov

File #: 26-252

Agenda Date: 5/4/2026

TITLE:

Rezoning Petition RZ-2026-004 McAlister

INFORMATION CONTACT:

John Wear, Planning Department, Senior Planner - Current Planning, 704-283-3605

ACTION REQUESTED:

Approve or deny proposed rezoning.

TO **APPROVE** THE PROPOSED AMENDMENT (THE PROPOSAL IS CONSISTENT WITH THE CURRENT PLAN)

Motion

- (i) Adopt the Ordinance Approving Revision to the Official Zoning Map of Union County, North Carolina, and (ii) adopt the consistency and reasonableness statement for approval.

TO **DENY** THE PROPOSED AMENDMENT (THE PROPOSAL IS INCONSISTENT WITH THE CURRENT PLAN)

Motion

- (i) Deny rezoning petition RZ-2026-004 from Tommy McAlister, Jr.; and (ii) adopt the consistency and reasonableness statement for denial.

PRIOR BOARD ACTION:

April 20, 2026, Regular Meeting, Agenda Item #26-203 - Conduct public hearing.

BACKGROUND:

This case is a request to rezone one parcel totaling 10.848 acres appearing on the tax map as tax parcel 04-036-007 located on Pageland Highway from Highway Corridor (HC) with Conditions to Light Industrial (LI). The rezoning request is a straight rezoning, so there are no conditions associated with this request.

The Land Use Board evaluated this proposal at its March 17 meeting and recommended approval on a 7-0 vote, citing consistency with the land use map.

A public hearing was conducted April 20, 2026, and no one spoke for or against the proposed rezoning.

FINANCIAL IMPACT:

None.

Application for Straight Rezoning

Union County
Planning Department
500 N Main Street - Suite 70
Monroe, NC 28112
T 704.283.3565
E UCPlanning@unioncountync.gov

General Information

Project Address 4308 Pageland Hwy City MONROE State NC Zip 28112
Tax Parcel ID 04-036-007 Current Zoning Designation HC CZ Total Acres 10.848
Proposed Zoning Designation LI Date Submitted 2-13-2026

Project Description or Intent of Rezoning

CHANGE ZONING from Highway Commercial w/ special conditions to Light Industrial with no conditions.

Contact Information

Applicant Name Tommy McAlister Jr
Address 5234 Leonard Morgan Rd City Marshville State NC Zip 28103
Phone 704-363-7230 Fax - Email [REDACTED]

Property Owner Name

Winding Creek LLC
Address 5234 Leonard Morgan Rd City Marshville State NC Zip 28103
Phone 704-363-7230 Fax - Email [REDACTED]

Applicant's Certification

Signature [Signature] Date 2/11/2026 Printed Name/Title Tommy McAlister Jr Member

Owner's Certification (include names and signatures of all owners)

Signature Kim C. McAlister Date 2/11/2026 Printed Name/Title Kim C. McAlister Member

Union County Office Use Only:

Case Number: 2026-RZ-004 Date Received: 2-13-26

Amount of Fee (\$600): BEA Fee Ok: BEA Received by: BEA

Contact: Bjorn Hansen T. 704.283.3690 E. Bjorn.Hansen@unioncountync.gov



To: Union County Planning

Bjorn Hansen

From: Winding Creek, LLC

Tommy McAlister, Jr.

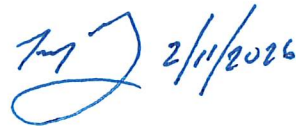

RE: 4308 Pageland Hwy. Monroe, NC 28112

Rezoning to LI

Thank you for the opportunity to submit this request. Whitley Power Equipment, Inc. is no longer doing retail business at 4308 Pageland Hwy.; therefore, we would like to change zoning to Light Industrial, from the existing Highway Commercial with special uses. Also, we would like to remove the special use designation to better align with the surrounding area (601 corridor). The original building was built in the 1960's and early 1970's. Hwy 601 widening project was completed in 2010 before we purchased the property in 2012. There were no setback issues since the building was built prior to the Hwy 601-widening project. Thank you for your attention to this request.

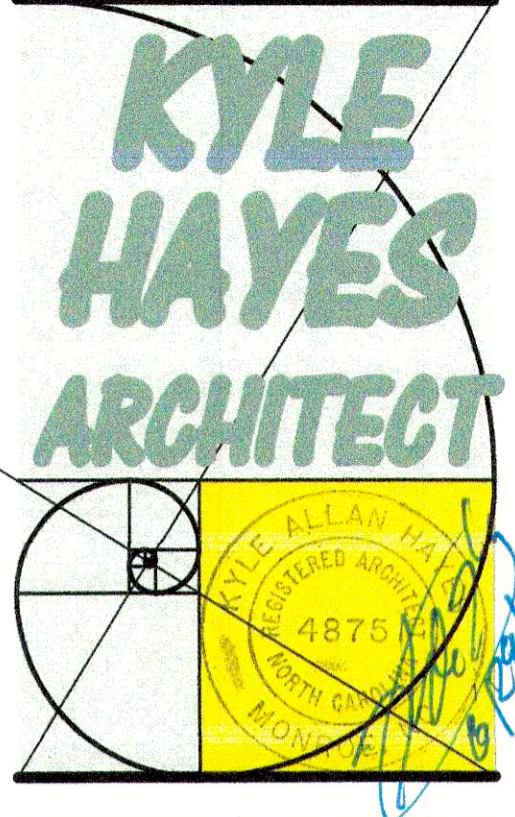

PROJECT
Equipment Shed

address
4308 pageland hwy
Monroe NC 28112

OWNER
Whitly Power
Equipment Inc.

site plan

REVISIONS:
12.31.15 revised sidewalk and parking layout

KYLE HAYES, ARCHITECT
217 N. HAYNE ST.
MONROE, NC 28112

704.226.0600 office
704.533.2287 cell

kyle@perigee.net

DATE: JUNE 29, 2015

THESE DRAWINGS ARE PROTECTED BY FEDERAL COPYRIGHT LAWS AND MAY NOT BE USED OR COPIED IN WHOLE OR PART WITHOUT THE ARCHITECT'S WRITTEN PERMISSION

SHEET

C1 OF 1
job-~~PRE-12-name-DATE~~

VICINITY MAP

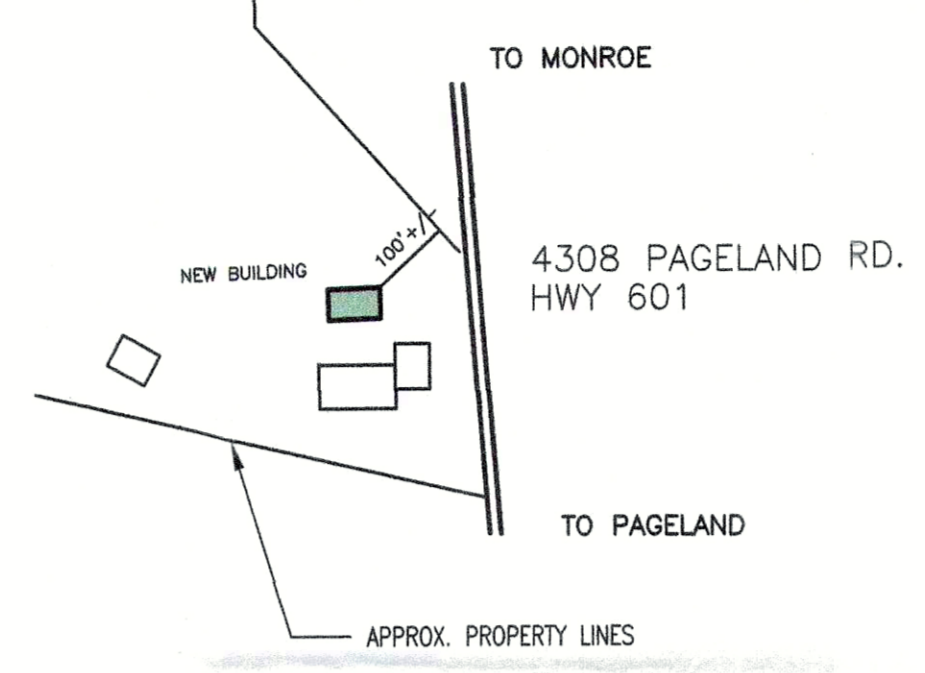

DEVELOPMENT SUMMARY
WHITLEY POWER EQUIPMENT INC.
4308 PAGELAND HWY.
MONROE, NC 28112

EXISTING BUILDINGS BUILT 1974
BUILDING 1 8,400sq.ft.
BUILDING 2 4,860sq.ft.

NEW BUILDING 2,653sq.ft.
DISTURBED AREA <5,000sq.ft.

ALL SITE INFORMATION TAKEN FROM SURVEY PREPARED BY JEREMY GILLIARD PLS DATED 12/01/2011. UNION COUNTY GIS MAPPING SYSTEM, AND THE COUNTY ZONING MANUAL.

PROPERTY INFO.
TAX ID 04-036-007
CHADWICK R. WHITLEY & WF JENNIFER G WHITLEY
DB 3317 PG 789

10.464 ACRES

ZONING HC
PARKING REQUIREMENTS
45,030 STORAGE WAREHOUSE
.5 SPACE PER EMPLOYEE
1 SPACE PER 5,000sq.ft. interior space 10 spaces
RETAIL SALES-1 SPACE/400sq.ft. 16 spaces

EXISTING EMPLOYEES 12, NO NEW HIRES
EXISTING AND RELOCATED PARKING 31 SPACES PROVIDED
REQUIRED PARKING 26 SPACES REQUIRED

SCREENING LI-R40
S2 SCREEN REQUIRED
NEW CONSTRUCTION IS SCREENED FROM ADJACENT R40 PROPERTY BY EXISTING DEVELOPMENT. NO NEW SCREENING REQUIRED. EXISTING TREE LINE ADJACENT TO R40 PROPERTY

SETBACKS
50' FRONT YARD
20' SIDE YARD
50' REAR YARD

PROPERTY IS NOT IN A FLOOD PLANE
NO EXTERIOR LIGHTING IS BEING ADDED

REVISED REEQUIREMENTS 12/28/15
NEW WALK TO ACCESSIBLE TOILETS.
CHANGE IN ELEVATION 37"
37"x20"/INCH OF ELEVATION=740"/12=61'8" OF WALK WAY.
MAX SLOPE IS 6" IN 10' (1.5" IN 30")
WALK WAY IS LESS THAN 1:20, IS NOT CLASSIFIED AS A RAMP.
NO HANDRAILS REQUIRED. WALK IS 48" WIDE. SLOPE IS ADEQUATE TO DRAIN WALK AREA. (NO COVER REQUIRED)

NEW ACCESSIBLE PARKING
NEW ACCESSIBLE PARKING TO BE PAVED.
PAVED AREA TO HAVE NO GREATER FALL THAN 1:48 (1/4 PER FT.)
4.5" MAX SLOPE PER 18" OF PARKING AREA.
ACCESSIBLE PARKING SPACE AND ACCESS AREA TO BE 18' WIDE x19' DEEP
PAVED ACCESS AREA SHALL CONNECT TO EXISTING CONCRETE SIDEWALK.
ANY CONNECTING WALK CAN BE UP TO .6" SLOPE PER FOOT.

NEW PARKING AREA FOR NEW STRUCTURE.
NEW GRAVELED PARKING AREA TO REPLACE EXISTING GRAVELED PARKING AREA ON BACK SIDE OF LOT. EXISTING GRAVEL AREA MATCHING AREA OF NEW GRAVEL PARKING SHALL HAVE GRAVEL REMOVED AND PLANTED BACK IN GRASS.
NEW PARKING REQUIRED FOR MERCANTILE USE 10 SPACES INCLUDING ONE ACCESSIBLE SPACE

REQUIRED TOILET FACILITIES
CURRENT FIXTURE COUNT
3 TOILETS
3 HAND SINKS
TOTAL REQUIRED (measured from inside wall face)
STRUCTURES SEPARATED BY MORE THAN 10' REQUIRED NO FIRE RATINGS. PER TABLE 502.
TOTAL BUILDING 1 AREA WITH TOTAL ALLOWABLE AREA OF 9,000sq.ft.+4,500sq.ft.(frontage increase)=13,500 TOTAL ALLOWABLE AREA EXISTING BUILDING AND NEW STRUCTURE=11,239sq.ft.

EXISTING BUILDING 1	8,640sq.ft.
EXISTING OUT BUILDING 2	4,674sq.ft.
NEW STRUCTURE (includes porch)	2,599sq.ft.
TOTAL MERCANTILE AREA	6,195sq.ft./1/30=207 people
TOTAL STORAGE AREA	9,718sq.ft./1/300=33 people
MERCANTILE REQUIREMENTS	1 TOILET/500 PEOPLE
STORAGE REQUIREMENTS	1 TOILET/100 PEOPLE
REQUIRED TOILETS	2, 1 MEN'S, 1 WOMEN'S
PROVIDED TOILETS	3, 2 IN RETAIL AREA, 1 IN SHOP AREA

EXISTING TOILET FACILITIES ARE MORE THAN ADEQUATE TO MEET PLUMBING REQUIREMENTS

#04-063-013B
EARL WAYNE RAPE
DB 734 PG 163
ZONING LI

#04-063-007A
EARL RAPE & EARL WAYNE RAPE
DB 3963 PG 592
ZONING LI

#04-036-032
EARL RAPE & EARL WAYNE RAPE
DB 3735 PG 426
ZONING LI

#04-063-013D
EARL WAYNE RAPE
DB 1012 PG 149
ZONING R40

#04-036-004
FRANKLIN W. HOWEY, JR.
DB 835 PG 900
ZONING R-40

1 SITE PLAN
1" = 40'

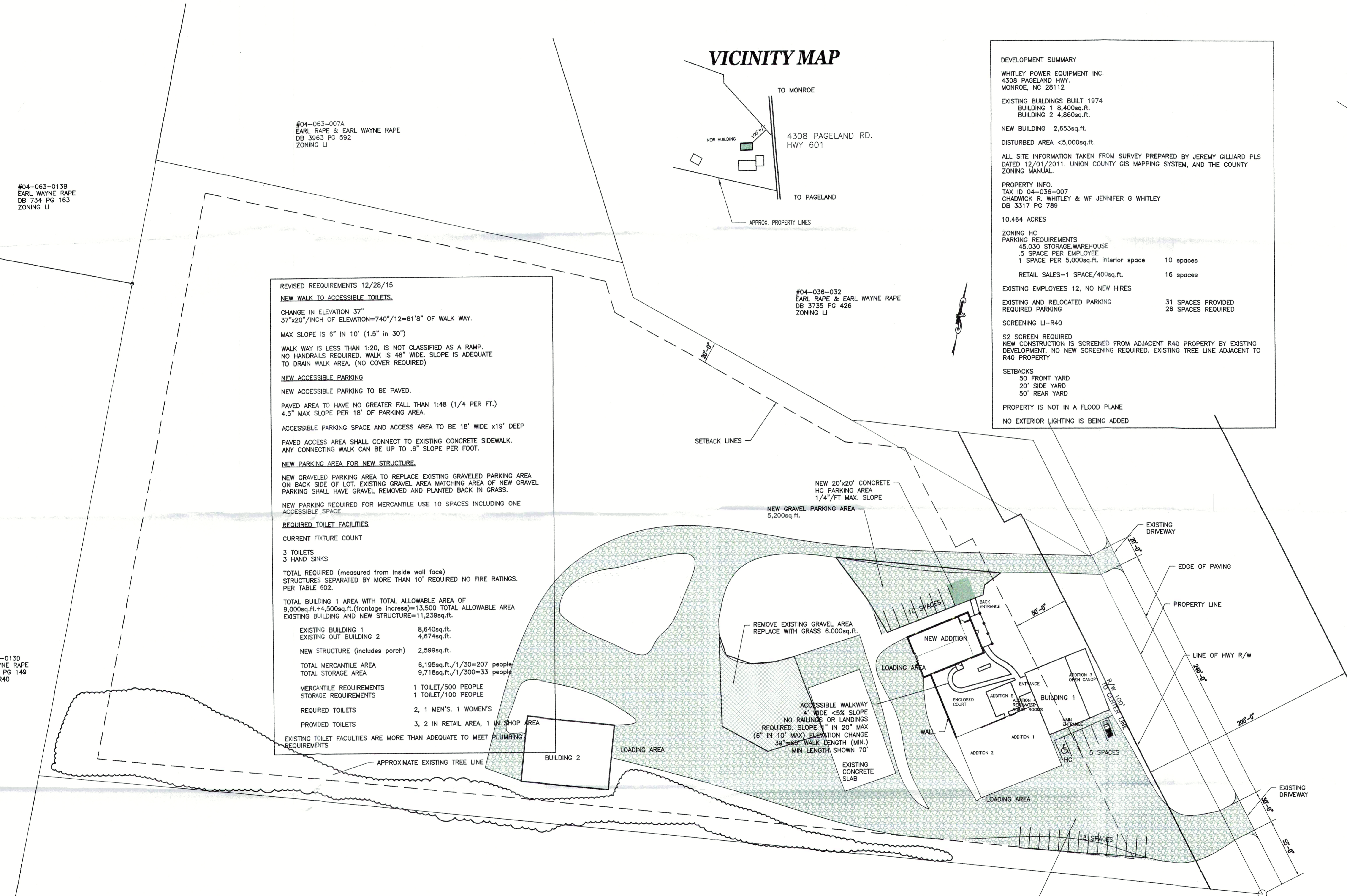

EXISTING GRAVEL PARKING AND DRIVE AREA.
PARKING AREA ACCOMMODATES OVER 30 VEHICLES
ABOUT GRAVELED AREA.

Rezoning Request RZ-2026-004

This case is a request to rezone one parcel totaling 10.848 acres appearing on the tax map as tax parcel 04-036-007 located on Pageland Highway from Highway Corridor (HC) with Conditions to Light Industrial (LI). The rezoning request is a straight rezoning, so there are no conditions associated with this request.

Contact Information

1. Staff: John Wear, Senior Planner, 704-283-3605, john.wear@unioncountync.gov
2. Owner: Winding Creek, LLC, 5226 Leonard Morgan Road, Marshville, NC 28103
3. Applicant: Tommy McAlister, Jr., 5234 Leonard Morgan Road, Marshville, NC 28103

Property Information

Located on the west side of Pageland Highway south of Claude Austin Road. Location more specifically described as tax parcel 04-036-007.



Site



North of Site



South of Site



Opposite Site

Municipal Proximity

The site is approximately three miles south of the City of Monroe.

Existing Land Use and Development Status

The parcel is currently zoned Highway Corridor (HC) with Conditions and currently is used for office and contractor equipment storage. The property was rezoned in 2016, with the following restrictions: off-premise signs, campground/RV park, flea market, or Type 3 mini-storage.

Development Status

Petition: 2026-RZ-004
 Name: McAlister

Size: 10.848 acres
 Tax Parcel: 04-036-007

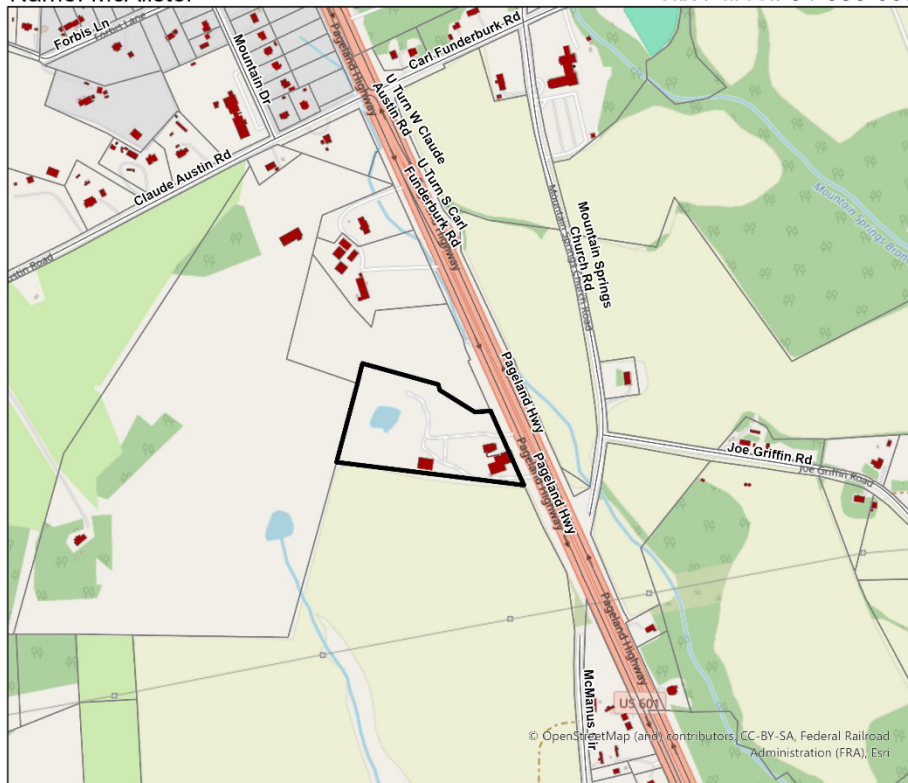

Legend

- Rezoning Parcel
- Parcels
- Roads
- 2023 Structures

Data Disclaimer
 The purpose of the Union County GIS Department includes maintaining geographical information about Union County in electronic format. Please note that inadvertent errors can occur, and information provided by the Department is not intended to replace any official source of information such as recorded deeds, plats, and other public records and data. This information is presented "as is" and without warranties, either express or implied. Users are advised that their use of any County data is at their own risk. The user agrees that Union County shall be held harmless from all actions, claims, damages or judgments arising out of the use of data obtained from the Union County GIS Department. Certain data provided by this Department is maintained by third parties over whom Union County has no control. As such, Union County makes no representation as to the accuracy, appropriateness or any other aspect of information provided by this Department.

Map Disclaimer
 This map is prepared for the representation of property found within Union County, NC and is compiled from recorded deeds, plats, and other public records and data. Users of this map are hereby notified that the aforementioned public primary information sources should be consulted for verification of the information contained on this map. Union County and the mapping companies assume no legal responsibilities for the information contained on this map. Users are advised that their use of this map is at their own risk. The user agrees that Union County shall be held harmless from all actions, claims, damages or judgments arising out of the use of this map. Certain data used to create this map is maintained by third parties over whom Union County has no control, and Union County makes no representation as to the accuracy, appropriateness, or any other aspect of this map.



0 250 500 1,000
 Feet

Created on February 23, 2026 by Bjorn E. Hansen, AICP CTP.
 Contact: (704) 283-3690 or bjorn.hansen@unioncountync.gov



Environmental Features

There are no streams, wetlands or floodplain on site.

Environmental Features

Petition: 2026-RZ-004
Name: McAlister

Size: 10.848 acres
Tax Parcel: 04-036-007



Legend

- Rezoning Parcel
- Parcels
- Roads
- Streams
- Wetlands Areas

Data Disclaimer
The purpose of the Union County GIS Department includes maintaining geographical information about Union County in electronic format. Please note that inadvertent errors can occur, and information provided by this Department is not intended to replace any official source of information such as recorded deeds, plats, and other public records and data. This information is presented "as is" and without warranties, either express or implied. Users are advised that their use of any County data is at their own risk. The user agrees that Union County shall be held harmless from all actions, claims, damages or judgments arising out of the use of data obtained from the Union County GIS Department. Certain data provided by this Department is maintained by third parties over whom Union County has no control. As such, Union County makes no representation as to the accuracy, appropriateness or any other aspect of information provided by this Department.

Map Disclaimer
This map is prepared for the representation of property found within Union County, NC and is compiled from recorded deeds, plats, and other public records and data. Users of this map are hereby notified that the aforementioned public primary information sources should be consulted for verification of the information contained on this map. Union County and the mapping companies assume no legal responsibilities for the information contained on this map. Users are advised that their use of this map is at their own risk. The user agrees that Union County shall be held harmless from all actions, claims, damages or judgments arising out of the use of this map. Certain data used to create this map is maintained by third parties over whom Union County has no control, and Union County makes no representation as to the accuracy, appropriateness, or any other aspect of this map.



0 250 500 1,000 Feet

Created on February 23, 2026 by Bjorn E. Hansen, AICP CTP.
Contact: (704) 283-3690 or bjorn.hansen@unioncountync.gov



Utilities

Public water and sewer are not available to the site.

Zoning and Land Use History

The parcel has been zoned HC with Conditions since 2016 and had been used as a gun shop and most recently an office and equipment storage facility. A telecommunications tower had been located on the site but was removed within the past several years. The properties immediately to the north had been rezoned to Light Industrial and Light Industrial with Conditions in 2024 to adjust property boundaries.

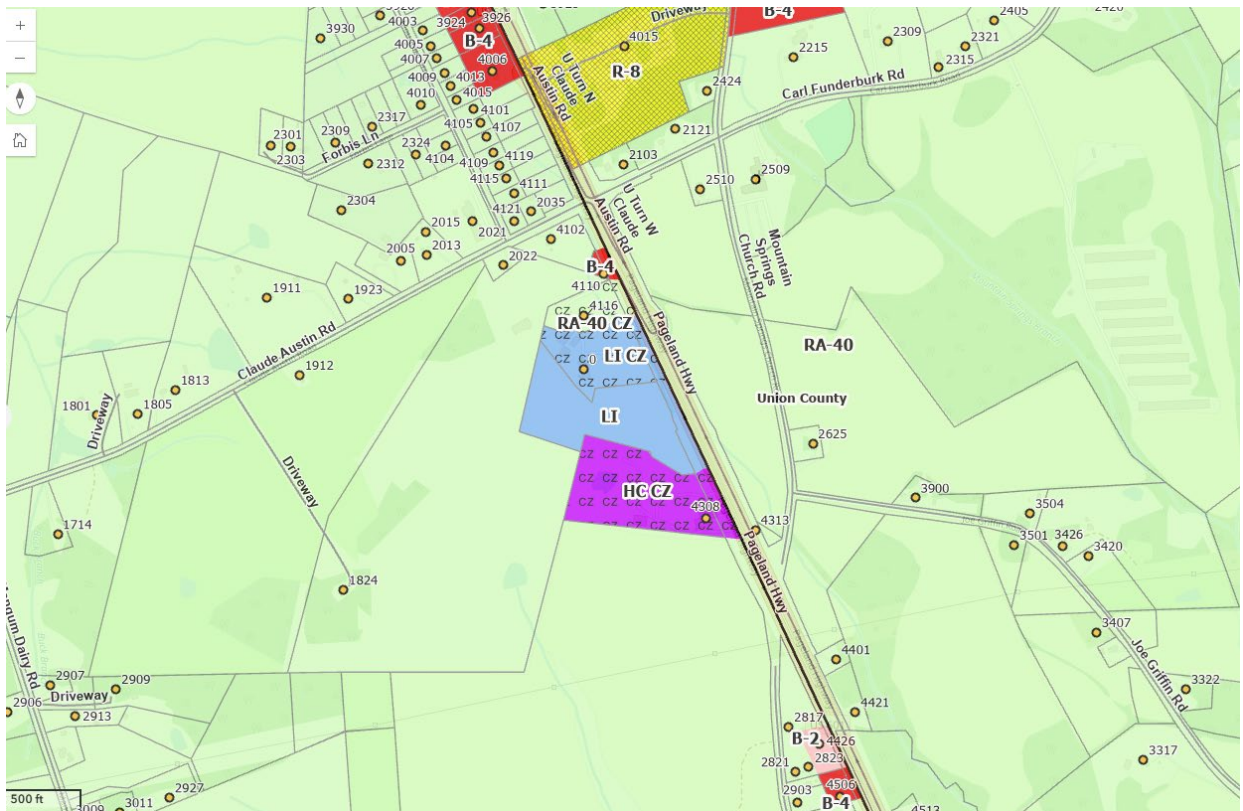

Schools

Because this rezoning request is commercial in nature, UCPS was not consulted for comments.

Transportation

This site is on US 601, which is a NCDOT-maintained facility. This section of US 601 carries approximately 14,000 vehicles per day. There are no funded road improvement projects in the immediate vicinity of the rezoning. A traffic Impact Analysis (TIA) was not required for this rezoning. Because there are no proposed uses with the rezoning, staff are unable to assess impacts on the corridor.

Transportation

Petition: 2026-RZ-004
Name: McAlister

Size: 10.848 acres
Tax Parcel: 04-036-007



Legend

- Rezoning Parcel
- Parcels
- Roads

Data Disclaimer
The purpose of the Union County GIS Department includes maintaining geographical information about Union County in electronic format. Please note that inadvertent errors can occur, and information provided by this Department is not intended to replace any official source of information such as recorded deeds, plats, and other public records and data. This information is presented "as is" and without warranties, either express or implied. Users are advised that their use of any County data is at their own risk. The user agrees that Union County shall be held harmless from all actions, claims, damages or judgments arising out of the use of data obtained from the Union County GIS Department. Certain data provided by this Department is maintained by third parties over whom Union County has no control. As such, Union County makes no representation as to the accuracy, appropriateness or any other aspect of information provided by this Department.

Map Disclaimer
This map is prepared for the representation of property found within Union County, NC and is compiled from recorded deeds, plats, and other public records and data. Users of this map are hereby notified that the aforementioned public primary information sources should be consulted for verification of the information contained on this map. Union County and the mapping companies assume no legal responsibilities for the information contained on this map. Users are advised that their use of this map is at their own risk. The user agrees that Union County shall be held harmless from all actions, claims, damages or judgments arising out of the use of this map. Certain data used to create this map is maintained by third parties over whom Union County has no control, and Union County makes no representation as to the accuracy, appropriateness, or any other aspect of this map.



Created on February 23, 2026 by Bjorn E. Hansen, AICP CTP.
Contact: (704) 283-3690 or bjorn.hansen@unioncountync.gov



Union County Comprehensive Plan

The Union County 2050 comprehensive plan identifies this area as an Employment Corridor overlaid upon Rural Residential. The proposed zoning district is therefore considered appropriate, although a lack of utilities may mean that the site cannot be fully utilized with a significant number of employees or customers.

Land Use Map

Petition: 2026-RZ-004
Name: McAlister

Size: 10.848 acres
Tax Parcel: 04-036-007

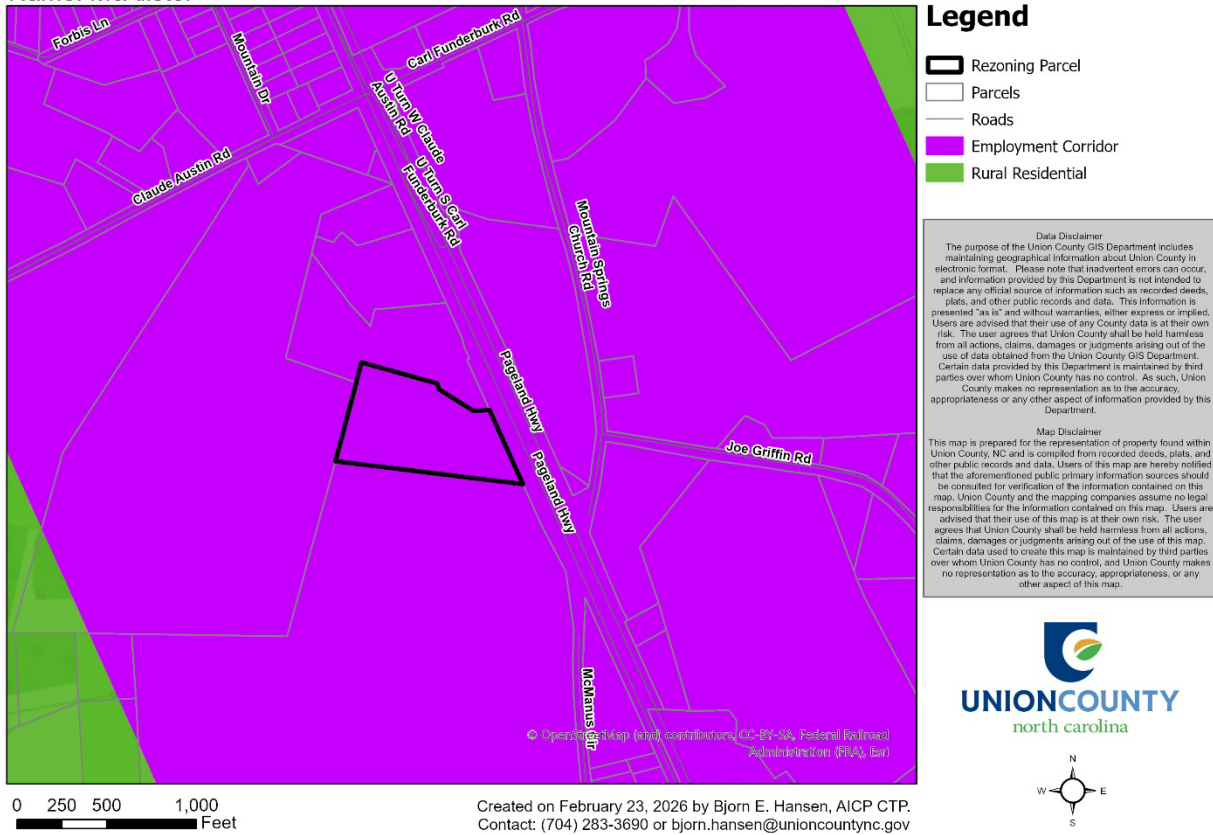

Public and Municipal Comments

Public Comments

A community meeting was not required since this is not a conditional rezoning request.

Municipal Comments

Monroe was not consulted due to the distance to their municipal limits.



Recommendations

Land Use Board

The Land Use Board evaluated this rezoning request at its March 17, 2026, meeting. The Board recommended approval on a 7-0 vote, citing consistency with the land use map.

Planning Department

This part of Union County is identified for employment uses as an overlay over rural residential and agricultural land uses. The proposed zoning is consistent with the adopted Plan because of the appropriate size of the parcel, proximity to adjacent industrial parcels, and previous development history. Because of these aspects of the development, staff recommend **approval** of this rezoning application.



BOCC Motions for Proposed Amendment to the Union County Zoning Map (RZ-2026-004)

The Union County Land Use Board recommended that the Union County Board of Commissioners approve the rezoning petition (RZ-2026-004) submitted by Tommy McAlister, Jr., requesting a revision of the Union County Zoning Map by rezoning one parcel totaling approximately 10.848 acres appearing on the tax map as tax parcel 04-036-007 along US 601 from Highway Corridor with Conditions (HC CZ) to Light Industrial (LI).

TO APPROVE THE PROPOSED AMENDMENT (THE PROPOSAL IS CONSISTENT WITH THE CURRENT PLAN)

Motion

(i) Adopt the Ordinance Approving Revision to the Official Zoning Map of Union County, North Carolina, and (ii) adopt the consistency and reasonableness statement for approval.

TO DENY THE PROPOSED AMENDMENT (THE PROPOSAL IS INCONSISTENT WITH THE CURRENT PLAN)

Motion

(i) Deny rezoning petition RZ-2026-004 from Tommy McAlister, Jr.; and (ii) adopt the consistency and reasonableness statement for denial.

Statements of Consistency and Reasonableness for Proposed Amendment to the Union County Zoning Map

The Union County Land Use Board recommended that the Union County Board of Commissioners approve the rezoning petition (RZ-2026-004) submitted by Tommy McAlister, Jr., requesting a revision of the Union County Zoning Map by rezoning one parcel totaling approximately 10.848 acres appearing on the tax map as tax parcel 04-036-007 along US 601 from Highway Corridor with Conditions (HC CZ) to Light Industrial (LI).

CONSISTENCY AND REASONABLENESS STATEMENT FOR APPROVAL OF THE PROPOSED AMENDMENT (THE PROPOSAL IS CONSISTENT WITH THE CURRENT PLAN) (RZ-2026-004)

Pursuant to N.C.G.S. § 160D-605, the Union County Board of Commissioners (the “Board”) does hereby find and determine that adoption of the proposed map amendment is consistent with the currently adopted Union County Comprehensive Plan (the “Plan”). The adoption of the proposed map amendment (i) takes into account the need to amend the zoning map to meet the needs of the community, and (ii) is reasonable and in the public interest because:

1. The proposed use is consistent with the Plan. The Plan’s Land Use Map identifies this area as Rural Residential with an Employment Corridor overlay. The Plan provides that a variety of employment uses may be appropriate along an Employment Corridor. Development uses that may be appropriate include distribution, logistics, aeronautics, industrial, and agri-business. A rezoning to Light Industrial would allow for many of these development uses contemplated for an Employment Corridor under the Plan.
2. The parcel of land is a larger parcel (over ten acres) and is reasonable in size for the proposed zoning district.
3. An immediately adjacent property is already zoned as Light Industrial, with the subject property also having direct access to US 601. The property is also located within approximately a three-quarter mile radius of an existing commercial use.
4. The benefits to the community at large, the neighbors, and the property owners of the proposed rezoning outweigh any detriments to the neighbors and others caused by the rezoning. The benefits of this rezoning include potentially allowing for increased employment or business uses for the surrounding community to utilize, as well as developing an area designated in the Plan for development along a significant transportation corridor in the County. The potential detriments of the proposed rezoning, depending upon the allowed use utilized in the proposed zoning district, include any increased noise, light, and traffic exposure from the use that could affect nearby properties.

**CONSISTENCY AND REASONABLENESS STATEMENT FOR DENIAL OF THE
PROPOSED AMENDMENT (THE PROPOSAL IS INCONSISTENT WITH THE
CURRENT PLAN) (RZ-2026-004)**

Pursuant to N.C.G.S. § 160D-605, the Union County Board of Commissioners (the “Board”) does hereby find and determine that this rezoning petition is inconsistent with the Union County Comprehensive Plan (the “Plan”) and that denial of the proposed map amendment is reasonable and in the public interest because:

1. Future allowed uses on the property under certain uses allowed in Light Industrial districts could result in increased congestion on the roads and streets adjacent and nearby to the property. Traffic congestion is a noted concern in the Plan.
2. Certain uses allowed in a Light Industrial zoning district are not employment uses that are contemplated uses in an Employment Corridor as identified in the Plan.
3. The proposed rezoning will facilitate ongoing and potential future industrial uses in close proximity to existing residential uses, including residential uses in areas identified as Rural Residential.

ORDINANCE APPROVING REVISION TO THE OFFICIAL ZONING MAP OF UNION COUNTY, NORTH CAROLINA

WHEREAS, the Union County Board of County Commissioners (the “Board”) heretofore enacted the “Unified Development Ordinance of Union County, North Carolina,” including any amendments thereto (the “UDO”) and the official Union County Zoning Map (“Zoning Map”); and

WHEREAS, Union County has received rezoning petition (RZ-2026-004) submitted by Tommy McAlister, Jr., requesting a revision of the Union County Zoning Map by rezoning one parcel totaling approximately 10.848 acres appearing on the tax map as tax parcel 04-036-007 along US 601 from Highway Corridor with Conditions (HC CZ) to Light Industrial (LI) (the “Rezoning Petition”); and

WHEREAS, the Union County Land Use Board considered and made a recommendation concerning approval or denial of the Rezoning Petition; and

WHEREAS, the Board has determined that approval of the Rezoning Petition and rezoning the subject parcel from Highway Corridor with Conditions (HC CZ) to Light Industrial (LI) is reasonable and in the public interest, including for those reasons set forth in the contemporaneously adopted consistency and reasonableness statement.

NOW, THEREFORE, BE IT ORDAINED by the Union County Board of Commissioners as follows:

1. The Zoning Map is hereby amended by rezoning the parcel appearing on the tax map as tax parcel 04-036-007 along US 601 from Highway Corridor with Conditions (HC CZ) to Light Industrial (LI).
2. This ordinance is effective upon adoption.

Adopted this _____ day of _____, 2026.

Brian Helms
Chair, Union County Board of Commissioners



Union County, NC

Staff Report

Union County Government
Center
500 North Main Street
Monroe, North Carolina
www.unioncountync.gov

File #: 26-210

Agenda Date: 5/4/2026

TITLE:

Presentation - Union County Water Capital Program Update

INFORMATION CONTACT:

John Shutak, Union County Water, Engineering Director, 704-283-3651

ACTION REQUESTED:

None.

PRIOR BOARD ACTIONS:

None.

BACKGROUND:

The Capital Improvement Program for Union County Water (UCW), as adopted by the Board of County Commissioners, includes projects related to the expansion of the water and wastewater systems, rehabilitation and replacement of existing infrastructure, as well as buildings and facilities.

UCW staff will provide a presentation on the overall status of the Capital Improvement Program with detailed information on a selection of representative projects.

FINANCIAL IMPACT:

None at this time. Direction received, if any, may impact future expenditures.



Union County, NC

Staff Report

Union County Government
Center
500 North Main Street
Monroe, North Carolina
www.unioncountync.gov

File #: 26-246

Agenda Date: 5/4/2026

TITLE:

FY 2027 Capital Improvement Project Review

INFORMATION CONTACT:

Jason May, Budget & Grant Management, Director, 704-283-3760

ACTION REQUESTED:

Receive information.

PRIOR BOARD ACTIONS:

None.

BACKGROUND:

Staff will present the recommended Capital Improvement Plan (CIP) for Fiscal Year 2027, including proposed projects and funding sources. No action is required; this item is for informational purposes only.

FINANCIAL IMPACT:

None. Proposed CIP will be included in the FY 2027 Budget presentation on June 1, 2026.



Union County, NC

Staff Report

Union County Government
Center
500 North Main Street
Monroe, North Carolina
www.unioncountync.gov

File #: 26-253

Agenda Date: 5/4/2026

TITLE:

FY 2027 Health Plan Changes

INFORMATION CONTACT:

Brian Matthews, County Manager, 704-292-2597

ACTION REQUESTED:

Receive information

PRIOR BOARD ACTIONS:

None

BACKGROUND:

The County Manager will present information to the Board of Commissioners about the upcoming changes to the County's Health Insurance Plan for FY 2027.

FINANCIAL IMPACT:

None



Union County, NC

Staff Report

Union County Government
Center
500 North Main Street
Monroe, North Carolina
www.unioncountync.gov

File #: 26-238

Agenda Date: 5/4/2026

TITLE:

Appointment to the Consolidated Human Services Board

INFORMATION CONTACT:

Janet Payne, Human Services Agency, Executive Director, 704-296-4348; Amy Dickey, Consolidated Human Services Board Chair

ACTION REQUESTED:

Review applications and consider appointing one of the recommended applicants for the vacant Consolidated Human Services Board "Other Person" position.

PRIOR BOARD ACTIONS:

None.

BACKGROUND:

The Consolidated Human Services Board (CHSB), pursuant to N.C. general statute § 153A-77, is permitted to be composed of up to 25 members and composition of the board shall reasonably reflect the population makeup of the County. Currently, the Union County CHSB has 19 membership positions, each of which has a specific designation. Eight positions are filled and there are 11 vacancies including:

- Consumer of Human Services (2)
- Dentist (1)
- Registered Nurse (1)
- Other Person (1)
- Pharmacist (1)
- Physician - Psychiatrist (1)
- Optometrist (1)

As is the County's usual practice, the vacancies available for appointment were advertised by posting a notice on the County's website:

<https://www.unioncountync.gov/government/boards-committees/boardscommittees>

Multiple applications were received to fill the one "Other Person" vacancy and members of the CHSB interviewed the applicants prior to the April 13, 2026 meeting and the CHSB reviewed and discussed all applications at the April 13, 2026 meeting and voted to recommend that the Board of County Commissioners consider the following individuals for appointment to the CHSB to fill the "Other Person" vacancy:

- Mr. Ben Mount is eligible to fill the "Other Person" position.
- Mr. Michael Evola is eligible to fill the "Other Person" position.
- Ms. Linda Yang is eligible to fill the "Other Person" position.

A copy of each individual's application is included for the Board's review and consideration.

FINANCIAL IMPACT:

\$200 per year per member (\$20 meeting x 10 meetings a year).

**APPLICATION TO SERVE ON APPOINTED BOARDS
COMMITTEES OR COMMISSIONS**

BOARD: Consolidated Human Services Board

NAME: Linda Yang

ADDRESS: 2808 Tuscarora Ln Waxhaw NC 28713

TOWNSHIP: Sandy Ridge Township YEARS IN UNION COUNTY 7 years and 9 months

TELEPHONE: (Home) 704-547-4024 (Office) _____ (Fax) _____

E-mail Address: LindaYang-MHA@outlook.com

EDUCATION:

List Schools, dates attended, Degrees obtained

2025: Certified Health Information Officer (CHCIO) and Certified Digital Health Executive (CDH-E)
– College of Health Information Management

2022: Professional Certificate in Data Science and Machine Learning – Massachusetts Institute of
Technology

2023: Qualified Technology Expert (QTE) – Digital Directors Network

2020: Certified Specialist Business Intelligence (CSBI) – Healthcare Financial Management
Association

2012, 2015: Epic Electronic Health Record Certifications – Cogito Analytics, Grand Central and
Prelude, Cadence, Health Information Management, Resolute Hospital Billing, and Resolute
Professional Billing

2011: Master of Healthcare Administration (MHA) concentration in Informatics – University of
Phoenix

2005: Bachelor of Arts in Sociology – North Carolina State University

OCCUPATION:

Past 3 and current employers and positions held

Feb 2024 – Current: Director of Information Strategy and Analytics at Family Health Initiatives

Nov 2023 – Feb 2024: Electronic Health Records Analytics Consultant at People’s Community Clinic

Jan 2023 – Feb 2024: Interim Director of Information Services and Technology at North Carolina Hmong Women Association

Sept 2021 – Sept 2022: Chief Information Officer at Discover Claims

Sept 2020 – Sept 2021: Electronic Health Records Analytics Lead at OrthoCarolina

Sept 2015 – Sept 2020: Analytics Developer at Duke University Health System

Apr 2012 – Sept 2015: Electronic Health Records Developer at Novant Health

Oct 2007 – Apr 2012: Data Consultant at Premier

Please list civic and fraternal organizations in which you participate in Union County.

Current Board Member of Ascend Charlotte Metro

Former Board Member of Society of Information Management Charlotte Metro

Current Community Leader for Carolinas Asian American Chamber of Commerce

Current Volunteer for North Carolina Hmong Women Association

Please explain your interest in serving on the above named board:

I am passionate about advancing initiatives that address social determinants of health, expand access for vulnerable populations, and help guide policy and resource allocation. I am committed to contributing thoughtful, strategic insight to support the Board’s mission and long-term impact. While I am not a licensed provider, I understand there are current vacancies for “Consumer of Human Services” and “Other Person” representatives and would welcome the opportunity to serve in either capacity.

Any other comments:

As someone deeply invested in community health and well-being, I am motivated to contribute to efforts that create more inclusive and accessible systems of care. I would be honored to support the Board's work and help advance initiatives that make a meaningful difference for Union County residents.

Have you ever been convicted of a felony? No

Date: 3/25/2026 Signature: 

Note: Information provided in this application is considered a matter of public record. It is, therefore, subject to disclosure and copying upon request pursuant to North Carolina's Public Records Law, N.C.G.S. §132-1, et seq.

Return to: Lynn G. West, Clerk to the Board, 500 N. Main Street, Room 914, Monroe, NC 28112 or Fax to 704-282-0121 or e-mail to Lynn.West@unioncountync.gov.

FOR OFFICE USE ONLY: Date Received: _____

**APPLICATION TO SERVE ON APPOINTED BOARDS
COMMITTEES OR COMMISSIONS**

BOARD: Consolidated Human Services Board

NAME: Benjamin H. Mount III

ADDRESS: 2302 Old Evergreen Parkway

TOWNSHIP: Indian Trail YEARS IN UNION COUNTY 4

TELEPHONE: (Home) 609-412-4158 (Office) _____ (Fax) _____

E-mail Address: benmount3@gmail.com

EDUCATION:

List Schools, dates attended, Degrees obtained

University of Medicine and Dentistry of New Jersey (UMDNJ), School of Public Health, 2009-2012,
Master of Public Health

University of Pittsburgh, Graduate School of Public and International Affairs, 1980-1982, Master of
Public Administration

Point Park College, School of Journalism and Communications, 1973-1976, Bachelor of Arts degree

OCCUPATION:

Past 3 and current employers and positions held

Currently retired

Atlantic County (NJ) Government, Division of Public Health, Human Services Department, Acting
Division Director and Coordinator of Community Health Services, 2010-2021

Boy Scouts of America, Jersey Shore Council, District Director, 1998-2004

Boy Scouts of America, Southern New Jersey Council, Senior District Executive, 1988-1998

Boy Scouts of America, East Valley Area Council, District Executive/Senior District Executive, 1984-
1988

Senate of Pennsylvania, District Office of Senator Leonard J. Bodack, Administrative Assistant, 1979-
1984

Please list civic and fraternal organizations in which you participate in Union County.

Participant, Indian Trail Citizens Academy

Participant, Union County Sheriff's Office Citizens Academy

Member, Knights of Columbus Council 10582, St. Matthew Church (Ballantyne)

Member, Safety and Security Committee, Heritage South HOA, Indian Trail

Please explain your interest in serving on the above named board:

I am a retired Public Health worker, and I'm looking for an opportunity to use my experience, education and background to assist my community. I have extensive experience in Point of Distribution (POD) Operations, and interfacing between Public Health and state, county and local law enforcement and emergency management (specifically with H1N1 and COVID-19 Pandemic)

I have also worked extensively with volunteers, including recruiting, training, activating and deactivating, and other aspects of volunteer engagement.

Any other comments:

Have you ever been convicted of a felony? **NO**

Date: 3/11/2026 Signature: 

Note: Information provided in this application is considered a matter of public record. It is, therefore, subject to disclosure and copying upon request pursuant to North Carolina's Public Records Law, N.C.G.S. §132-1, et seq.

Return to: Lynn G. West, Clerk to the Board, 500 N. Main Street, Room 914, Monroe, NC 28112 or Fax to 704-282-0121 or e-mail to Lynn.West@unioncountync.gov.

FOR OFFICE USE ONLY: Date Received: _____

**APPLICATION TO SERVE ON APPOINTED BOARDS
COMMITTEES OR COMMISSIONS**

BOARD: Atrium Health Union Advisory Committee or Consolidated Human Services Board (Other Person)

NAME: Michael Tyler Evola

ADDRESS: 247 Marron Drive, Indian Trail, North Carolina 28079-4511

TOWNSHIP: Vance YEARS IN UNION COUNTY 20

TELEPHONE: (Home) 704-219-5797 (Fax) N/A
(Office) _____

E-mail Address: michaelevolanc@gmail.com

EDUCATION:

List Schools, dates attended, Degrees obtained

University of North Carolina at Pembroke
Bachelor of Interdisciplinary Studies - Public and Nonprofit Administration

Central Piedmont Community College
Associate in Applied Science - Accounting & Finance
Certificate - Tax Accounting

Central Academy of Technology & Arts
High School Diploma

OCCUPATION:

Past 3 and current employers and positions held

Community Shelter of Union County
Community Engagement Manager, May 2025 - Present

Union County Department of Social Services
Family & Children's Medicaid Program Eligibility Specialist, May 2023 - May 2025

Town of Indian Trail
Parks and Recreation Assistant, November 2023 - July 2025

Please list civic and fraternal organizations in which you participate in Union County.

North Carolina Council for the Deaf and Hard of Hearing, Governor-appointed Council Member/Chair
North Carolina Statewide Independent Living Council, Governor-appointed Council Member/Chair
Union County Chamber, Member/Chamber Ambassador
Rotary Club of Waxhaw-Weddington, Member

Please explain your interest in serving on the above named board:

My service on state councils has focused on strengthening the quality and efficiency of programs that support individuals with disabilities. In those roles, I have worked to ensure that services are effective, fiscally responsible, and aligned with the real needs of the people they are intended to serve. I hope to bring the same practical, experience-based approach to this board, contributing my professional background and personal perspective as someone living with a disability to help identify common-sense ways to improve accessibility within our community. In my work as part of the staff at the Community Shelter of Union County, I see firsthand how thoughtful policy and strong partnerships can make a meaningful difference for residents facing significant challenges. I would welcome the opportunity to serve on this board to support local solutions, strengthen community collaboration, and help ensure that those with the greatest needs are served in a way that reflects our county's values of transparency, innovation, and being purpose oriented

Any other comments:

Over the years, I've worked for and volunteered with municipal, county, and state government, as well as with many nonprofits throughout our community, serving in roles requiring strategic planning, advisement, community engagement, public policy, and leadership skills.

My LinkedIn profile includes more information about my experience for your consideration: [linkedin.com/in/michaelevolanc](https://www.linkedin.com/in/michaelevolanc).

Have you ever been convicted of a felony? No

Date: 3/9/2026 Signature: 

Note: Information provided in this application is considered a matter of public record. It is, therefore, subject to disclosure and copying upon request pursuant to North Carolina's Public Records Law, N.C.G.S. §132-1, et seq.

Return to: Lynn G. West, Clerk to the Board, 500 N. Main Street, Room 914, Monroe, NC 28112 or Fax to 704-282-0121 or e-mail to Lynn.West@unioncountync.gov.

FOR OFFICE USE ONLY: Date Received: _____

Public servant with experience managing programs, overseeing budgets, organizing volunteers, cultivating partnerships, and engaging communities for nonprofits, local and state government. Proven ability to develop and implement policy and systems for effective service delivery and improvement of organization operations, as well as navigating and ensuring compliance with state and federal regulations. Experienced collaborator with a strong record of leadership in advisory, planning, and implementation roles, with a focus on good governance, public policy, and community impact.

Professional and Leadership Experience

Community Shelter of Union County

Community Engagement Manager | 05/2025 – Present

- Lead community outreach and partnership efforts to increase awareness of shelter services, resources, and policy priorities across Union County.
- Cultivate and manage relationships with community partners to strengthen referral pathways and collaborative initiatives.
- Manage the agency's volunteer program, recruiting, onboarding, training, and supervising volunteers supporting direct services and special projects.
- Implement strategies to expand volunteer participation and improve engagement, supporting organizational capacity and service delivery.

North Carolina Statewide Independent Living Council

Governor-appointed Council Member (Individual with a Disability) | 02/2024 – Present,

Council Chair | 07/2025 – Present, Council Treasurer | 07/2024 – 06/2025

- Lead planning and coordination activities for the Council to advance independent living and priorities aligned with the State Plan for Independent Living.
- Manage budgeting and financial planning for an approximately \$199,000 annual budget, monitoring expenditures, reviewing financial reports, and supporting compliance with federal and state requirements.
- Contribute to governance, performance monitoring, and evaluation activities, supporting accountability, transparency, and effective use of public funds.

North Carolina Council for the Deaf and Hard of Hearing

Governor-appointed Council Member (Hard of Hearing Consumers) | 07/2021 – Present,

Council Chair | 07/2025 – Present, Council Vice Chair | 11/2022 – 06/2025

- Provide leadership, ensuring fulfillment of statutory duties, collaborating with Division leadership, partners, and state agencies to fulfill directives and make recommendations.
- Make recommendations to, partner with and advise, NCDHHS and NCDPI to ensure effective, high-quality, and accessible programs and services.
- Collaborate with state agencies and community stakeholders to support policy implementation, service delivery improvements, and interagency coordination.

Union County Department of Social Services

Family & Children's Medicaid Program Eligibility Specialist | 05/2023 – 05/2025

- Determined initial and ongoing Medicaid eligibility for individuals and families in compliance with state regulations, managing a high-volume caseload.
- Processed applications, recertifications, and case updates while meeting strict accuracy, documentation, and timeliness standards.
- Interpreted complex policy manuals and eligibility criteria, educating applicants on program requirements, participant responsibilities, and available services.
- Conducted needs assessments and coordinated referrals to internal and external support programs, improving continuity of care and access to services.

Mecklenburg County Park and Recreation Department

Recreation Coordinator | 11/2021 – 05/2023

- Coordinated program and event logistics, including scheduling, reservations, permits, invoicing, and contract support.
- Assisted with planning and facilitation of programs and special events, collaborating with internal teams and external groups.
- Maintained accurate records, tracked program participation, and ensured compliance with departmental policies and procedures.

Recreation Assistant | 06/2021 – 11/2021

- Supported operations across multiple facilities, supervising activities, and providing customer service to the public, and enforcing county policies and park rules.
- Provided front-line customer service, educating residents on programs, amenities, policies, and facility rules, and assisting with event setup and program delivery.

Education

University of North Carolina at Pembroke

Bachelor of Interdisciplinary Studies – Public and Nonprofit Administration

Central Piedmont Community College

Associate in Applied Science – Accounting and Finance

Certificate – Tax Accounting

Blue Ridge Community College

Certificate – Fundamentals of American Sign Language

Professional and Leadership Development

North Carolina Center for Nonprofits

Nonprofit Management Institute

North Carolina Department of the Secretary of State

Notary Public Commission | Expires 05/2026

North Carolina Institute of Public Leadership

Fellow

Union County Chamber

Leadership Union

Current Community Engagement, Service, & Leadership

North Carolina Department of Health & Human Services

Human Rights Committee Member | 10/2025-Present

Rotary Club of Waxhaw-Weddington

Club Member | 08/2021-Present

The Grove at Chestnut Park Association

Homeowner Association Board Member | 11/2024-Present

Union County Chamber

Chamber Member | 10/2022-Present

Chamber Ambassador | 01/2025-Present



Union County, NC

Staff Report

Union County Government
Center
500 North Main Street
Monroe, North Carolina
www.unioncountync.gov

File #: 26-245

Agenda Date: 5/4/2026

TITLE:

Appoint Union County Board of Commissioners Representative to Vacant Position on Monroe-Union County Economic Development Commission Board of Directors

INFORMATION CONTACT:

Ron Mahle, Economic Development, Director, 980-476-5279

ACTION REQUESTED:

Appoint Union County Board of Commissioners representative to open position on the Monroe-Union County Economic Development Commission Board of Directors to run through the remainder of the current term, June 30, 2026.

PRIOR BOARD ACTIONS:

None.

BACKGROUND:

As set forth in Section 2(a) of the Interlocal Agreement between Union County and the City of Monroe establishing the Monroe-Union County Economic Development Commission, it is provided that Board members serve one-year terms, commencing on July 1 and running through June 30 of each year. Commissioner Sides was appointed (serving *ex officio*) as a BOCC-appointed EDC Board Member. In the case of a vacancy, the appointing board shall appoint a new member to serve the remainder of the unexpired term.

Due to Commissioner Sides' resignation and unfortunate passing, the Board of County Commissioners is requested to consider appointing a person to fill his position on the EDC Board of Directors.

FINANCIAL IMPACT:

None.